

GRAIN CART BOX DETAIL SHEET

Accurate physical, tape measurements are essential for proper fitting tarp. Complete form along with appropriate section in Systems Guide.

CONTACT INFORMATION

Name _____ Date _____
 Address _____
 City _____ State _____ Zip _____
 Email/Phone _____

BOX MEASUREMENTS Exact Measurements Required

Top Outside Box Length (A) _____
 Top Outside Box Width (B) Front _____ Rear _____
IMPORTANT: For extensions, measure top outside of extensions on angle (tip-top).
 Box Height From Ground (C) _____
 Top Rail Width (D) _____
 Box Extension Kit (10" tall) _____ Box Extension Divider(s) Qty. _____

ROLL TARP SYSTEM

SRT-2 EZ-LOC HD EZ-LOC Side Locking

KIT MATERIAL Galvanized Steel

OPERATION

Manual Return _____ Electric _____

ELECTRIC (see electric conversions section for more information)

Cab Operated Switch Control Control Box and Remote

CONVERSION SRT-2 ECONOMICAL

END CAPS (split over 121" wide)

NOTE: If ordering flat rise or top mount, ensure box is flat across top.
 Order side mount for box with uneven angles across top.

QUANTITY	None	1	Recommended (2)
MATERIAL	<input checked="" type="checkbox"/> Galvanized		
RISE	7"	12"	Flat
DEPTH	14"	10"	
FRONT	Side Mount	Top Mount	
REAR	Side Mount	Top Mount	
BRACKETS	Side	Top Z	Top Bolt Through
	Quick Release		

FILLERS

FRONT	Metal	18 oz.	22 oz.
REAR	Metal	18 oz.	22 oz.
DEPTH		Front (I ¹) _____	Rear (I ²) _____
MOUNT (metal only)		Front Side Top	Rear Side Top
DROP (fabric only)		Front (M) _____	Rear (K) _____

TARP

18 oz. 22 oz.

Tarp Color(s) _____

RIDGE SUPPORT

None Strap Qty. _____ Rope Qty. _____

BOWS (included up to 28')

None Recommended Qty. _____ Custom Qty. _____

MISCELLANEOUS

Spacer Bracket Kit Handle Holder Extension

ADDITIONAL OPTIONS AND ACCESSORIES	QTY.

BOX MEASUREMENTS

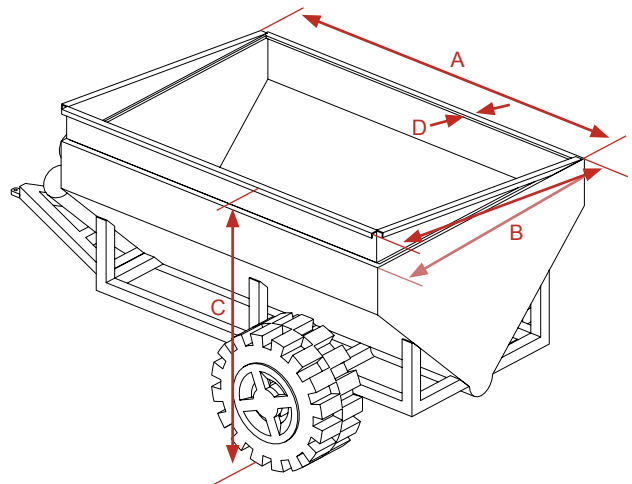

BOX WITH UNEVEN ANGLES

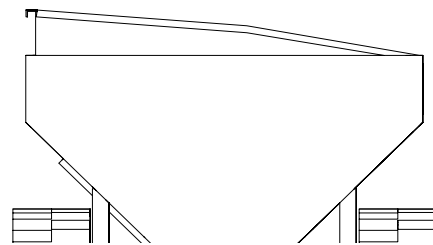

FILLERS

Metal Fabric (18 oz. or 22 oz.)

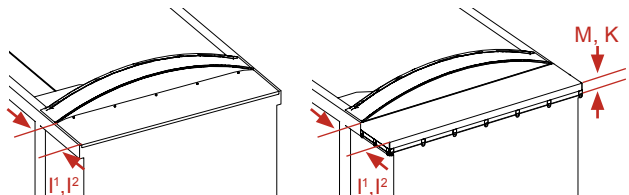

SPACER BRACKET

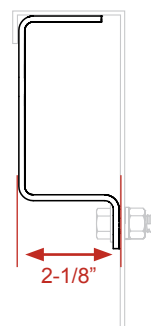

3000 Hwy 281 SE
 Jamestown, ND 58401
 T (800) 233-4655
 F (800) 592-4460
 orderdesk@agricover.com