

TOOLBOX EDITION ROLL UP TRUCK BOX COVER SPECIAL BOLT ON HEADER BAR INSTRUCTIONS

2015-ON FORD F-150

Read and follow these special instructions along with the standard instructions carefully before installing or using this cover.

NOTICE TO INSTALLER: Even if familiar with product, read special instructions prior to installation as improvements may be made without notice. Always handle components with care. When done, these special instructions must be given to the consumer.

NOTICE TO CONSUMER: Before using this product, read special instructions. Save these special instructions for future reference.

PREPARATION

IMPORTANT: Toolbox Cover may impede latch operation on some low profile toolboxes.

TOOLS NEEDED

- (1) 5/16" Hex driver or socket wrench with 5/16" socket
- (1) Drill with 1/8" drill bit
- (1) Protective eyewear
- (1) Marking pen

▲ CAUTION: Over torquing hardware may damage components. Do not use impact tools.

NOTE: Use the following steps instead of Step 1B in the special toolbox instructions if unable to clamp header bar due to truck box structure.

1. INSTALLATION PROCESS

A. Align header bar flush with top of box, push tight against toolbox wall while applying enough pressure to compress weather seal against toolbox wall.

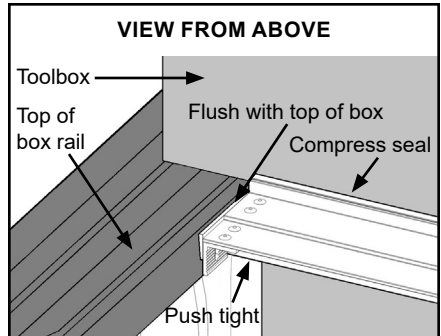

B. Hold or clamp in place and mark box rails at center of holes to allow for adjustment later.

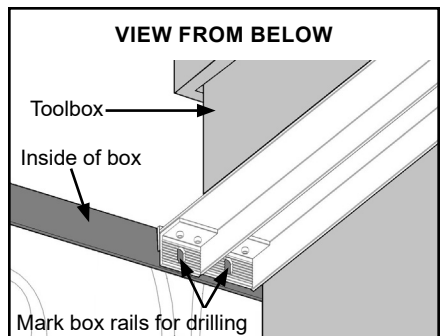

1. INSTALLATION PROCESS (Continued)

C. At marked locations drill 1/8" holes through box rails then attach header bar to box rails with (4) 3/4" self-threading hex head bolts; do not tighten yet.

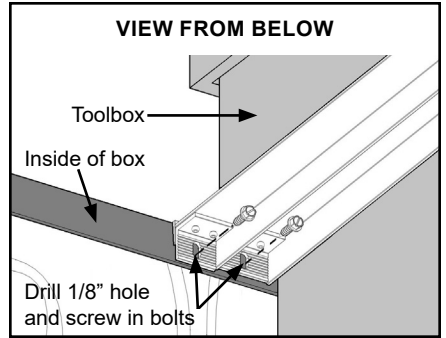

D. Adjust header bar as directed in Step 1A and fully tighten bolts. When header bar installation is complete, proceed to Step 2 of special toolbox instructions.

