

REPLACING AUTOLOCK[®] DRIVE LINE CORD



TOOLS NEEDED:

Lock Pliers, Utility Knife,
Marking Pencil, Electrical
Tape and Protective
Eyewear

PREPARATION: Start by rolling tarp tube down until it hangs loose along side of box (fig. 2). Unplug power to tarp motor. Pull vinyl cap off end of tube enough to expose groove in tube (no need to remove motor). Clean groove in tube. Continue with instructions to install drive line cord.

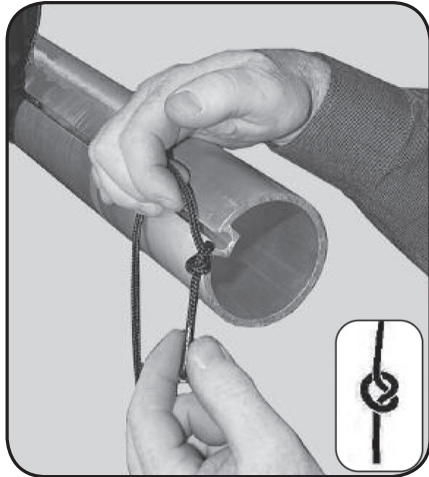

- 1** Tie a loose square knot at one end of new cord. Leave knot loose and insert it into groove on roll tube.

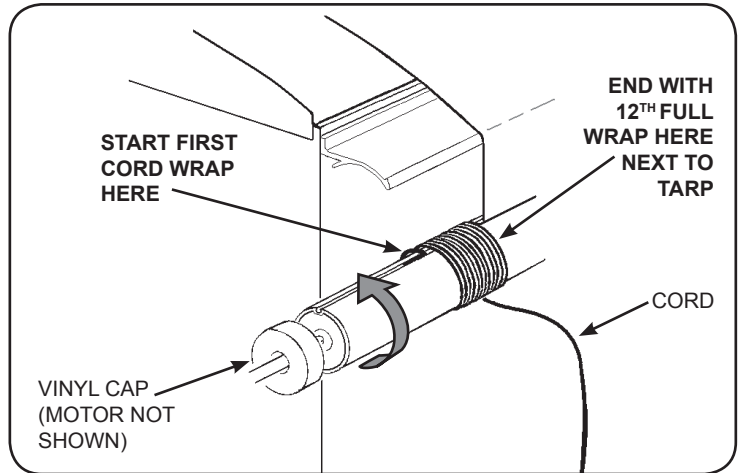

- 2** Slide loose knot over inside of groove and pull cord tight to set knot. **See 3 and 4 for wrapping direction of cord. (view above is at front)** Start wrapping with each new wrap towards tarp. Do 12 full wraps. Adjust wraps to set neatly side by side and positioned so last wrap is approximately 1" away from tarp.

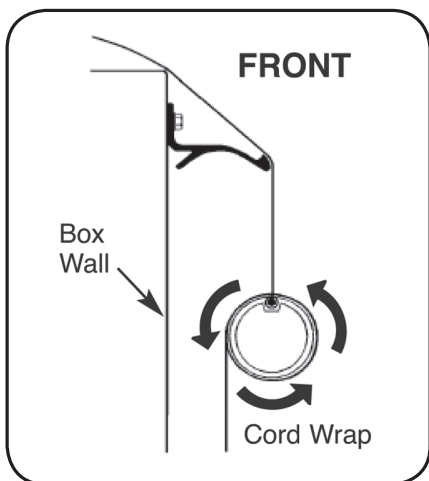

- 3** Follow wrapping direction in this view when replacing cord at front end of roll tube.

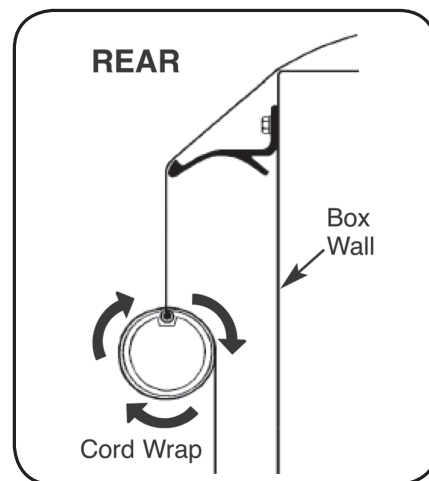

- 4** Follow wrapping direction in this view when replacing cord at rear end of roll tube.

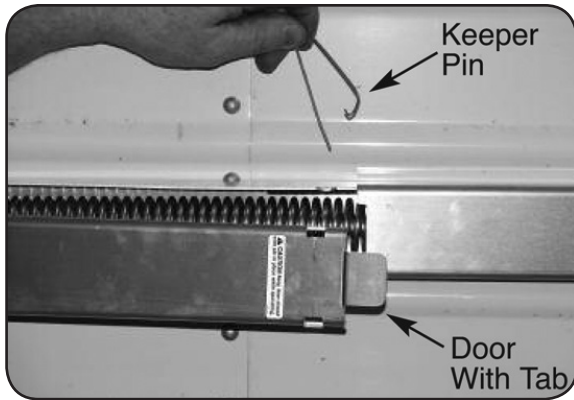

- 5 Remove keeper pin at center of spring box doors. Slowly swing doors open, hold on to pulley end of tension spring and let it hang down for now.

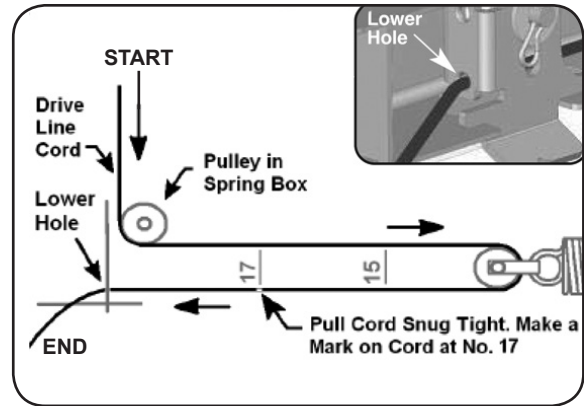

- 6 Route replacement cord around pulley in spring box, lift end of spring up horizontally, feed cord around pulley and over into lower hole in end of spring box. Pull cord snug tight and **make a mark on it in line with number 17** etched in spring box wall.

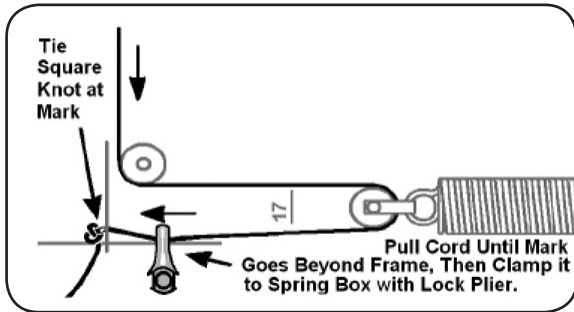

- 7 Pull on cord (stretching spring while doing so) until mark is visible beyond pulley frame, leaving enough room to tie a square knot. Then clamp cord to spring box with lock pliers. Tie square knot at mark on cord.

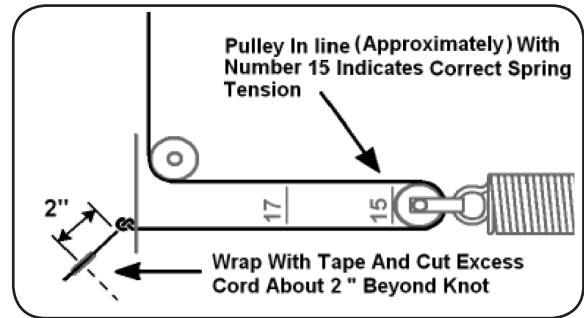

- 8 Hold cord firmly, release lock pliers and gradually let spring pull cord tight up to knot. Spring is properly tensioned when pulley settles back and lines up approximately with number 15 on spring box. Wrap tape around area of cord to allow about 2 inches of cord after cutting off excess.



- 9 Swing doors closed. Reinsert keeper pin. Reconnect power and test tarp operation. Make adjustments if needed.

NOTE: Always make sure drive lines are tensioned equally at front and rear of tarp.

CAUTION Keep door closed with pin in place while operating.

60880_INIT