

ROLL UP TRUCK BOX COVER SPECIAL SIDE RAIL CLAMPING INSTRUCTIONS



2008-14 FORD F-150 WITH SIDE RAIL KIT

Read and follow these special instructions along with the standard instructions carefully before installing or using this cover.

NOTICE TO INSTALLER: Even if familiar with product, read special instructions prior to installation as improvements may be made without notice. Always handle components with care. When done, these special instructions must be given to the consumer.

NOTICE TO CONSUMER: Before using this product, read special instructions. Save these special instructions for future reference.

NOTICE TO INSTALLER/CONSUMER: These instructions supersede the side rail installation step found in the standard instructions. After side rails are installed, resume standard instructions.

PREPARATION

TOOLS NEEDED

- (1) 1/2" Wrench
- (1) Protective eyewear

⚠ CAUTION: Over torquing hardware may damage components. Do not use impact tools.

1. ASSEMBLE CLAMPS

A. Assemble 3 long clamps with carriage bolt, clamp plate and flange nut. Then insert clamps in cargo rail as illustrated (the 2 short clamps are used at rear).

NOTE: Some models only include 2 long clamps.

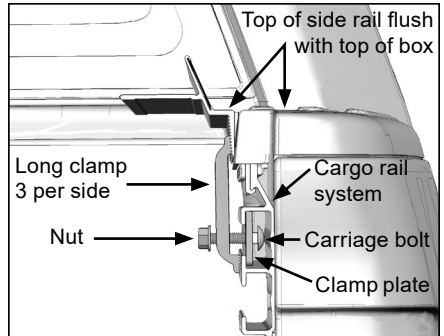

2. INSTALLING SIDE RAILS

A. Use standard instructions for the correct height and position of side rail. Space each long clamp as shown and turn nuts finger tight for now.

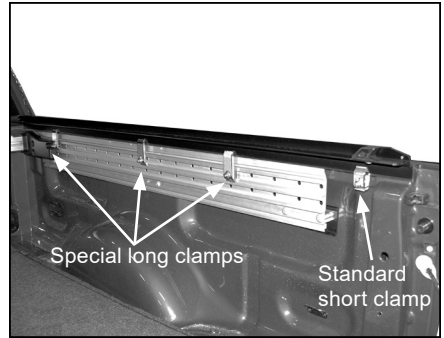

B. At front, position clamp next to header bar and as far forward as possible, or if no header cross bar, near end of cargo rail.

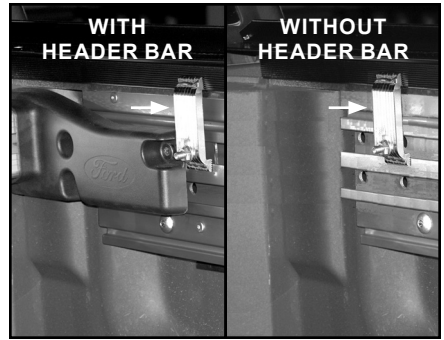

C. At rear of side rail, install 1 short clamp. Follow the standard instructions to adjust rear clamp and side rail for tailgate clearance. Then tighten the short clamp and all long clamps. Repeat Steps 1 and 2 to install side rail on opposite side.

D. **For remaining cover installation, refer to standard instructions.**

