

ROLL UP TRUCK BOX COVER SPECIAL BOLT ON SIDE RAIL INSTRUCTIONS

2001-05 CHEVY/GMC 6' 6" STEPSIDE COMPOSITE BOX

Read and follow these special instructions along with the standard instructions carefully before installing or using this cover.

NOTICE TO INSTALLER: Even if familiar with product, read special instructions prior to installation as improvements may be made without notice. Always handle components with care. When done, these special instructions must be given to the consumer.

NOTICE TO CONSUMER: Before using this product, read special instructions. Save these special instructions for future reference.

NOTICE TO INSTALLER/CONSUMER: These instructions supersede the side rail installation step found in the standard instructions. After side rails are installed, resume standard instructions.

PREPARATION

TOOLS NEEDED

- (1) Ratchet with 7/16" socket and 5/16" socket
- (1) 5/16" Wrench
- (1) Drill with 1/4" bit
- (1) Protective eyewear

⚠ CAUTION: Over torquing hardware may damage components. Do not use impact tools.

IMPORTANT: Before installing this product, ensure truck has composite walls inside box and does not have inside lip.

TOP VIEW OF COMPOSITE BOX

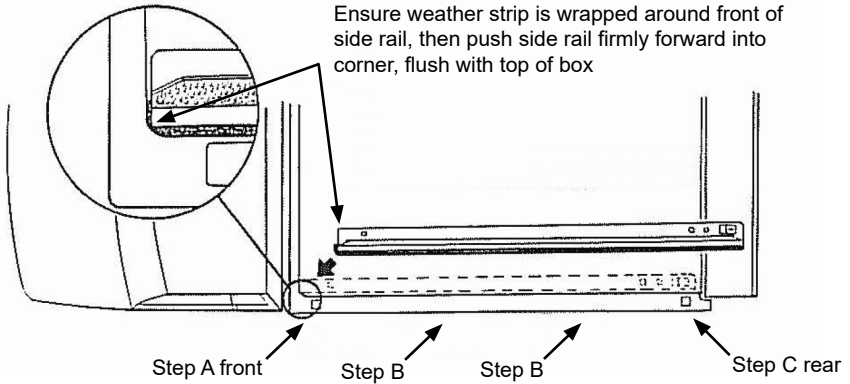

Push side rail forward against front of box and align as shown in following steps. Use pre-punched holes in side rail as guide for drilling locations. Work front to back.

1. INSTALLING SIDE RAILS

A. With side rail in position as shown, drill 1/4" hole through composite and steel stake pocket. Use bolt, washer and lock nut to fasten tight.

NOTE: Use 5/16" wrench to tighten bolt and 7/16" socket with ratchet for nut.

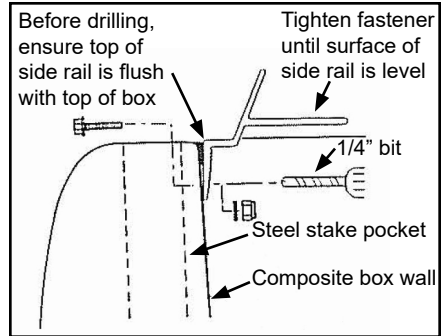

B. At second pre-punched hole, hold side rail flush with top of box. Turn self-drilling screw through wall and into steel brace. Repeat this step at third hole.

▲ CAUTION: Carefully turn self-drilling screw to ensure it does not strip threads.

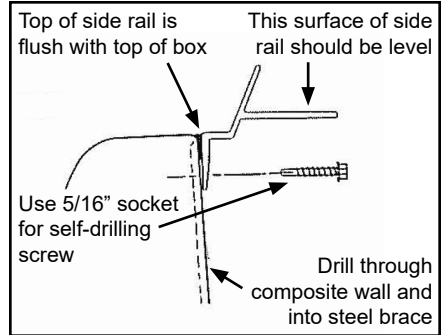

C. Align side rail height with tailgate. Drill 1/4" hole into composite wall and stake pocket. Use bolt, washer and lock nut to fasten.

D. Repeat Step 1 to install side rail on opposite side.

E. For remaining cover installation, refer to standard instructions.

