

ROLL UP TRUCK BOX COVER SPECIAL BOLT ON SIDE RAIL INSTRUCTIONS



2009-ON DODGE RAM WITH RAMBOX CARGO MANAGEMENT SYSTEM

Read and follow these special instructions along with the standard instructions carefully before installing or using this cover.

NOTICE TO INSTALLER: Even if familiar with product, read special instructions prior to installation as improvements may be made without notice. Always handle components with care. When done, these special instructions must be given to the consumer.

NOTICE TO CONSUMER: Before using this product, read special instructions. Save these special instructions for future reference.

NOTE TO CONSUMER AND INSTALLER: Side rails in this kit mount to the cargo rail system with special bolt on brackets instead of standard clamps as shown in standard instructions.

PREPARATION

TOOLS NEEDED

- In-lb Torque wrench with 10 mm socket
- Ratchet with short extension and 7/16" socket
- 7/16" Wrench
- Tape measure
- Utility knife or scissors
- Protective eyewear

⚠ CAUTION: Over torquing hardware may damage components.

⚠ CAUTION: Always exercise caution when using a utility knife.

NOTE: For best adhesion, ensure air and surface temperatures are above 60° F.

NOTE: Hardware appearance and components may vary.

1: INSTALLING SEALS

A. Remove (5) factory bolts holding OEM cargo rail or tonneau rail in place. OEM cargo rail or tonneau rail is loosely attached to box with (2) nylon anchors. Starting at front, pull until anchors disengage and cargo rail is free from box.

NOTE: OEM tonneau rail will not be reinstalled. Installer should return OEM tonneau rail to owner.

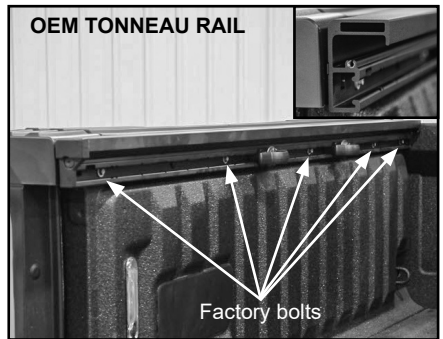
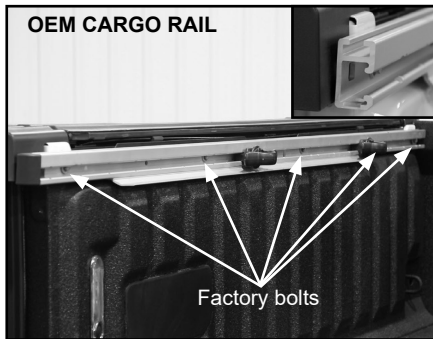

NOTE: For best adhesion, ensure air and surface temperatures are above 60° F.

B. Ensure bulkhead is clean, wipe top surface with alcohol pad. Gently lift front of bed cap and apply black sealant at inner edge of bed cap.

IMPORTANT: Save alcohol pad for later use.

C. Repeat Steps 1A-B for opposite side.



1: INSTALLING SEALS (Continued)

NOTE: With a spray-in bed liner, better adhesion is possible by smoothing surface and applying an adhesion promoter.

IMPORTANT: Ensure raised portion of seal is against inside edge of box while unraised portion is toward cab.

D. Starting at one end, peel protective backing as you go. Align and adhere seal against black sealant and inside edge of box to opposite corner and cut to length.

E. Firmly press adhesive along seal.

Perform one of the following to install flat seal:

1500 MODELS

F. Ensure inner bed wall at front and rear of RamBox is clean, then wipe with alcohol pad. Adhere flat seal flush with top of painted edge and 1" past edge of RamBox. Ensure flat seal does not interfere with operation of RamBox.

G. Repeat for opposite side.

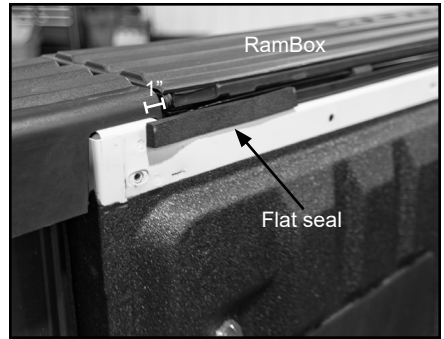
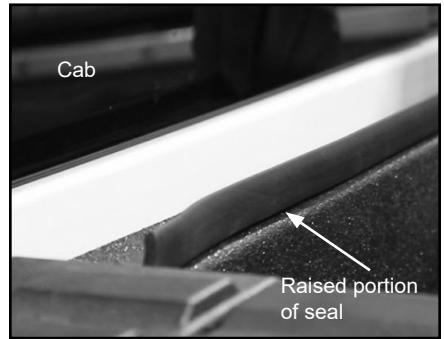

2500/3500 MODELS

F. Ensure inner bed wall below RamBox is clean, then wipe with alcohol pad. Starting at front, peel protective backing as you go. Ensuring flat seal contacts bulkhead, align and adhere flat seal to inner bed wall with seal flush with top of RamBox gutter. Continue past inner bed wall to end of bed cap, trim excess seal.

G. Repeat for opposite side.

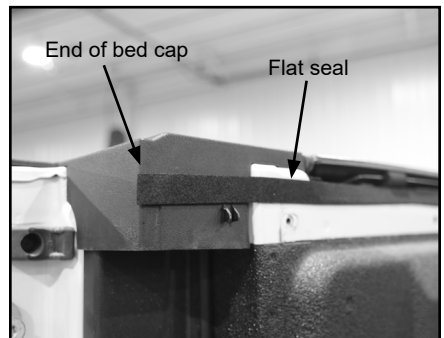
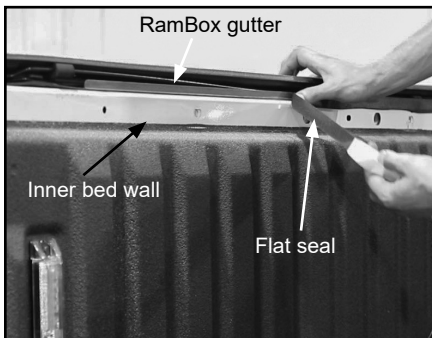

2: INSTALLING SIDE RAILS

NOTE: Front and middle brackets are the same, rear brackets are side specific.

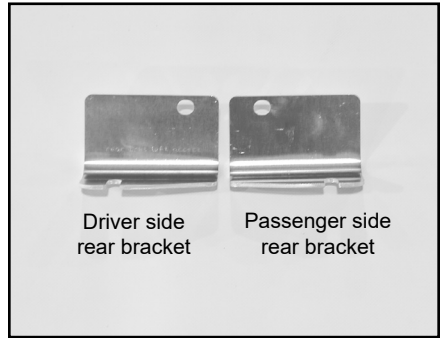

A. Place lock washer and flat washer on bolt, then insert bolt through circular hole in bracket. Place spacer on bolt, then insert through side rail and finger tighten serrated flange nut.

B. Repeat for all brackets.

NOTE: 1500 models have (3) brackets, 2500/3500 models have (4) brackets.

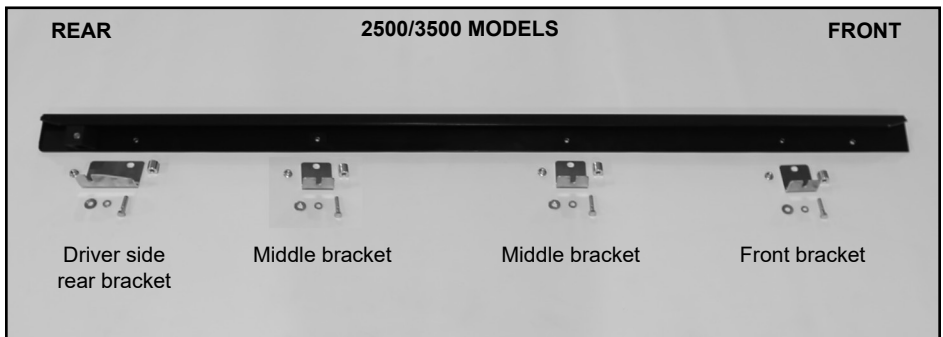
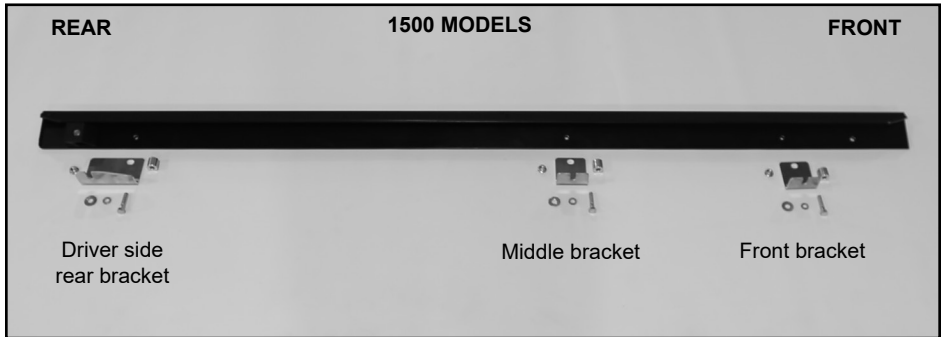
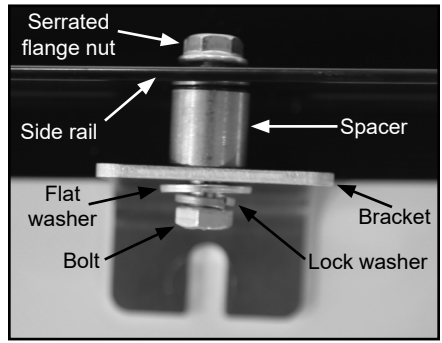

2: INSTALLING SIDE RAILS (Continued)

NOTE: Side rail seal should be flush with RamBox.

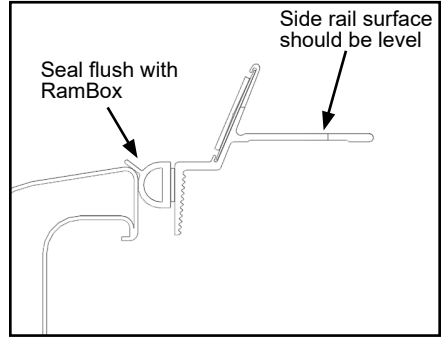

Perform one of the following to install side rails:

OEM TONNEAU RAIL

- A. Align holes in side rail brackets with holes in box.
- B. Starting at the front, reinsert and tighten factory bolts in side rail brackets.

NOTE: Reinstall factory bolts at (2) hole locations not used for side rail installation.

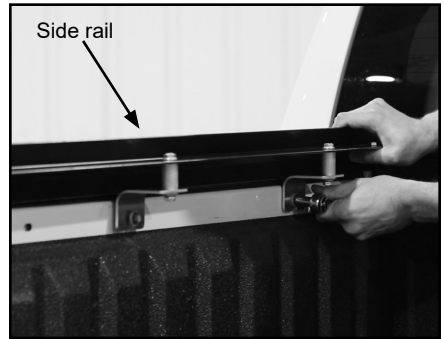

OEM CARGO RAIL (TYPICALLY SILVER)

- A. Align holes in cargo rail with holes in box. Attach cargo rail to box with (2) nylon anchors.
- B. Starting at the front, reinsert and start threading factory bolts into box, do not fully tighten.
- C. Set side rail over cargo rail. Push side rail down ensuring brackets slide over factory bolts, then starting at the front fully tighten.

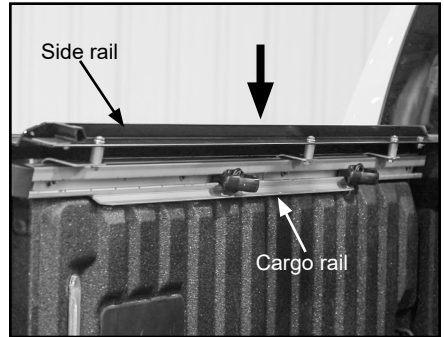

2: INSTALLING SIDE RAILS (Continued)

BOTH TONNEAU AND CARGO RAIL

D. Trim 1/2" off adhesive side of tailgate seal to fit rounded inside corner where tailgate meets box rail.

▲ CAUTION: Always cut away from yourself and others.

1500 MODELS

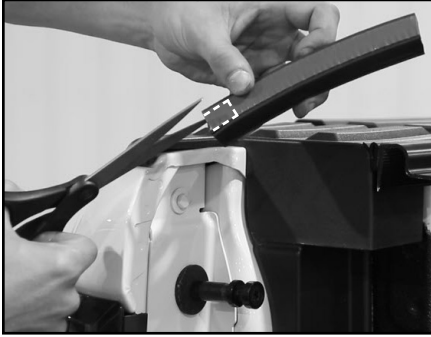

2500/3500 MODELS



E. Clean area with alcohol pad. Ensure trimmed side of seal is at corner of box, then peel protective backing and press to adhere.

1500 MODELS

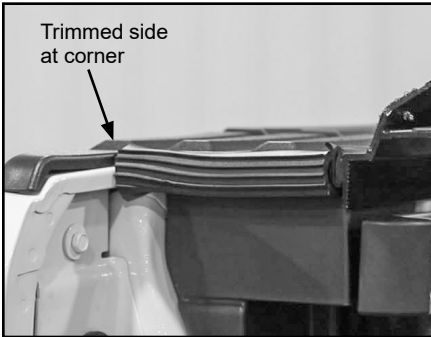

2500/3500 MODELS

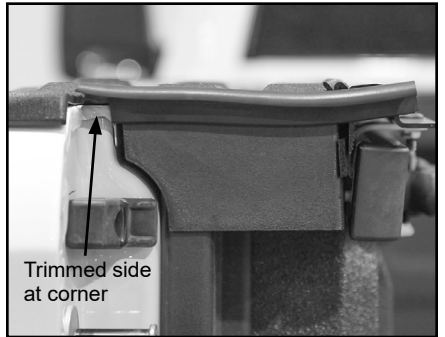

2: INSTALLING SIDE RAILS (Continued)

ALL MODELS

F. Clean underside of side rail with alcohol pad. Hold rail seal up to end of side rail, ensure end of seal contacts edge of box.

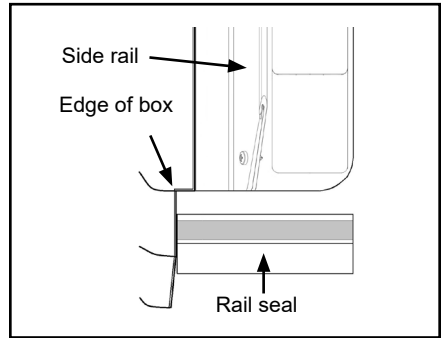

G. Mark seal leg, then cut notch in seal.

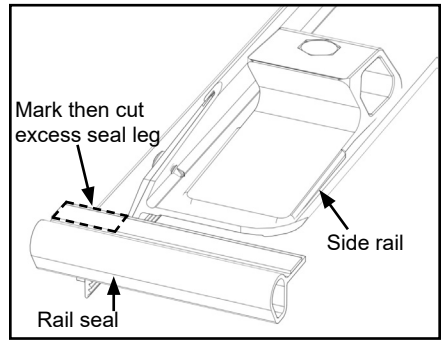

H. Peel protective backing, align and adhere seal to end of side rail, ensuring rail seal contacts tailgate seal.

I. Repeat on opposite side.

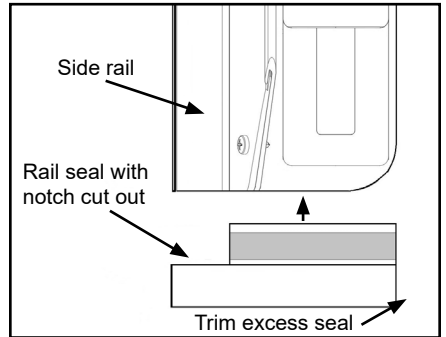

2: INSTALLING SIDE RAILS (Continued)

J. Rail seal installed.

1500 MODELS

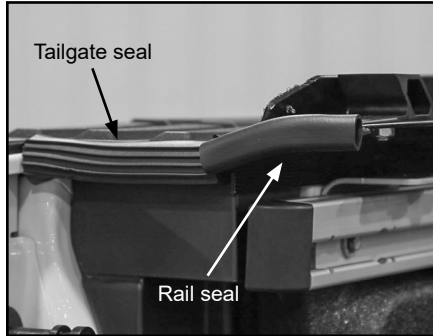

2500/3500 MODELS

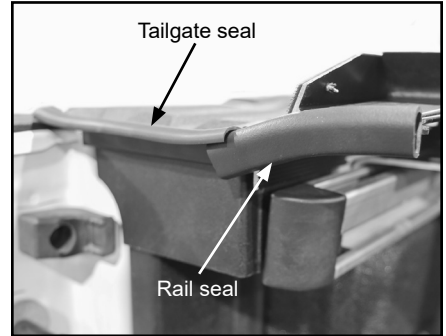

K. Ensure RamBox lid opens and closes without interference from side rail.

NOTE: If RamBox lid rotates too tight against seal when opening, adjust side rail as needed to allow proper operation.

L. Torque factory bolts to 65 in-lbs (5.5 ft-lbs), then fully tighten serrated flange nuts holding side rail to side rail bracket.

M. Repeat Step 2 to install side rail on opposite side.

N. For remaining cover installation, refer to standard instructions.

