

FRONT HARD COVER SEAL INSTALLATION INSTRUCTIONS

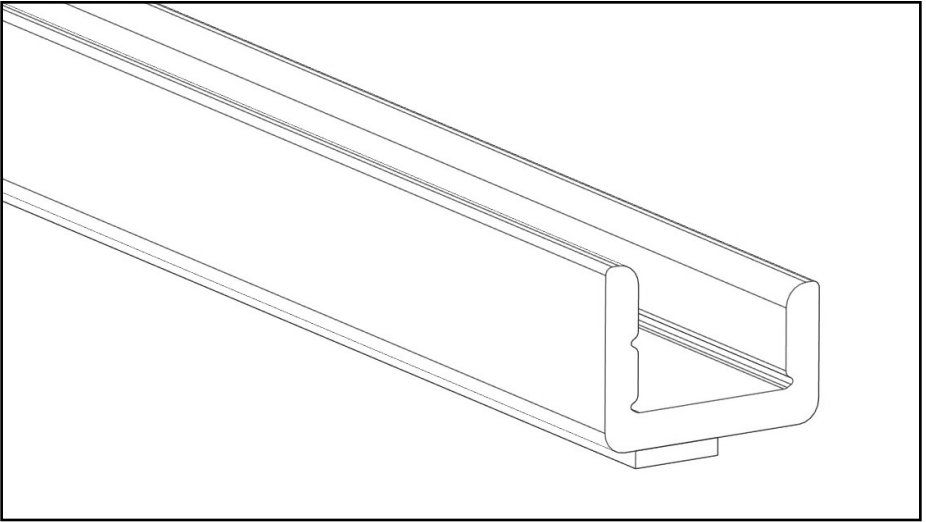

NOTICE TO INSTALLER: Even if familiar with product, read these instructions prior to installation as improvements may be made without notice. Always handle components with care. When done, these instructions must be given to the consumer.

NOTICE TO CONSUMER: Before using this product, read instructions. Save these instructions for future reference.

PREPARATION

COMPONENTS

- Seal
- Alcohol pad

TOOLS NEEDED

- Cleaning supplies (optional)
- Scissors
- Protective eyewear

NOTE: Side rail shape may vary. Install this kit after installing side rails and before mounting cover. If cover was installed previously, remove from rails.

NOTE: For additional protection against the elements, locate and seal miscellaneous factory holes, crevices, stake pockets, etc. that may be in box (sealant not included).

1: APPLYING SEAL

NOTE: For best adhesion, ensure air and surface temperatures are above 60° F.

NOTE: With a spray-in bed liner, better adhesion is possible by smoothing surface and applying an adhesion promoter.

A. Ensure bulkhead is clean, wipe top surface with alcohol pad (if needed wash and dry surface first).

NOTE: If replacing previous seal, ensure previous seal, debris and remaining adhesive residue are completely removed.

B. Starting at one end, peel protective backing as you go. Align and adhere seal against front of side rail and inside edge of box to opposite corner and cut to length.

C. Firmly press adhesive along seal.



IMPORTANT: Ensure tall side of seal faces cab.

NOTE: Trim tall side of seal if necessary to ensure proper seal.

