

ROLL UP TRUCK BOX COVER SPECIAL BOLT ON SIDE RAIL AND HEADER BAR INSTRUCTIONS



2022-ON HYUNDAI SANTA CRUZ

Read and follow these special instructions along with the standard instructions carefully before installing or using this cover.

NOTICE TO INSTALLER: Even if familiar with product, read special instructions prior to installation as improvements may be made without notice. Always handle components with care. When done, these special instructions must be given to the consumer.

NOTICE TO CONSUMER: Before using this product, read special instructions. Save these special instructions for future reference.

NOTICE TO INSTALLER/CONSUMER: These instructions supersede the side rail installation step found in the standard instructions. After side rails are installed, resume standard instructions.

PREPARATION

IMPORTANT: Truck bed features restrict cover from fully opening. Truck is equipped with a trunk-like lid on box floor. Lid remains functional, however, restricted from fully opening. Avoid forcing lid beyond its limit.

TOOLS NEEDED

- Ratchet with 10mm and T-30 Torx sockets
- 10mm wrench
- In-lbs torque wrench
- Cutting tool
- Protective eyewear

⚠ CAUTION: Over torquing hardware may damage components.

NOTE: For best adhesion, ensure air and surface temperatures are above 60° F.

1: SIDE RAIL AND HEADER BAR INSTALLATION

A. Use T-30 Torx socket to remove first, second and fourth bolts on both sides of truck bed and outer (2) bolts on bulkhead.

NOTE: These bolts will be replaced with new hardware in Step 1B. Installers should return these bolts to the owner.

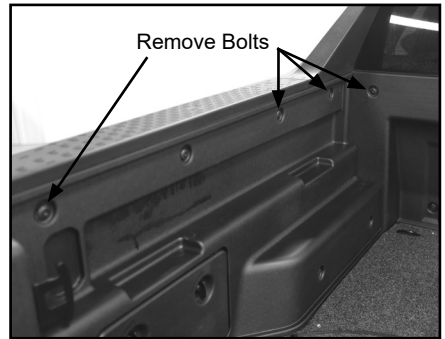

B. Place lock washer and flat washer on bolts. Insert 50mm bolts into small clamps and 60mm bolts into large clamps, slide spacers onto long leg of large clamps.

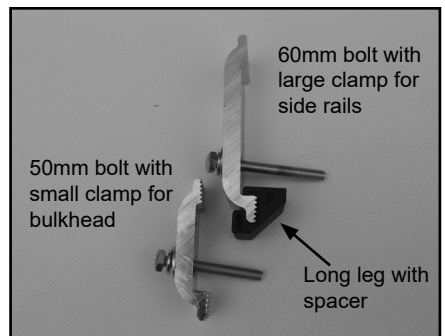
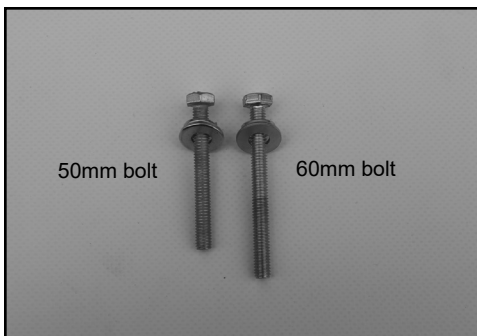

1: SIDE RAIL AND HEADER BAR INSTALLATION (Continued)

C. Ensure side of box is clean, wipe surface with alcohol pad. Apply side seal flush with top of bulkhead.

IMPORTANT: Save alcohol pad for later use.

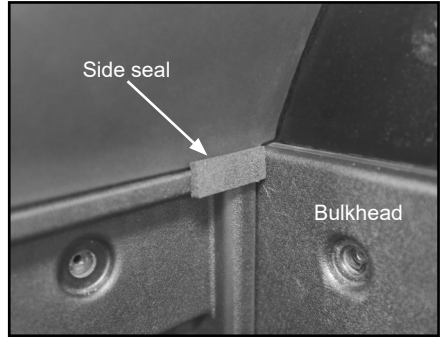

D. Place header bar against bulkhead ensuring header bar seal contacts bulkhead and side seal is slightly exposed above header bar.

E. Install 50mm bolt and clamp assembly into factory hole and finger tighten.

F. Repeat on opposite side of header bar, torque both bolts to 70 in-lbs (5.8 ft-lbs).

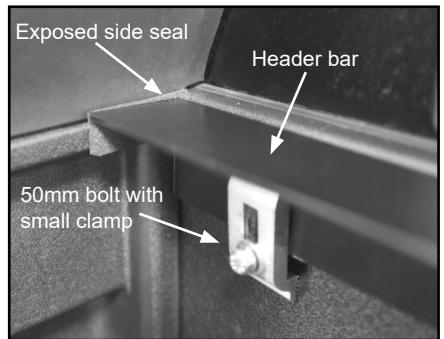

G. Install 60mm bolts and side rail clamp assemblies into factory holes. Leave clamps loose for now.

H. Position side rail with weather strip against inside lip of box. Push side rail forward until it touches the header bar.

I. Use standard instructions to determine correct height and position of side rail.

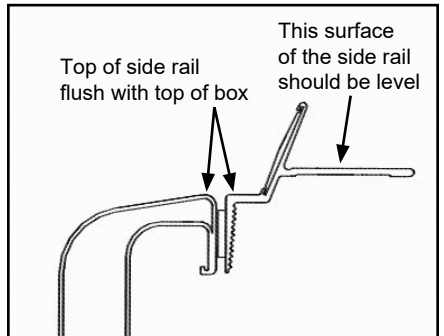

1: SIDE RAIL AND HEADER BAR INSTALLATION

(Continued)

J. Starting at the front, secure 60mm bolts and clamp assemblies into factory holes.

K. Torque bolts to 70 in-lbs (5.8 ft-lbs).

L. Repeat Steps 1G-K to install side rail on opposite side.

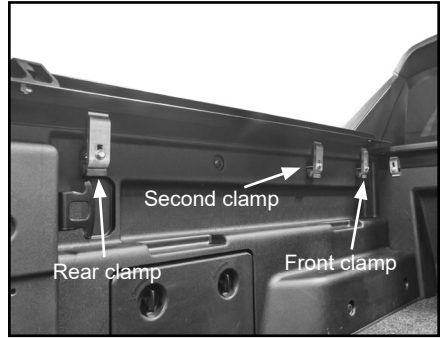

NOTE: If box has bed lights, ensure rear clamp is not touching bed light cover.

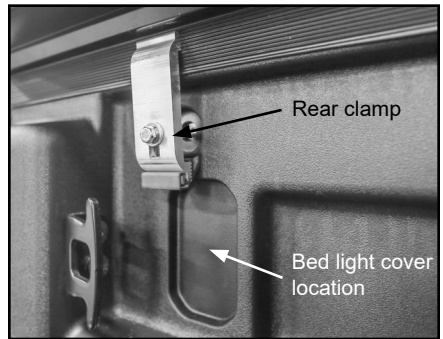

M. Ensure header bar is clean, wipe top surface with alcohol pad.

N. Starting at one end, peel protective backing off seal gasket. Ensure seal gasket is touching both side rail and plastic molding. Adhere along header bar to opposite corner and cut to length.

IMPORTANT: Ensure raised portion of seal gasket is against inside edge of header bar while unraised portion is toward cab.

O. For remaining cover installation, refer to standard instructions.

