

ROLL UP TRUCK BOX COVER SPECIAL BOLT ON SIDE RAIL INSTRUCTIONS



2004-09 FORD F-150 FLARESIDE BOX

Read and follow these special instructions along with the standard instructions carefully before installing or using this cover.

NOTICE TO INSTALLER: Even if familiar with product, read special instructions prior to installation as improvements may be made without notice. Always handle components with care. When done, these special instructions must be given to the consumer.

NOTICE TO CONSUMER: Before using this product, read special instructions. Save these special instructions for future reference.

NOTICE TO INSTALLER/CONSUMER: These instructions supersede the side rail installation step found in the standard instructions. After side rails are installed, resume standard instructions.

PREPARATION

TOOLS NEEDED

- (2) 1/2" Hex-head wrenches
- (1) Drill and 5/16" drill bit
- (1) Foot-pound torque wrench with 1/2" socket
- (1) Marking pen
- (1) Protective eyewear
- (1) Tape measure or ruler

⚠ CAUTION: Over torquing hardware may damage components. Do not use impact tools.

1. INSTALLING SIDE RAILS

A. Mark and drill holes on inside of box lip. Follow dimensions shown along with diagram in Step 1C.

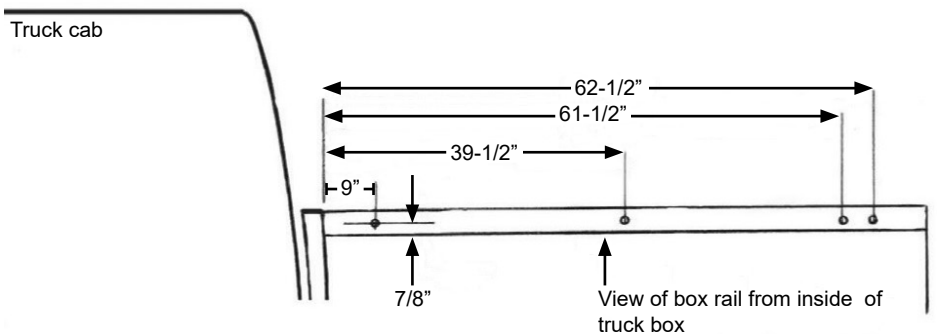

1. INSTALLING SIDE RAILS (Continued)

B. Set notched end of side rail on top of box behind cab.

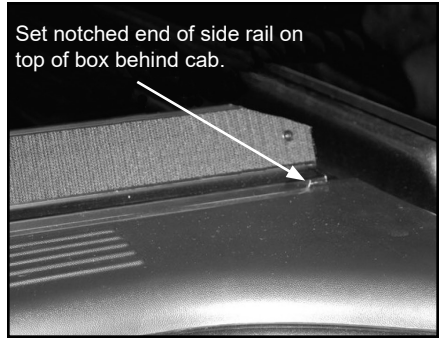

C. Start with clamp at front of box and work toward tailgate. Adjust clamps up or down until side rail is level after clamps have been tightened.

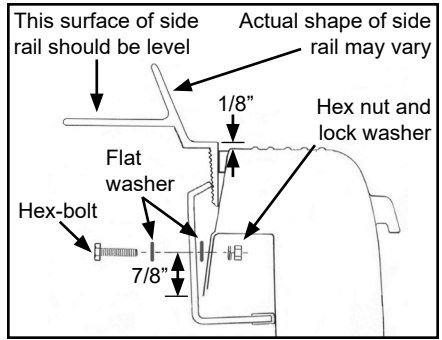

D. Lower side rail at rear until it is aligned 1/8" above box at center clamp location. After center clamp is tight, raise rear of side rail to correct height and position based on standard instructions and tighten rear clamp. Repeat Step 1 to install side rail on opposite side.

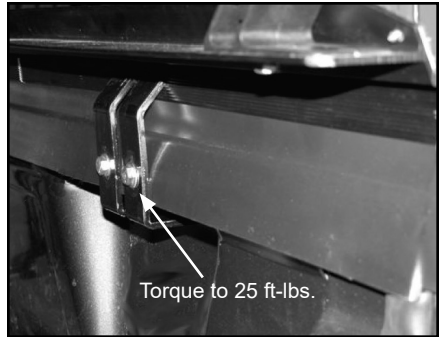

E. Torque all clamps to 25 ft-lbs.

F: **For remaining cover installation, refer to standard instructions.**

