

# ROLL UP TRUCK BOX COVER SPECIAL BOLT ON SIDE RAIL INSTRUCTIONS

## 2003-06 TOYOTA TUNDRA STEPSIDE BOX

Read and follow these special instructions along with the standard instructions carefully before installing or using this cover.

**NOTICE TO INSTALLER:** Even if familiar with product, read special instructions prior to installation as improvements may be made without notice. Always handle components with care. When done, these special instructions must be given to the consumer.

**NOTICE TO CONSUMER:** Before using this product, read special instructions. Save these special instructions for future reference.

**NOTICE TO INSTALLER/CONSUMER:** These instructions supersede the side rail installation step found in the standard instructions. After side rails are installed, resume standard instructions.

# PREPARATION

## TOOLS NEEDED

- (1) 5/16" Box wrench
- (1) Drill with 1/8" drill bit
- (1) Inch-pound torque wrench with 5/16" socket
- (1) Protective eyewear

**▲ CAUTION:** Over torquing hardware may damage components. Do not use impact tools.

## 1. INSTALLING SIDE RAIL

A. Wash top of bulkhead and each front corner. Let dry and then prep surface with alcohol pads supplied in kit to ensure sufficient adhesion of hook strips.

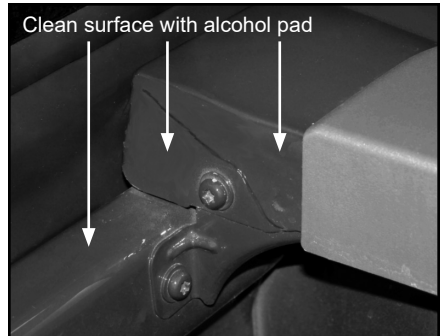

B. Adhere 2" long hook strips to side of each corner. Adhere 54" long hook strip to top of bulkhead. Apply pressure to ensure maximum adhesion. At each corner, adhere weather seal piece flush at top of box with thick edge next to plastic rail cap. This fills indent in box.

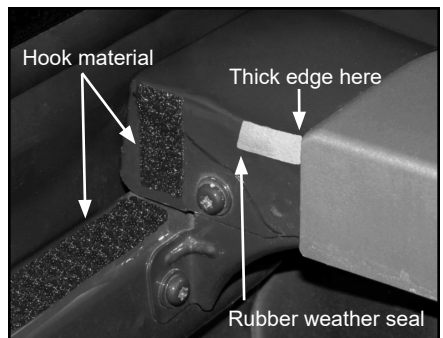

# 1. INSTALLING SIDE RAIL (Continued)

C. At rear of box, align edge of side rail even with rear edge of box and hold. At front of box, align side rail with top of box and hold. Then at front use pre-punched hole in side rail as guide to drill 1/8" hole. Turn metal fastener in and tighten to 70 in-lbs.

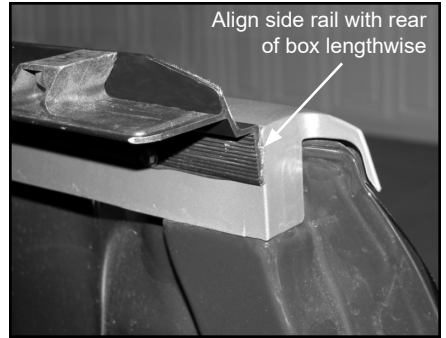

D. Move to second pre-punched hole in side rail. Align side rail with top of box and drill 1/8" hole. Then turn metal fastener in and tighten to 35 in-lbs. Repeat this procedure for 3rd hole from front of box.

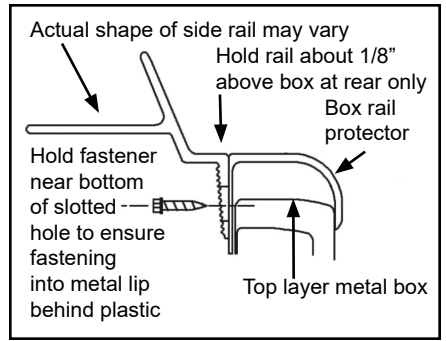

E. At rear of box, raise side rail up 1/8" above box. Use pre-punched hole in side rail as guide and drill 1/8" hole. Turn fastener in and tighten to 70 in-lbs. Repeat Steps C, D and E for side rail on opposite side of box.

**NOTE:** Ensure all fasteners are tightened to correct in-lbs. Torque 2 center locations to 35 in-lbs. Torque the front and rear locations to 70 in-lbs.

**IMPORTANT:** In the standard instructions, complete "Installing Tension Adjusters", and then proceed to Step 1F in these special instructions.

F. Set cover at front of box on side rails (behind cab). Fold loop strips on vinyl edges so they seal to hook strips on box.

G. For remaining cover installation, refer to standard instructions.

