

# HARD TRUCK BOX COVER SPECIAL BOLT ON SIDE RAIL INSTRUCTIONS



## **2012-18 RAM 1500, 2019-20 RAM 1500 CLASSIC & 2012-ON RAM 2500, 3500 WITH RAMBOX CARGO MANAGEMENT SYSTEM**

Read and follow these special instructions along with the standard instructions carefully before installing or using this cover.

**NOTICE TO INSTALLER:** Even if familiar with product, read special instructions prior to installation as improvements may be made without notice. Always handle components with care. When done, these special instructions must be given to the consumer.

**NOTICE TO CONSUMER:** Before using this product, read special instructions. Save these special instructions for future reference.

**NOTE TO CONSUMER AND INSTALLER:** Side rails in this kit replace the cargo rail system and use special bolt on clamps.

# PREPARATION

## TOOLS NEEDED

- Ratchet with short extension and 10 mm socket
- In-lbs Torque wrench
- Protective eyewear
- Scissors

**▲ CAUTION:** Over torquing hardware may damage components.

**NOTE:** Hardware appearance and components may vary.

## 1: REMOVING CARGO RAIL

A. Remove bolts that mount cargo rail to box with 10 mm socket.

**NOTE:** These bolts will be replaced with new hardware. Installer should return bolts to owner.

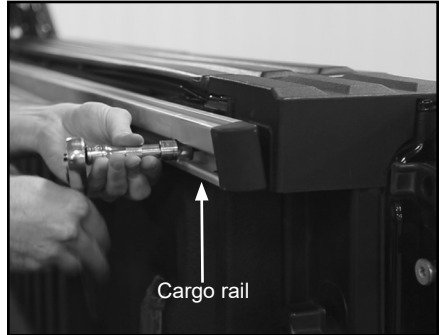

B. Cargo rail is still loosely attached to box with nylon anchors. Starting at front, pull cargo rail until anchors disengage and cargo rail is free from box. Installer should return cargo rail to owner.



## 2: INSTALLING NEW HARDWARE FOR SIDE RAIL

A. At front, insert bolt with lock washer and flat washer through hole in clamp without spacer and start threads. Leave bolt loose for now. Ensure clamp is long leg down.

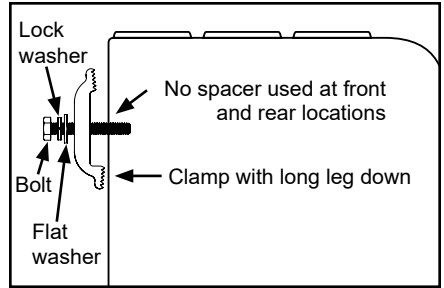

B. At middle bolt hole locations from cargo rail, insert bolt with lock washer and flat washer through hole in clamp. On opposite side, slide a spacer over end of each bolt.

C. Turn bolts to engage several threads. Leave bolts loose for now. Ensure clamps are long leg down.

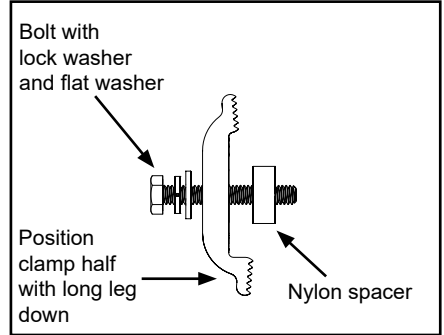

D. At rear, insert bolt with lock washer and flat washer through hole in clamp without spacer and start threads. Leave bolt loose for now. Ensure clamp is long leg down.

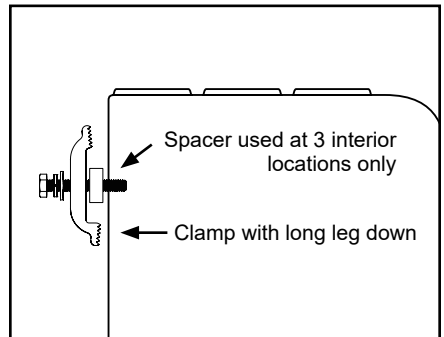

## 3: INSTALLING SIDE RAIL

**NOTE:** Refer to standard instructions for side rail orientation.

A. Position top of side rail flush with top of box at tailgate height and between all clamps and box wall. Push side rail forward until it touches front of box.

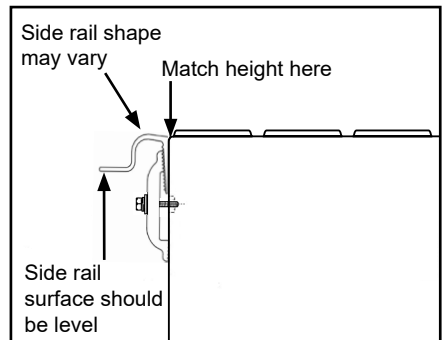

### 3: INSTALLING SIDE RAIL (Continued)

B. At front of box, turn bolt finger tight.

C. At rear of box, turn bolt finger tight.

D. Turn middle bolts finger tight.

**IMPORTANT: Ensure all clamp teeth engage side rail grooves.**

E. Torque all clamps to 70 in-lbs.

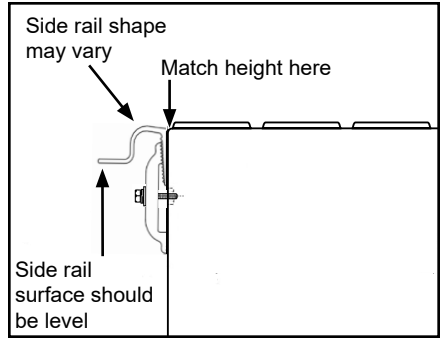

F. Ensure RamBox lid opens and closes without interference from side rail.

**NOTE:** If RamBox lid rotates too tight against seal when opening, try lowering the side rail slightly.



**NOTE:** For best adhesion, ensure air and surface temperatures are above 60° F.

G. Clean corner of side rail and bed cap at front of box with alcohol pad. Peel off protective backing from 1" wedge seal and press seal into cleaned area. Save alcohol pad.

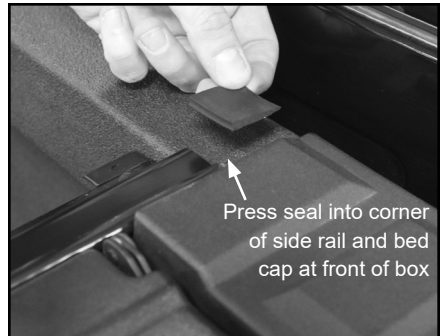

**NOTE:** For tailgates with a large gap, trim 6" tailgate seal to fit rounded inside corner where tailgate meets box rail. Clean area with alcohol pad, peel protective backing and press to adhere.

H. Repeat Steps 1-3 to install side rail on opposite side.

I. For remaining cover installation, refer to standard instructions.

