

ROLL UP TRUCK BOX COVER SPECIAL RAIL INSTRUCTIONS



2020-ON RAM 1500 WITH MULTIFUNCTION TAILGATE

Read and follow these instructions along with the standard instructions carefully before installing or using this cover.

NOTICE TO INSTALLER: Even if familiar with product, read special instructions prior to installation as improvements may be made without notice. Always handle components with care. When done, these instructions must be given to the consumer.

NOTICE TO CONSUMER: Before using this product, read special instructions. Save these instructions for future reference.

PREPARATION

TOOLS NEEDED

- 1/2" Wrench
- 1/2" Open end wrench
- Ft-lbs torque wrench with 1/2" socket
- Protective eyewear

▲ CAUTION: Over torquing hardware may damage components.

1: INSTALLING SIDE RAILS

A. Position side rail with weather strip against inside lip of box. Align end of side rail with straight, inside edge of bulkhead.

IMPORTANT: Side rail is notched at front to compensate for corner bracket. Side rail will seal against bed cap in this area when clamped tight.

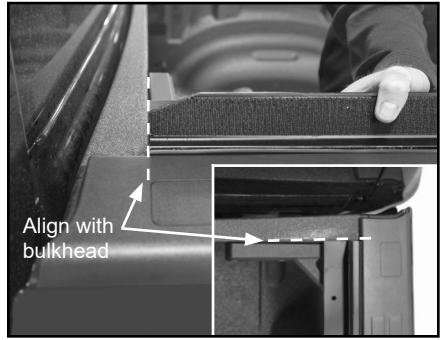

B. Adjust top of side rail until flush with top of box and hold with assistance of another person or a spring clamp.

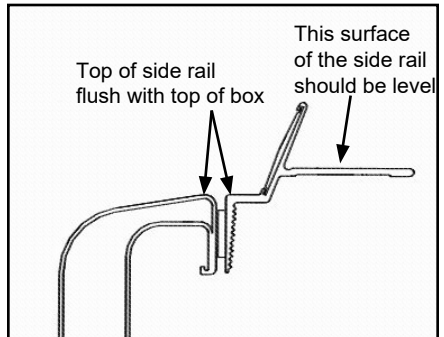

1: INSTALLING SIDE RAILS (Continued)

C. Install first clamp as close to front of box as possible then use 1/2" wrench to tighten.

IMPORTANT: To keep side rail secured on truck, ensure clamp teeth engage grooves on side rail, turn nut finger tight, then use wrench to finish tightening.

D. For remaining cover installation, refer to standard instructions.

NOTE: Tension adjusters install per standard instructions using a 1/2" open end wrench.

