

HARD TRUCK BOX COVER SPECIAL CLAMP INSTRUCTIONS



2019-ON CHEVY/GMC 1500 & 2020-ON CHEVY/GMC 2500/3500

Read and follow these special instructions along with the standard instructions carefully before installing or using this cover.

NOTICE TO INSTALLER: Even if familiar with product, read special instructions prior to installation as improvements may be made without notice. Always handle components with care. When done, these special instructions must be given to the consumer.

NOTICE TO CONSUMER: Before using this product, read special instructions. Save these special instructions for future reference.

PREPARATION

TOOLS NEEDED

- 1/2" Wrench
- Ft-lbs torque wrench with 1/2" socket
- Protective eyewear

NOTE: Hardware appearance and components may vary.

⚠ CAUTION: Over torquing hardware may damage components.

1: CLAMP LOCATIONS

⚠WARNING: Ensure side rail is not resting on contour of bulkhead.

IMPORTANT: Install clamps where 2 layers of sheet metal are present.

A. Use standard instructions to position side rail then install clamps at locations identified below.

NOTE: If possible, install clamps at indents in box rail. If not, position just before indents in box rail toward tailgate.

IMPORTANT: 6' 6" boxes install second clamp at side rail splice or as close to side rail splice closest to cab.

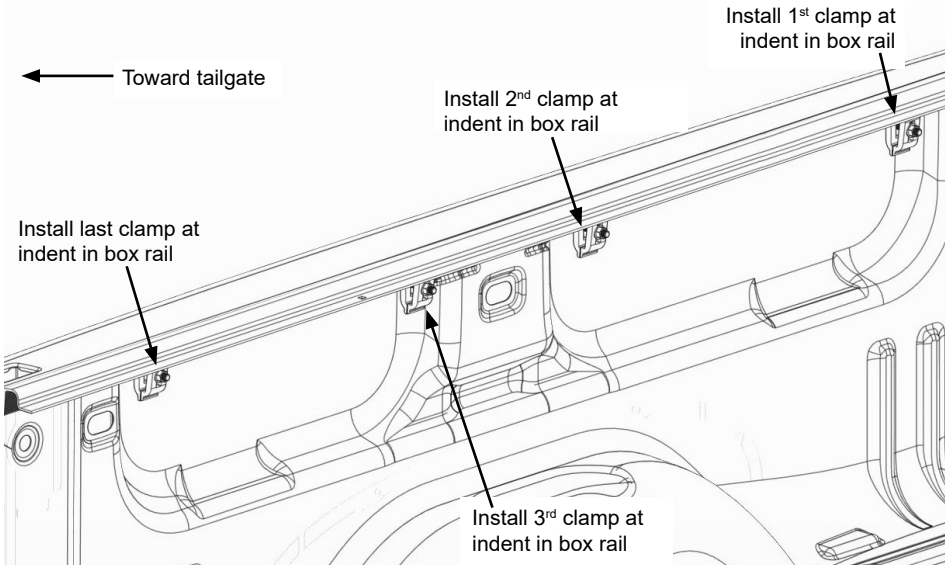
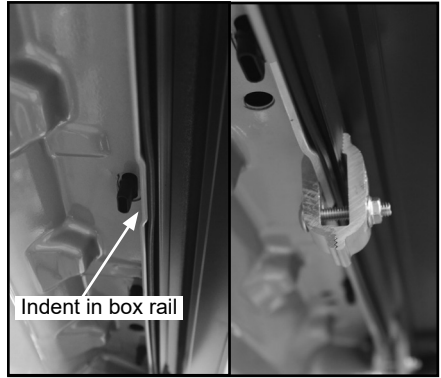

1: CLAMP LOCATIONS (Continued)

B. Ensure side rail is level, then torque clamps to 20 ft-lbs.

C. Repeat to install side rail on opposite side.

D. **For remaining cover installation, refer to standard instructions.**

