



# GRAIN CART / WAGON BOX DETAIL SHEET

Please complete form thoroughly. Missing information may delay order processing.

AGRI-COVER, INC.  
PO Box 508  
3000 Hwy 281 SE  
Jamestown, ND 58402

Phone: (800) 233-4655  
Fax: (800) 592-4460

www.agricover.com

GRAIN CART TARP KITS

**NOTE: Accurate PHYSICAL measurements are ESSENTIAL for proper tarp fit. Always use actual tape measurements. NEVER RELY ON UNIVERSAL BOX SIZES.**

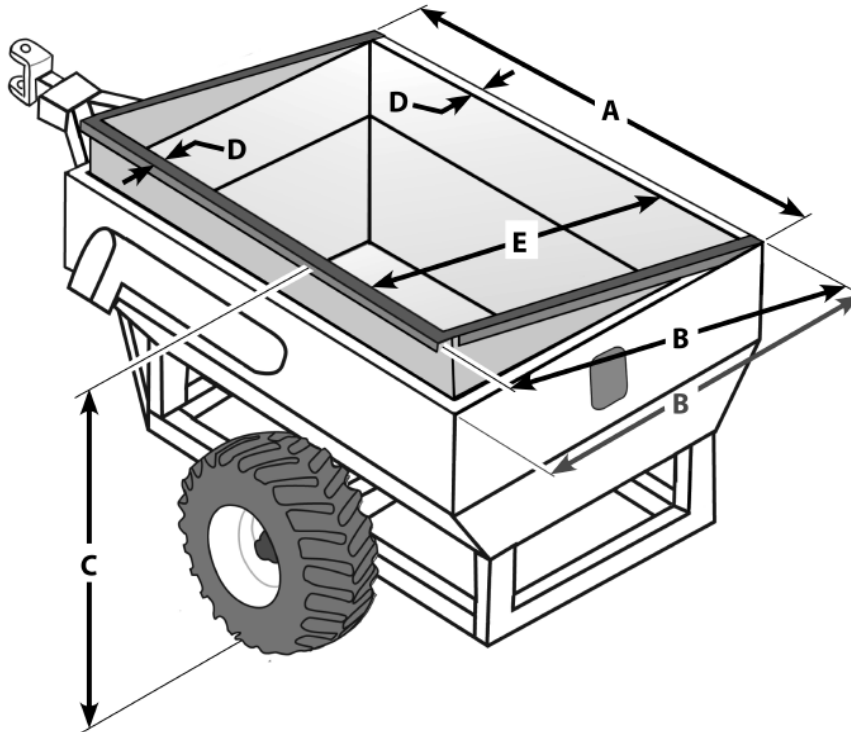

**IMPORTANT: Illustration shows measuring at top of angled extensions - or - If no extensions, measuring at top of box.**

**NOTE: If ordering flat or top mount end caps, make sure box is flat across top. Below is an example of a box with uneven angle across top from high side to low side. Flat or top mount caps will not fit this box. Order side mount caps for these boxes.**

Sales Representative: \_\_\_\_\_

**CONTACT INFORMATION**

Name \_\_\_\_\_

Address \_\_\_\_\_

City \_\_\_\_\_ State \_\_\_\_\_ Zip \_\_\_\_\_

Phone \_\_\_\_\_ Fax \_\_\_\_\_

Cart/Wagon Brand/Year \_\_\_\_\_

**TYPE OF TARP SYSTEM**

- |   |  |
|---|--|
| <input type="checkbox"/> SRT-2™ Manual                  | <input type="checkbox"/> EZ-LOC® Manual                  |
| <input type="checkbox"/> SRT-2™ Electric*               | <input type="checkbox"/> EZ-LOC® Electric*               |
| <input type="checkbox"/> SRT-2™ Wireless Remote Option* | <input type="checkbox"/> EZ-LOC® Wireless Remote Option* |

**TARP COLOR**

**Standard:**

- Black     White

**Optional\*:**

- Gray     Blue     Red     Orange  
 Green     Brown     Yellow     Multi-Color

**STYLE OF END CAPS**

- Galvanized Standard 12"  
 Aluminum\* Standard 12" (up to 118" wide only)  
 Stainless Steel\* Standard 12" (up to 118" wide only)  
 Galvanized Flat\* (138"-144" wide only)

**OUTSIDE DIMENSIONS**

- A \_\_\_\_\_ Top Outside Box Length  
 B \_\_\_\_\_ Top Outside Box Width  
 (If box has Extensions measure outside of extensions on the angle)  
 C \_\_\_\_\_ Box Height (from ground)  
 D \_\_\_\_\_ Top Rail Width  
 E \_\_\_\_\_ Inside Box Width

\* Optional items are additional cost

**By submitting this order, I accept the terms and conditions of Agri-Cover, Inc.**  
 Go online at [agricover.com](http://agricover.com) for videos, instructions, order forms, and product information.