



# CUSTOMER SYSTEMS GUIDE

EFFECTIVE DECEMBER 1, 2017



TESTED. TRUSTED. GUARANTEED.  
AMERICAN MADE

# AGRI-COVER, INC. POLICIES AND CONDITIONS OF SALE

All orders will receive prompt attention.

## **TERMS OF SALE:**

Net 30 days on approved credit. A 1-1/2% per month service charge will be added after 30 days. All accounts that are not able to meet with our terms will be placed on a prepaid basis until paid in full. All amounts are payable in U.S. funds.

## **PRICES:**

All prices are effective at the time the order is processed and are subject to change without prior notice.

## **RETURNED MERCHANDISE:**

No returned merchandise will be accepted without prior authorization. No returns on special orders or used products. All approved returns require a valid RA number (Return Authorization number) and must have customer name and address clearly posted on the outside of the box or shipment will be refused. **MERCHANDISE OUT OVER 30 DAYS IS NOT RETURNABLE.**

## **ROUTING:**

Unless otherwise specified, all orders will be shipped promptly and in the most economical way.

## **TRANSPORTATION TERMS:**

Prices are F.O.B., AGRI-COVER, INC, JAMESTOWN, N.D.

## **DAMAGE OR SHORTAGE:**

Examine all shipments carefully. Claims for damages or shortage must be noted on the BOL and made immediately with the carrier. Parcel Post damages are to be reported to us immediately (photo may be required). Concealed shortage must be made within 10 days.

## **CUSTOMER SERVICE:**

In the event you need assistance with your order, please call our Customer Service Department at 800-233-4655. Our knowledgeable and courteous representatives are available Monday through Friday from 8:00am to 5:00pm CST.

## **CUSTOM PROJECTS:**

If our products do not specifically fit your needs, we can work with you to come up with a solution that will. Note: An engineering and manufacturing fee may be assessed in these situations.

## SUGGESTED PROCEDURES TO PRICE AND ORDER A TARP

### **TARP SYSTEMS**

1. Choose your application: See Table of Contents on Page 3 to direct you to the appropriate application.
2. Choose your system
  - a. Review the tarp system options.
  - b. Use the feature comparison chart (for chosen application) to see which tarp system will best fit your needs.
3. Measure your equipment
  - a. Refer to the diagrams on the box detail sheets located in the back of the book to determine what measurements are needed.
  - b. For best tarp fit, accurate physical measurements are needed.
4. For pricing, kit options and accessories
  - a. Select base price of tarp according to box length measurement. Example: If box length measures over 25'-0" round up to 26'-0" price line.
  - b. Review the options and accessories table to customize your system.
5. Fill out the appropriate box detail sheet completely

### **TO ORDER, SEND COMPLETED BOX DETAIL SHEET TO CUSTOMER SERVICE.**

**PHONE** 800-233-4655

**MAIL** PO BOX 508  
Jamestown, ND 58402

**FAX** 800-592-4460

**EMAIL** orderdesk@agricover.com

# TABLE OF CONTENTS

Agri-Cover, Inc. Policies and Conditions of Sale _____	2
Suggested Procedures to Price and Order a Tarp _____	2
<b>ELECTRIC CONVERSION KITS _____</b>	<b>4-7</b>
Why Choose Electric and Wireless _____	5
ROLTEC® Electric Tarp Conversion Kits _____	6
ROLTEC™ Electric Hopper Conversion Kits _____	7
<b>SEMI TRAILERS _____</b>	<b>8-11</b>
Semi Trailer Tarp Systems and Feature Comparison Chart _____	9
Semi Trailer Kit Pricing _____	10
Options and Accessories _____	11
<b>FARM TRUCKS, SEED TENDERS AND GRAIN CARTS _____</b>	<b>12-17</b>
Farm Truck, Seed Tender and Grain Cart Tarp Systems and Feature Comparison Chart _____	13
Farm Truck, Seed Tender and Grain Cart Features and Benefits _____	14
Farm Truck, Seed Tender Kit Pricing _____	14
Options and Accessories _____	15
Grain Cart Kit Pricing _____	16-17
Options and Accessories _____	16-17
<b>FERTILIZER, CONSTRUCTION AND STAINLESS STEEL _____</b>	<b>18-23</b>
Fertilizer, Construction and Stainless Steel Tarp Systems and Feature Comparison Chart _____	19
Fertilizer Spreader and Tender Box Kit Pricing _____	20
Options and Accessories _____	20
Semi Trailer and Farm Truck Kit Pricing _____	21
Options and Accessories _____	22
Construction Dump Box Kit Pricing _____	23
Options and Accessories _____	23
<b>BELLY DUMP _____</b>	<b>24-25</b>
Belly Dump Tarp System Kit Pricing _____	25
<b>BOX DETAIL SHEETS _____</b>	<b>26-35</b>
Semi Grain and Pup Trailer Box Detail Sheet _____	26
Semi Grain and Pup Trailer Electric Kit Box Detail Sheet _____	27
Farm Truck and Seed Tender Box Detail Sheet _____	28
Grain Cart and Grain Wagon Box Detail Sheet _____	29
Stainless Steel Box Detail Sheet for SRT-2® Spool Roll Tarp _____	30
Stainless Steel Box Detail Sheet for SRT-2® Construction Dump Box _____	31
Belly Dump Box Detail Sheet _____	32
Ridge Pole and Load Holes Box Detail Sheet _____	33
Bow Reinforcement Box Detail Sheet _____	34
Drain Holes Box Detail Sheet _____	35

# ELECTRIC CONVERSION KITS

SRT-2® Electric Spool Roll Tarp



ROLTEC® Electric Tarp Conversion



ROLTEC™ Electric Hopper Conversion



## WHY CHOOSE ELECTRIC?

### ELECTRIC IS THE EASY, CLEAN AND SAFE WAY TO HAUL MORE LOADS IN A DAY!

- Increases safety and efficiency by operating from the cab.
- Easy for anyone to use with the push button operation.
- Saves time while increasing productivity.
- An AGRI-COVER™ Switch and Remote Control provides completely integrated system.
- Increases the resale value of your trailer.

CHOOSING YOUR ELECTRIC TARPING SYSTEM	A. ROLTEC Electric Conversion - Front and Rear Spring Arm	B. ROLTEC Electric Conversion - Front Spring Arm w/ Rear Cable Return	C. SRT-2 Electric Conversion	D. EZ-LOC Electric Conversion w/ Front Cable Return	E. Side Locking Electric Conversion w/ Front Cable Return
Grain Trailer 25'-40'	Best	-	-	Good	Good
Grain Trailer 41'-53'	Best	-	-	-	-
Grain Trailer w/ Rear Discharge	-	Best	-	-	-
Pup Trailer	Best	-	Better	Good	Good
Farm Box	-	-	Best	Better	Good
Grain Cart	-	-	Best	-	-
Seed Tender Trailer	-	-	Best	Better	Good

Good, Better, Best are recommendations based on box applications.

**A. ROLTEC® ELECTRIC CONVERSION - FRONT AND REAR SPRING ARM:** Single motor dual spring arm electric conversion, this system uses front and rear spring arms to convert both 2" steel and 2" aluminum roll tarps into an electric system on trailers up to 53'.

**B. ROLTEC® ELECTRIC CONVERSION - FRONT SPRING ARM WITH REAR CABLE RETURN:** Single spring arm electric conversion kit designed specifically for grain trailers with a rear discharge. This system uses a rear cable return system combined with a front spring arm for grain trailers up to 53'.

**C. SRT-2® ELECTRIC CONVERSION:** Slim single motor arm system designed to fit between the cab and the box of a farm truck, converts a manual SRT-2® Spool Roll Tarp to an electric system using the existing tarps dual, in the tube torsion springs.

**D. EZ-LOC® ELECTRIC CONVERSION WITH FRONT CABLE RETURN:** Single motor arm system with front cable return and rear bungee return, converts your 2" aluminum roll tube to an electric tarping system up to 40'.

**E. SIDE LOCKING ELECTRIC CONVERSION WITH FRONT CABLE RETURN:** Single motor arm system with front cable return and rear bungee return, converts your 2" steel roll tube to an electric tarping system up to 40'.

## WHY CHOOSE WIRELESS?

Avoid tarp damage. Stay in control of your system.

### AGRI-COVER™ SWITCH CONTROL AND REMOTE

- Remote controls 99 devices from more than 100 ft. away or from the comfort of your cab.
- Remote shuts off after three minutes of inactivity.
- Remote and receiver come pre-programmed and are easy to re-program.
- Remote uses an A23 battery.
- Built-in overload protection.
- Receiver complies with IP 66 dust and water standards.
- Prewired with simple connectors, no crimping.
- Corrosion resistant mounting hardware.
- Glove friendly toggle switch.
- Tethered switch with 6 ft. lead available (for wireless box).
- Made in the USA.

AGRI-COVER™ SWITCH CONTROL also available



### AGRI-COVER SWITCH CONTROL AND REMOTE

Part #	Description	PRICE
4000703	AGRI-COVER Switch and Remote Control Kit	\$610.00 ea.
4000540	AGRI-COVER Switch Control	\$300.00 ea.
4000711	AGRI-COVER Remote Control	\$110.00 ea.
*4000708	Tethered Switch (with installation hardware)	\$125.00 ea.

\*Tethered switch only compatible with Wireless Switch Control Receiver.

# ROLTEC® ELECTRIC TARP CONVERSION KITS

Converts 2" roll tubes to an electric tarping system on trailers up to 53 ft.

- Motor controls the tension of the tarp, when heaped loads settle, touch the switch to tighten the tarp.
- Worm gears create an instant, positive lock with no backing off for a tighter fitting, longer lasting tarp.
- Rotating and telescoping motor mount allows roll tube to rise and flex over heaped loads, reducing stress on the drive components and pivot arm.
- 4 springs create positive return tension when closing the tarp system, no elbows or joints to break.
- Sturdy, lightweight, universal mounting bracket.
- Manual override, simply remove one pin to operate manually, the motor stays secured to roll tube.



<b>ROLTEC ELECTRIC CONVERSION - FRONT AND REAR SPRING ARM</b>		
Switch and Remote Control		
Part #	Description	PRICE
80245	ROLTEC Electric Tarp Conversion - Switch and Remote Control, Semi Trailer (for ROLTEC Tarp Systems w/ 2" steel tube, front & rear spring arm)	\$2,089.00 ea.
80255	ROLTEC Electric Tarp Conversion - Switch and Remote Control, Semi Trailer (for EZ-LOC Tarp Systems w/ 2" aluminum tube, front & rear spring arm)	\$2,089.00 ea.
Switch Control		
90084	ROLTEC Electric Tarp Conversion - Switch Control, Semi Trailer (for ROLTEC Tarp Systems w/ 2" steel tube)	\$1,979.00 ea.
90086	ROLTEC Electric Tarp Conversion - Switch Control, Semi Trailer (for EZ-LOC Tarp Systems w/ 2" aluminum tube)	\$1,979.00 ea.
Cab Operated		
70900	ROLTEC Electric Tarp Conversion - Cab Operated, Semi Trailer (for ROLTEC Tarp Systems w/ 2" steel tube)	\$1,639.00 ea.
70910	ROLTEC Electric Tarp Conversion - Cab Operated, Semi Trailer (for EZ-LOC Tarp Systems w/ 2" aluminum tube)	\$1,639.00 ea.

<b>ROLTEC ELECTRIC CONVERSION - FRONT SPRING ARM W/ REAR CABLE RETURN</b>		
Switch and Remote Control		
Part #	Description	PRICE
80265	ROLTEC Electric Tarp Conversion w/ Rear Spring Box Return - Switch and Remote Control, Semi Trailer (for ROLTEC Tarp Systems w/ 2" steel tube)	\$1,899.00 ea.
80275	ROLTEC Electric Tarp Conversion w/ Rear Spring Box Return - Switch and Remote Control, Semi Trailer (for EZ-LOC Tarp Systems w/ 2" aluminum tube)	\$1,899.00 ea.
Switch Control		
90087	ROLTEC Electric Tarp Conversion w/ Rear Spring Box Return - Switch Control, Semi Trailer (for ROLTEC Tarp Systems w/ 2" steel tube)	\$1,789.00 ea.
90089	ROLTEC Electric Tarp Conversion w/ Rear Spring Box Return - Switch Control, Semi Trailer (for EZ-LOC Tarp Systems w/ 2" aluminum tube)	\$1,789.00 ea.
Cab Operated		
80120	ROLTEC Electric Tarp Conversion w/ Rear Spring Box Return - Cab Operated, Semi Trailer (for ROLTEC Tarp Systems w/ 2" steel tube)	\$1,449.00 ea.
80140	ROLTEC Electric Tarp Conversion w/ Rear Spring Box Return - Cab Operated, Semi Trailer (for EZ-LOC Tarp Systems w/ 2" aluminum tube)	\$1,449.00 ea.

<b>ACCESSORIES FOR ELECTRIC KITS</b>		
Part #	Description	PRICE
80188	Heavy Gauge Wire Splice Kit (2 connectors)	\$52.00 ea.
70584	Bracket, Slant	\$19.50 ea.
60768	Wire 4 Ga. 2 Strand (price per lin. ft.)	\$6.00 ea.

# ROLTEC™ ELECTRIC HOPPER CONVERSION KITS

- Worm gear motor and chain drive gear box provide optimal torque needed to open and close the hopper.
- Worm gears create an instant, positive lock. No brakes or limit switch to fail.
- Reliable chain drive system with corrosion resistant, durable metal housing.
- High clearance design installs above factory hardware with a stabilizing arm for a three point mounting system.
- Split sprocket technology eliminates the need to cut the drive shaft in most cases.
- Manual override, if needed.



**ELECTRIC CONVERSIONS**

ROLTEC ELECTRIC HOPPER CONVERSION		
Switch and Remote Control		
Part #	Description	PRICE
80260	ROLTEC Electric Hopper Conversion - Switch and Remote Control (single hopper trailer)	\$1,672.00 ea.
80270	ROLTEC Electric Hopper Conversion - Switch and Remote Control (dual hopper trailer)	\$2,879.00 ea.
80280	ROLTEC Electric Hopper Conversion - Switch and Remote Control (triple hopper trailer)	\$4,000.00 ea.
80290	ROLTEC Electric Hopper Conversion - Switch and Remote Control (quad hopper trailer)	\$5,150.00 ea.
Switch Control		
90101	ROLTEC Electric Hopper Conversion - Switch Control (single hopper trailer)	\$1,562.00 ea.
90102	ROLTEC Electric Hopper Conversion - Switch Control (dual hopper trailer)	\$2,769.00 ea.
90103	ROLTEC Electric Hopper Conversion - Switch Control (triple hopper trailer)	\$3,890.00 ea.
90104	ROLTEC Electric Hopper Conversion - Switch Control (quad hopper trailer)	\$5,040.00 ea.
Trailers without an electric tarp will need to order the following parts		
90144	Tractor Wiring Kit 4 Ga. (includes breaker, dual pole connector & 20' of wire)	\$198.00 ea.
40918	Dual Pole Connector Socket & Plug Kit (200 Amp) (includes bolts, washers, nuts, terminals & heat shrink tubes)	\$92.00 ea.
60768	Wire 4 Ga. 2 Strand (price per lin. ft.)	\$6.00 ea.
80094	1" Round Shaft Conversion	\$21.00 ea.

\*ROLTEC™ Electric Hopper Conversion is designed for 1" round drive shafts, adapter available for other shaft sizes part #80094.

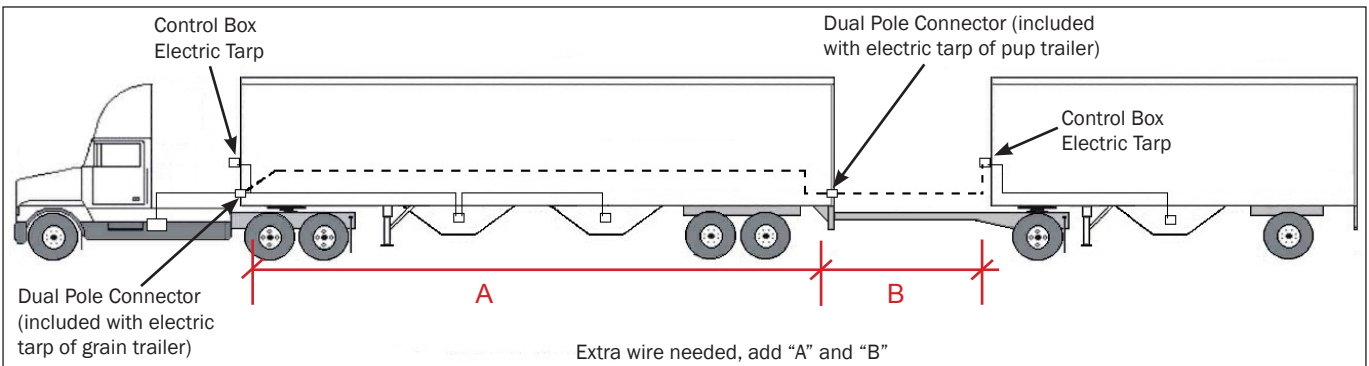

See page 27 for more detail

# SEMI TRAILERS

EZ-LOC® Roll-Up Tarp



AUTOLOCK® Electric Tarp (front)



AUTOLOCK® Electric Tarp (back)



# SEMI TRAILER TARP SYSTEMS

## AUTOLOCK® ELECTRIC TARP

- Motor is constructed of corrosion resistant, durable metal housing.
- Unique DUAL DRIVE™ System has a wind resistant design featuring a strong synthetic cable and tension spring that work together to provide a powerful front and rear drive to cover your load.
- Rotating and telescoping motor mount allows roll tube to rise and flex over heaped loads, reducing stress on the drive components and pivot arm.
- Extra durable 3" aluminum roll tube is strong, yet lightweight offering a faster and straighter roll.

## EZ-LOC® ROLL-UP TARP

- 2" aluminum roll tube is rust resistant and strong, yet lightweight to minimize tarp wear.
- Rope channel design creates uniform tarp tension for a better fitting and longer lasting tarp.
- Custom end caps with crimped standing seam is self sealing and flexible, no welds to break.
- Premium commercial grade, UV resistant vinyl remains flexible at -40° F.
- Quick release aluminum tarp stops.
- Heavy duty zinc plated U-joint with 21 splines for fine tuning tarp tension.

## ROLTEC® SIDE LOCKING TARP

- Custom end caps with crimped standing seam is self sealing and flexible, no welds to break.
- Premium commercial grade, UV resistant vinyl remains flexible at -40° F.
- Front bungee return system assists the operator with pulling action for easier operation when closing the tarp.
- Quick release aluminum tarp stops.
- Heavy duty zinc plated U-joint with 21 splines for fine tuning tarp tension.
- Adjustable crank handle with pinless retainer for an easy in, easy out system that saves time.

## FEATURE COMPARISON CHART

		AUTOLOCK	EZ-LOC	ROLTEC
End Caps	Material	Galvanized up to 102" wide box Optional - Aluminum up to 102" wide box		
	Profile	14" deep, with bracket attachment 7" or 12" rise available dependent on box width	14" deep, bolt through attachment 7" or 12" rise available dependent on box width	10" deep, bolt through attachment 7" or 12" rise available dependent on box width
	All end caps have crimped built-in wind deflector and support bow			
	Weather Seal	Included	None	
Bows		Not included		
Ridge Strap(s)		2 ridge straps	1 ridge strap	
Tarp Stops		Aluminum quick release with integrated set screw on front and rear		
Roll Tube		3" aluminum	2" aluminum	2" galvanized steel
Tension System		Drive line and tension spring set at install on both ends, no adjustment needed	21 spline adjustable zinc plated U-joint crank handle	
Front and Rear Roll Return		Integrated in the tensioning system	Front bungee return Optional - Front spring return Front or rear cable return Rear bungee return	
Tarp Attachment		Rope in channel		Tarp tube clips
Tarp Construction		Premium commercial grade, UV resistant 18 oz. vinyl fabric Optional - 22 oz. vinyl fabric		
Tarp Colors		Black, white, gray, blue, red, orange, green, yellow and brown Optional - Multi-colored or 22 oz. black, white, gray, blue and red		
Electric Kit		Included	Optional	

# SEMI TRAILER KIT PRICING

## SEMI TRAILERS

### AUTOLOCK® ELECTRIC TARP

- High output electric motor
- Unique DUAL DRIVE™ System
- Stainless steel rotating and telescoping motor mount
- Extra durable 3" aluminum roll tube
- 14" deep, 7" rise galvanized end caps (front side mounted, rear top mounted)\*\*
- Quick release aluminum tarp stops
- 18 oz. vinyl
- No arm to obstruct the back of the trailer
- 2 ridge straps

### EZ-LOC® ROLL-UP TARP

- 2" aluminum roll tube
- 14" deep, 7" rise galvanized end caps (front side mounted, rear top mounted)\*\*
- Heavy duty 21 spline U-joint
- 18 oz. vinyl
- Quick release aluminum tarp stops
- Adjustable crank handle with pinless retainer
- Front bungee return system
- 1 ridge strap

### ROLTEC® SIDE LOCKING TARP

- 10" deep, 7" rise galvanized end caps (front side mounted, rear top mounted)\*\*
- 18 oz. vinyl
- Quick release aluminum tarp stops
- Heavy duty 21 spline U-joint
- Adjustable crank handle with pinless retainer
- Front bungee return system
- 1 ridge strap
- 2" steel roll tube

STANDARD TARP KIT PRICING FOR SEMI TRAILERS							For pricing round box length up to nearest foot.
Box Length	AUTOLOCK		EZ-LOC		ROLTEC		
Up to 96" Wide	Bows*	PRICE	Bows*	PRICE	Bows*	PRICE	
18'	3	\$2,630.75	-	-	-	-	
19'	4	\$2,676.25	-	-	-	-	
20'	4	\$2,705.00	-	-	-	-	
21'	4	\$2,733.50	-	-	-	-	
22'	4	\$2,760.75	-	-	-	-	
23'	5	\$2,789.50	-	-	-	-	
24'	5	\$2,818.00	-	-	-	-	
25'	5	\$2,880.50	5	\$1,185.75	5	\$1,072.50	
26'	5	\$2,910.25	5	\$1,207.75	5	\$1,092.00	
27'	6	\$2,937.50	6	\$1,230.00	6	\$1,119.50	
28'	6	\$2,966.25	6	\$1,250.75	6	\$1,148.00	
29'	6	\$2,994.75	6	\$1,272.75	6	\$1,166.25	
30'	6	\$3,023.50	6	\$1,295.00	6	\$1,185.75	
31'	7	\$3,052.00	7	\$1,317.00	7	\$1,205.25	
32'	7	\$3,080.50	7	\$1,339.00	7	\$1,224.75	
33'	7	\$3,109.25	7	\$1,360.00	7	\$1,244.25	
34'	8	\$3,136.50	8	\$1,382.00	8	\$1,263.75	
35'	8	\$3,165.00	8	\$1,404.00	8	\$1,292.25	
36'	8	\$3,193.75	8	\$1,426.25	8	\$1,318.25	
37'	8	\$3,239.25	8	\$1,473.00	8	\$1,337.75	
38'	8	\$3,267.75	8	\$1,495.00	8	\$1,357.25	
39'	9	\$3,296.50	9	\$1,517.25	9	\$1,376.75	
40'	9	\$3,325.00	9	\$1,539.25	9	\$1,396.25	
41'	9	\$3,353.50	9	\$1,560.00	9	\$1,415.75	
42'	9	\$3,381.00	9	\$1,582.25	9	\$1,435.25	
43'	9	\$3,410.75	9	\$1,604.25	9	\$1,453.50	
44'	10	\$3,438.00	10	\$1,626.50	10	\$1,482.00	
45'	10	\$3,466.75	10	\$1,648.50	10	\$1,509.50	
46'	10	\$3,495.25	10	\$1,669.25	10	\$1,529.00	
47'	11	\$3,524.00	11	\$1,691.50	11	\$1,547.00	
48'	11	\$3,551.25	11	\$1,713.50	11	\$1,568.00	
49'	11	\$3,579.75	11	\$1,735.50	11	\$1,587.50	
50'	11	\$3,608.50	11	\$1,757.75	11	\$1,605.50	
51'	12	\$3,637.00	12	\$1,778.50	12	\$1,635.50	
52'	12	\$3,682.50	12	\$1,818.75	12	\$1,661.50	
53'	12	\$3,711.00	12	\$1,841.00	12	\$1,681.00	
54'	12	\$3,739.75	-	-	-	-	
55'	12	\$3,768.25	-	-	-	-	
56'	12	\$3,797.00	-	-	-	-	

\*Bows not included. Table above gives suggested bow quantities to order if needed.

\*\*Some trailers may require OEM specific radius caps. Call for quote.

# SEMI TRAILER OPTIONS AND ACCESSORIES

**SEMI TRAILERS**

OPTIONS FOR SEMI TRAILER BOX TARP KITS		AUTOLOCK	EZ-LOC	ROLTEC	
END CAP OPTIONS	Options	Add / Deduct	PRICE	PRICE	PRICE
	Boxes 96-1/2" up to 102" Wide Option	Add	\$87.25	\$87.25	\$87.25
	End Caps Tall 12" Rise Galvanized (pair)	Add	\$45.50	\$45.50	\$45.50
	End Cap 14" Deep Option, Galvanized (pair) (front side mounted, rear top mounted) ADD TO COST OF 7" STANDARD OR 12" GALVANIZED OPTION ABOVE	Add	Standard	Standard	\$25.00
	End Caps Standard 7" Rise Aluminum (pair) (front and rear side mounted)	Add	\$82.00	\$82.00	\$82.00
	End Caps Tall 12" Rise Aluminum (pair) (front and rear side mounted)	Add	\$91.00	\$91.00	\$91.00
	End Cap 14" Deep Option, Aluminum (pair) (front and rear side mounted) ADD TO COST OF 7" OR 12" ALUMINUM OPTION ABOVE	Add	-	-	\$35.50
	End Cap Bolt-On Brackets (each)	Add	Standard	\$22.25	NA
	End Cap, "Z" Bracket	Add	\$22.25	\$22.25	\$22.25
	No End Caps (pair)	Deduct	NA	-\$88.50	-\$83.25
	End Cap (Front), Aluminum w/ Filler and Full Wrap Radius (each)	Add	\$140.50	\$140.50	\$140.50
	End Cap (Front and Rear), Aluminum w/ Square Wrap (each)	Add	\$50.75	\$50.75	\$50.75
	Universal Front Galvanized w/ Metal Filler (each)	Add	\$49.50	\$49.50	\$49.50
	Universal Front Aluminum w/ Metal Filler (each)	Add	\$65.00	\$65.00	\$65.00
	Universal Front Stainless Steel w/ Metal Filler (each)	Add	\$131.50	\$131.50	\$131.50
	Rear Fabric Filler (each)	Add	\$114.50	\$114.50	\$114.50
MISC. OPTIONS	Bolt on Tarp Stop	Deduct	NA	-\$8.00	-\$8.00
	Standard Bows (each)	Add	\$35.25	\$35.25	\$35.25
	HD Aluminum Bows (each)	Add	\$87.25	\$87.25	\$87.25
	Ridge Strap (each) (for kits 25-53')	Add	(2 included)	\$39.00	\$39.00
	No Ridge Strap (each)	Deduct	-\$10.50	-\$10.50	-\$10.50
RETURN OPTIONS	Rear Bungee Roll Return (for rear of hand crank systems) Part # 50753	Add	NA	\$50.75	\$50.75
	Cable Return, Non-Drive Side	Add	NA	\$105.50	\$105.50
	Cable Return, Drive Side	Add	NA	\$151.00	\$151.00
	Optional Front Spring Return (each) Part # 80025 for EZ-LOC, Part # 80020 for Steel Roll Tube	Add	NA	\$73.00	\$73.00
TARP WEIGHT	18 oz. Tarp in Multi-Color (per kit)	Add	\$39.00	\$39.00	\$39.00
	22 oz. Tarp Fabric in Black, White, Gray, Blue, Red (per lin. ft.)	Add	NA	\$1.36	\$1.36
HANDLE OPTIONS	Folding Crank Handle	Add	NA	\$106.75	\$106.75
	Handle Holder, w/ Pinned Offset Retainer (includes 2 retainers)	No Charge	NA	No Charge	
	Handle Holder, w/ Pinless Offset Retainer (includes 2 retainers)	Add	NA	\$17.00	\$17.00
ELECTRIC OPTIONS	Electric Conversion Kit w/ Cable Return for EZ-LOC and ROLTEC Tarp Systems, Semi Trailer (cab operated) (upgrade)	Add	NA	\$910.00	\$910.00
	Wireless System w/ Switch and Remote Control Upgrade (add to cost of Electric Kit)	Add	\$450.00	\$450.00	\$450.00
	Switch Control Electric System Upgrade (add to cost of Electric Kit)	Add	\$340.00	\$340.00	\$340.00
	ROLTEC Electric Tarp Conversion for new or existing EZ-LOC and ROLTEC Tarp Systems	Add	NA	See Page 6 for Details	
	ROLTEC Electric Tarp Conversion w/ Cable Return for existing EZ-LOC and ROLTEC Tarp Systems	Add	NA	See Page 6 for Details	
<b>ACCESSORIES</b>					
Part #	Description	PRICE			
70090	AUTOLOCK Manual Override Kit	\$114.50 ea.			
80388	Tarp Safety Cords (2 pack)	\$82.95 ea.			
80055	Bow Cover	\$7.85 ea.			
60691	Deflector, Roll Tube w/ 2 Bolts	\$8.79 ea.			
90613	Rolltection Tarp Safety Cords (2 pack)	\$51.95 ea.			

# FARM TRUCKS, SEED TENDERS AND GRAIN CARTS

EZ-LOC® Roll-Up Tarp



ROLTEC® Side Locking Tarp



SRT-2® Spool Roll Tarp



# FARM TRUCK, SEED TENDER AND GRAIN CART TARP SYSTEMS

## SRT-2® SPOOL ROLL TARP

- Spring loaded spools provide continuous tarp tension while rolling and unrolling, even in windy conditions.
- Tension ratchets allow for fine tuning tarp tension during initial install, no need to adjust.
- Extra durable 3" aluminum roll tube is strong, yet lightweight offering a faster and straighter roll.
- Rope channel design creates uniform tarp tension for a better fitting and longer lasting tarp.
- Telescoping crank handle with flex drive system rolls and unrolls the tarp at many angles with ease.

## EZ-LOC® ROLL-UP TARP

- 2" aluminum roll tube is rust resistant and strong, yet lightweight to minimize tarp wear.
- Rope channel design creates uniform tarp tension for a better fitting and longer lasting tarp.
- Custom end caps with crimped standing seam is self sealing and flexible, no welds to break.
- Premium commercial grade, UV resistant vinyl remains flexible at -40° F.
- Quick release aluminum tarp stops.
- Heavy duty zinc plated U-joint with 21 splines for fine tuning tarp tension.

## ROLTEC® SIDE LOCKING TARP

- Custom end caps with crimped standing seam is self sealing and flexible, no welds to break.
- Premium commercial grade, UV resistant vinyl remains flexible at -40° F.
- Front bungee return system assists the operator with pulling action for easier operation when closing the tarp.
- Quick release aluminum tarp stops.
- Heavy duty zinc plated U-joint with 21 splines for fine tuning tarp tension.
- Adjustable crank handle with pinless retainer for an easy in, easy out system that saves time.

## FEATURE COMPARISON CHART

		SRT-2	EZ-LOC	ROLTEC
End Caps	Material	Galvanized up to 144" wide box Optional - Aluminum less than or equal to 118" box width	Galvanized up to 168" wide box Optional - Aluminum less than or equal to 118" box width	
	Profile	14" deep, with bracket attachment 7" or 12" rise available	14" deep, bolt through attachment 7" or 12" rise available	10" deep, bolt through attachment 7" or 12" rise available
		All end caps have crimped built-in wind deflector and support bow		
	Weather Seal	Included	None	
	Spliced (2 pieces)	On box widths greater than 118"		
Galvanized Bows	Included on farm boxes and grain carts Heavy duty square bows on grain carts greater than 118" in box width			
Ridge Strap(s)	1 ridge strap			
Tarp Stops	Aluminum quick release with integrated set screw on front and rear			
Roll Tube	3" aluminum	2" aluminum	2" galvanized steel	
Tension System	Spring loaded spool, set at install with cable and ratchet on both ends, no adjustment needed	21 spline adjustable zinc plated U-joint crank handle		
Front and Rear Roll Return	Integrated in the tensioning system	Front bungee return Optional - Front spring return Front or rear cable return Rear bungee return		
Tarp Attachment	Rope in channel		Tarp tube clips	
Tarp Construction	Premium commercial grade, UV resistant 18 oz. vinyl fabric Optional - 22 oz. vinyl fabric for EZ-LOC and ROLTEC			
Tarp Colors	Black, white, gray, blue, red, orange, green, yellow and brown Optional - Multi-colored or 22 oz. black, white, gray, blue and red			
Electric Kit	Optional			

## FARM TRUCK, SEED TENDER AND GRAIN CART FEATURES AND BENEFITS

### SRT-2® SPOOL ROLL TARP

- Spring loaded spools
- Tension ratchets
- Extra durable 3" aluminum roll tube
- Telescoping crank handle with flex drive system
- 14" deep, 7" rise galvanized end caps\*
- Quick release aluminum tarp stops
- 18 oz. vinyl
- Galvanized bows
- 1 ridge strap

### EZ-LOC® ROLL-UP TARP

- 2" aluminum roll tube
- 14" deep, 7" rise galvanized end caps\*
- Heavy duty 21 spline U-joint
- 18 oz. vinyl
- Quick release aluminum tarp stops
- Adjustable crank handle with pinless retainer
- Front bungee return system
- 1 ridge strap

### ROLTEC® SIDE LOCKING TARP

- 10" deep, 7" rise galvanized end caps\*
- 18 oz. vinyl
- Quick release aluminum tarp stops
- Heavy duty 21 spline U-joint
- Adjustable crank handle with pinless retainer
- Front bungee return system
- 1 ridge strap
- 2" steel roll tube

\* Farm truck and seed tender end caps are front side mounted and rear top mounted. Grain cart end caps are 12" rise standard and are front and rear side mounted.

## FARM TRUCK AND SEED TENDER KIT PRICING

STANDARD TARP KIT PRICING FOR FARM TRUCKS AND SEED TENDERS							For pricing round box length up to nearest foot.	
Box length in ft.		SRT-2		EZ-LOC		ROLTEC		
Up to 96" wide	Bows	PRICE	Bows	PRICE	Bows	PRICE		
8'	2	\$1,016.75	2	\$821.75	2	\$704.75		
9'	2	\$1,041.50	2	\$843.75	2	\$721.50		
10'	2	\$1,064.75	2	\$866.00	2	\$746.25		
11'	3	\$1,115.50	2	\$888.00	2	\$772.25		
12'	3	\$1,140.25	2	\$910.00	2	\$789.25		
13'	3	\$1,163.50	2	\$931.00	2	\$807.50		
14'	3	\$1,188.25	2	\$953.00	2	\$824.25		
15'	4	\$1,240.25	3	\$1,003.75	3	\$871.00		
16'	4	\$1,263.75	3	\$1,024.50	3	\$888.00		
17'	4	\$1,287.00	3	\$1,046.50	3	\$906.25		
18'	4	\$1,311.75	3	\$1,068.75	3	\$923.00		
19'	5	\$1,362.50	4	\$1,126.00	4	\$977.75		
20'	5	\$1,387.25	4	\$1,148.00	4	\$1,003.75		
21'	5	\$1,412.00	4	\$1,198.75	4	\$1,020.50		
22'	5	\$1,435.25	4	\$1,211.75	4	\$1,038.75		
23'	6	\$1,486.00	5	\$1,310.50	5	\$1,084.25		
24'	6	\$1,545.75	5	\$1,323.50	5	\$1,102.50		

# FARM TRUCK AND SEED TENDER OPTIONS AND ACCESSORIES

**FARM TRUCKS, SEED TENDERS AND GRAIN CARTS**

OPTIONS FOR FARM TRUCK AND SEED TENDER BOX TARP KITS			SRT-2	EZ-LOC	ROLTEC
END CAP OPTIONS	Options	Add / Deduct	PRICE	PRICE	PRICE
	Boxes 96-1/2" up to 102" Wide Option	Add	\$87.25	\$87.25	\$87.25
	End Caps Tall 12" Rise Galvanized (pair)	Add	\$45.50	\$45.50	\$45.50
	End Cap 14" Deep Option, Galvanized (pair) (front side mounted, rear top mounted) ADD TO COST OF 7" STANDARD OR 12" GALVANIZED OPTION ABOVE	Add	Standard	Standard	\$25.00
	End Caps Standard 7" Rise Aluminum (pair) (front and rear side mounted)	Add	\$82.00	\$82.00	\$82.00
	End Caps Tall 12" Rise Aluminum (pair) (front and rear side mounted)	Add	\$91.00	\$91.00	\$91.00
	End Cap 14" Deep Option, Aluminum (pair) (front and rear side mounted) ADD TO COST OF 7" OR 12" ALUMINUM OPTION ABOVE	Add	-	-	\$35.50
	End Cap Bolt-On Brackets (each)	Add	Standard	\$22.25	NA
	End Cap, "Z" Bracket	Add	\$22.25	\$22.25	\$22.25
	Quick Release End Cap Rear / Top Mount	Add	\$39.00	\$61.25	NA
	Quick Release End Cap Front / Side Mount	Add	\$53.50	\$75.50	NA
	No End Caps (pair)	Deduct	-\$88.50	-\$88.50	-\$83.25
	Universal Front, Galvanized w/ Metal Filler (each)	Add	\$49.50	\$49.50	\$49.50
	Universal Front, Aluminum w/ Metal Filler (each)	Add	\$65.00	\$65.00	\$65.00
	Universal Front, Stainless Steel w/ Metal Filler (each)	Add	\$131.50	\$131.50	\$131.50
	Rear Fabric Filler (each)	Add	\$114.50	\$114.50	\$114.50
	MISC. OPTIONS	Bolt on Tarp Stops (each)	Deduct	NA	-\$8.00
Standard Bows (each)		Add	\$35.25	\$35.25	\$35.25
HD Aluminum Bows (each)		Add	\$62.50	\$62.50	\$62.50
No Bows (each)		Deduct	-\$15.75	-\$15.75	-\$15.75
Ridge Strap (each) (for kits 8-24')		Add	\$23.00	\$23.00	\$23.00
No Ridge Strap (each)		Deduct	-\$10.50	-\$10.50	-\$10.50
RETURN OPTIONS	Rear Bungee Roll Return (for rear of hand crank systems) Part # 50753	Add	NA	\$50.75	\$50.75
	Cable Return, Non-Drive Side	Add	NA	\$105.50	\$105.50
	Cable Return, Drive Side	Add	NA	\$151.00	\$151.00
	Optional Front Spring Return (each) Part # 80025 for EZ-LOC, Part # 80020 for Steel Roll Tube	Add	NA	\$73.00	\$73.00
TARP WEIGHT	18 oz. Tarp in Multi-Color (per kit)	Add	\$39.00	\$39.00	\$39.00
	22 oz. Tarp Fabric in Black, White, Gray, Blue, Red (per lin. ft.)	Add	NA	\$1.36	\$1.36
HANDLE OPTIONS	Folding Crank Handle	Add	NA	\$106.75	\$106.75
	Handle Holder, w/ Pinned Offset Retainer (includes 2 retainers)	No Charge	Standard	No Charge	
	Handle Holder, w/ Pinless Offset Retainer (includes 2 retainers)	Add	NA	\$17.00	\$17.00
ELECTRIC OPTIONS	Electric Conversion Kit w/ Cable Return for EZ-LOC and ROLTEC Tarp Systems (farm box w/ hoist) cab operated (upgrade)	Add	NA	\$970.00	\$970.00
	SRT-2 Electric Conversion Kit (upgrade)	Add	\$715.00	NA	NA
	SRT-2 Electric Conversion Kit (farm truck w/ hoist) cab operated (upgrade)	Add	\$775.00	NA	NA
	Wireless System w/ Switch and Remote Control (add to cost of Electric Kit)	Add	\$450.00	\$450.00	\$450.00
	Switch Control Electric System Upgrade (add to cost of Electric Kit)	Add	\$340.00	\$340.00	\$340.00
<b>ACCESSORIES</b>					
Part #	Description			PRICE	
60691	Deflector, Roll Tube w/ 2 Bolts			\$8.79 ea.	
80388	Tarp Safety Cords (2 pack)			\$82.95 ea.	
80055	Bow Cover			\$7.85 ea.	
90613	Roltection Tarp Safety Cords (2 pack)			\$51.95 ea.	

# GRAIN CART KIT PRICING

FARM TRUCKS, SEED TENDERS AND GRAIN CARTS

STANDARD TARP KIT PRICING FOR GRAIN CARTS				For pricing round box length up to nearest foot.		
Box Length in ft.	SRT-2	EZ-LOC	ROLTEC	SRT-2	EZ-LOC	ROLTEC
	Up to 96" Box Width			Up to 102" Box Width		
8'	\$1,062.25	\$867.25	\$750.25	\$1,149.50	\$954.50	\$837.50
9'	\$1,087.00	\$889.25	\$767.00	\$1,174.25	\$976.50	\$854.25
10'	\$1,110.25	\$911.50	\$791.75	\$1,197.50	\$1,026.25	\$879.00
11'	\$1,161.00	\$933.50	\$817.75	\$1,248.25	\$1,048.25	\$905.00
12'	\$1,185.75	\$955.50	\$834.75	\$1,273.00	\$1,070.25	\$922.00
13'	\$1,209.00	\$976.50	\$853.00	\$1,296.25	\$1,091.25	\$940.25
14'	\$1,233.75	\$998.50	\$869.75	\$1,321.00	\$1,140.75	\$957.00
15'	\$1,285.75	\$1,049.25	\$916.50	\$1,373.00	\$1,164.00	\$1,003.75
16'	\$1,309.25	\$1,070.00	\$933.50	\$1,396.50	\$1,184.75	\$1,020.75
17'	\$1,332.50	\$1,092.00	\$951.75	\$1,419.75	\$1,206.75	\$1,039.00
18'	\$1,357.25	\$1,114.25	\$968.50	\$1,444.50	\$1,256.50	\$1,055.75
19'	\$1,408.00	\$1,171.50	\$1,023.25	\$1,495.25	\$1,286.25	\$1,110.50
20'	\$1,432.75	\$1,193.50	\$1,049.25	\$1,520.00	\$1,308.25	\$1,136.50
21'	\$1,457.50	\$1,244.25	\$1,066.00	\$1,544.75	\$1,359.00	\$1,153.25
22'	\$1,480.75	\$1,257.25	\$1,084.25	\$1,568.00	\$1,399.50	\$1,171.50
23'	\$1,531.50	\$1,356.00	\$1,129.75	\$1,618.75	\$1,470.75	\$1,217.00
24'	\$1,591.25	\$1,369.00	\$1,148.00	\$1,678.50	\$1,483.75	\$1,235.25
25'	-	-	-	-	-	-
26'	-	-	-	-	-	-
27'	-	-	-	-	-	-
28'	-	-	-	-	-	-
29'	-	-	-	-	-	-
30'	-	-	-	-	-	-

## GRAIN CART OPTIONS AND ACCESSORIES

OPTIONS FOR GRAIN CARTS AND GRAIN WAGON BOXES			SRT-2	EZ-LOC	ROLTEC
		Add / deduct	PRICE	PRICE	PRICE
END CAP OPTIONS	Options	Add / deduct	PRICE	PRICE	PRICE
	End Cap Bolt-On Brackets (each)	Add	Standard	\$22.25	NA
	Quick Release End Cap Rear / Top Mount	Add	\$39.00	\$61.25	NA
	Quick Release End Cap Front / Side Mount	Add	\$53.50	\$75.50	NA
	No End Caps (pair)	Deduct	-\$88.50	-\$88.50	-\$83.25
	End Cap 14" Deep Option, Galvanized (pair) (front side mounted and rear side mounted)	Add	NA	NA	\$25.00
	Kinze End Cap Upgrade (900, 1100, 1300, 1500)	Add	\$421.25	\$447.25	\$472.25
MISC. OPTIONS	Bolt on Tarp Stop (each)	Deduct	NA	-\$8.00	-\$8.00
	Bows (each)	Add	\$35.25	\$35.25	\$35.25
	Square Bows (each) (for kits above 118" wide)	Add	\$62.25	\$62.25	\$62.25
	HD Aluminum Bows (each)	Add	\$113.25	\$113.25	\$113.25
	Ridge Strap (each) (for kits from 8-24')	Add	\$23.00	\$23.00	\$23.00
	Ridge Strap (each) (for kits from 25-30')	Add	\$39.00	\$39.00	\$39.00
	No Ridge Strap (each)	Deduct	-\$10.50	-\$10.50	-\$10.50
	Rear Bungee Roll Return (for rear of hand crank systems) Part # 50753	Add	NA	\$50.75	\$50.75
	Wide Cable Return, Non-Drive Side	Add	NA	\$156.00	\$156.00
	Wide Spring Return Part # 90135 for EZ-LOC, Part # 90125 for Steel Roll Tube	Add	NA	\$105.50	\$105.50
TARP WEIGHT	18 oz. Tarp in Multi-Color (per kit)	Add	\$39.00	\$39.00	\$39.00
	22 oz. Tarp Fabric in Black, White, Gray, Blue, Red (per lin. ft.)	Add	NA	\$1.36	\$1.36
ELECTRIC OPTIONS	SRT-2 Electric Conversion Kit (grain cart up to 144" wide) cab operated (upgrade)	Add	\$814.00	NA	NA
	Wireless System w/ Switch and Remote Control (Add to cost of Electric Kit)	Add	\$450.00	\$450.00	\$450.00
	Switch Control Electric System Upgrade (Add to cost of Electric Kit)	Add	\$340.00	\$340.00	\$340.00

STANDARD TARP KIT PRICING FOR GRAIN CARTS						For pricing round box length up to nearest foot.		
	SRT-2	EZ-LOC	ROLTEC	SRT-2	EZ-LOC	ROLTEC	EZ-LOC	ROLTEC
Box Length in ft.	Up to 118" Box Width			Up to 144" Box Width			Up to 168" Box Width	
8'	\$1,198.75	-	-	\$1,288.50	-	-	-	-
9'	\$1,230.00	-	-	\$1,322.25	-	-	-	-
10'	\$1,263.75	\$1,222.00	\$985.50	\$1,354.75	\$1,321.00	\$1,045.25	-	-
11'	\$1,341.75	\$1,248.00	\$1,014.00	\$1,432.75	\$1,347.00	\$1,072.50	-	-
12'	\$1,375.50	\$1,274.00	\$1,087.00	\$1,465.25	\$1,373.00	\$1,145.50	-	-
13'	\$1,406.75	\$1,301.50	\$1,106.50	\$1,499.00	\$1,399.00	\$1,165.00	-	-
14'	\$1,440.50	\$1,373.00	\$1,128.50	\$1,531.50	\$1,471.75	\$1,185.75	-	-
15'	\$1,519.75	\$1,399.00	\$1,146.75	\$1,609.50	\$1,497.75	\$1,206.50	-	-
16'	\$1,552.25	\$1,425.00	\$1,218.25	\$1,642.00	\$1,523.75	\$1,278.00	\$1,622.50	\$1,337.75
17'	\$1,584.75	\$1,451.00	\$1,239.00	\$1,675.75	\$1,579.50	\$1,300.00	\$1,707.00	\$1,358.50
18'	\$1,617.25	\$1,523.75	\$1,258.50	\$1,708.25	\$1,651.00	\$1,318.25	\$1,777.25	\$1,380.75
19'	\$1,696.50	\$1,581.00	\$1,289.75	\$1,786.25	\$1,718.75	\$1,348.25	\$1,856.50	\$1,409.25
20'	\$1,729.00	\$1,607.00	\$1,366.50	\$1,818.75	\$1,744.75	\$1,427.50	\$1,882.50	\$1,488.50
21'	\$1,761.50	\$1,659.00	\$1,386.00	\$1,852.50	\$1,796.75	\$1,448.25	\$1,933.25	\$1,509.50
22'	\$1,794.00	\$1,728.00	\$1,406.75	\$1,885.00	\$1,867.00	\$1,470.50	\$2,003.50	\$1,531.50
23'	\$1,873.50	\$1,816.25	\$1,427.50	\$1,963.00	\$1,965.75	\$1,490.00	\$2,114.00	\$1,552.25
24'	\$1,941.00	\$1,839.50	\$1,499.00	\$2,030.75	\$1,989.00	\$1,560.00	\$2,136.00	\$1,623.75
25'	-	\$1,881.25	\$1,519.75	\$2,108.75	\$2,030.75	\$1,582.25	\$2,179.00	\$1,643.25
26'	-	\$1,907.25	\$1,539.25	\$2,141.25	\$2,056.75	\$1,603.00	\$2,205.00	\$1,665.50
27'	-	\$1,933.25	\$1,568.00	-	\$2,082.75	\$1,630.25	\$2,231.00	\$1,692.75
28'	-	\$2,006.00	\$1,648.50	-	\$2,155.50	\$1,711.00	\$2,302.50	\$1,773.25
29'	-	\$2,032.00	\$1,669.25	-	\$2,181.50	\$1,730.50	\$2,329.75	\$1,792.75
30'	-	\$2,058.00	\$1,688.75	-	\$2,207.50	\$1,752.50	\$2,355.75	\$1,813.50

ACCESSORIES		
Part #	Description	PRICE
70992	Offset Base Bracket Kit (hardware included)	\$10.50 ea.

TARP STOPS FOR GRAIN CARTS					
SRT-2		EZ-LOC		ROLTEC	
Box Length	Tarp Stop Quantity	Box Length	Tarp Stop Quantity	Box Length	Tarp Stop Quantity
8-18'	3	8-18'	3	8-10'	2
19-26'	4	19-24'	4	11-18'	3
-	-	25-30'	6	19-26'	4
-	-	-	-	27-30'	5

BOWS FOR KITS UP TO 102"						BOWS FOR KITS OVER 102"					
SRT-2		EZ-LOC		ROLTEC		SRT-2		EZ-LOC		ROLTEC	
Size / LGT	# of Bows	Size / LGT	# of Bows	Size / LGT	# of Bows	Size / LGT	# of Bows	Size / LGT	# of Bows	Size / LGT	# of Bows
8-10'	2	8-14'	2	8-14'	2	8-10'	2	8-9'	2	8-9'	2
11-14'	3	15-18'	3	15-18'	3	11-14'	3	10-13'	3	10-13'	3
15-18'	4	19-22'	4	19-22'	4	15-18'	4	14-17'	4	14-17'	4
19-22'	5	23-24'	5	23-24'	5	19-22'	5	18-21'	5	18-21'	5
23-24'	6	-	-	-	-	23-26'	6	22-27'	6	22-27'	6
						-	-	28-30'	7	28-30'	7

# FERTILIZER, CONSTRUCTION AND STAINLESS STEEL



SRT-2® Electric Spool Roll Tarp



AUTOLOCK® Electric Tarp (front)



AUTOLOCK® Electric Tarp (back)

# FERTILIZER AND STAINLESS STEEL TARP SYSTEMS

## SRT-2® SPOOL ROLL TARP

for boxes up to 24' long

- Spring loaded spools provide continuous tarp tension while rolling and unrolling, even in windy conditions.
- Tension ratchets allow for fine tuning tarp tension during initial install, no need to adjust.
- Extra durable 3" aluminum roll tube is strong, yet lightweight offering a faster and straighter roll.
- Rope channel design creates uniform tarp tension for a better fitting and longer lasting tarp.
- Telescoping crank handle with flex drive system rolls and unrolls the tarp at many angles with ease.

## AUTOLOCK® ELECTRIC TARP

for boxes 18' to 53' long

- Motor is constructed of corrosion resistant, durable metal housing.
- Unique DUAL DRIVE™ System has a wind resistant design featuring a strong synthetic cable and tension spring that work together to provide a powerful front and rear drive to cover your load.
- Rotating and telescoping motor mount allows roll tube to rise and flex over heaped loads, reducing stress on the drive components and pivot arm.
- Extra durable 3" aluminum roll tube is strong, yet lightweight offering a faster and straighter roll.

## EZ-LOC® ROLL-UP TARP

for boxes up to 53' long

- 2" aluminum roll tube is rust resistant and strong, yet lightweight to minimize tarp wear.
- Rope channel design creates uniform tarp tension for a better fitting and longer lasting tarp.
- Custom end caps with crimped standing seam is self sealing and flexible, no welds to break.
- Premium commercial grade, UV resistant vinyl remains flexible at -40° F.
- Quick release aluminum tarp stops.
- Heavy duty stainless steel U-joint with 21 splines for fine tuning tarp tension.

**FERTILIZER, CONSTRUCTION AND STAINLESS STEEL**

## FEATURE COMPARISON CHART

		SRT-2	AUTOLOCK	EZ-LOC
<b>End Caps</b>	<b>Material</b>	Stainless steel up to 118" wide box	Stainless steel up to 102" wide box	Stainless steel up to 118" wide box
	<b>Profile</b>	14" deep, with bracket attachment 7" or 12" rise available dependent on box width		14" deep, bolt through attachment 7" or 12" rise available dependent on box width
		All end caps have crimped built-in wind deflector and support bow		
	<b>Stainless Steel Option</b>	End caps, stationary tube, tarp stop bracket, cables, bows and hardware		
	<b>Weather Seal</b>	Included		None
<b>Ridge Strap(s)</b>	1 ridge strap	2 ridge straps	1 ridge strap	
<b>Tarp Stops</b>	Aluminum quick release with integrated set screw on front and rear			
<b>Roll Tube</b>	3" aluminum		2" aluminum	
<b>Tension System</b>	Spring loaded spool, set at install with cable and ratchet on both ends, no adjustment needed	Drive line and tension spring set at install on both ends, z adjustment needed	21 spline adjustable zinc plated U-joint crank handle	
<b>Front and Rear Roll Return</b>	Integrated in the tensioning system		Front bungee return Optional - Front spring return Front or rear cable return Rear bungee return	
<b>Tarp Attachment</b>	Rope in channel			
<b>Tarp Construction</b>	Premium commercial grade, UV resistant 18 oz. vinyl fabric Optional - 22 oz. vinyl fabric for EZ-LOC and AUTOLOCK			
<b>Tarp Colors</b>	Black, white, gray, blue, red, orange, green, yellow and brown Optional - Multi-colored or 22 oz. black, white, gray, blue and red			
<b>Electric Kit</b>	Optional - see page 20	Included	Optional - see page 21	

# FERTILIZER SPREADER AND TENDER BOX KIT PRICING

## SRT-2® SPOOL ROLL TARP

- Spring loaded spools
- Stainless steel tension ratchets
- Extra durable 3" aluminum roll tube
- Telescoping crank handle with flex drive system
- 18 oz. vinyl
- Powder coated quick release aluminum tarp stops with stainless steel base
- 14" deep, 7" rise stainless steel end caps (front side mounted and rear top mounted)
- Stainless steel bows
- 1 ridge strap

STANDARD TARP KIT PRICING FOR FERTILIZER SPREADERS AND TENDER BOXES				For pricing round box length up to nearest foot.
Box Length in ft. up to 96" wide	Bows (included)	Standard 7" Rise	12" Rise	
8'	2	\$1,422.25	\$1,518.50	
9'	2	\$1,449.50	\$1,545.75	
10'	2	\$1,479.50	\$1,575.75	
11'	3	\$1,586.00	\$1,682.25	
12'	3	\$1,614.75	\$1,711.00	
13'	3	\$1,642.00	\$1,738.25	
14'	3	\$1,672.00	\$1,768.25	
15'	4	\$1,777.25	\$1,873.50	
16'	4	\$1,807.00	\$1,903.25	
17'	4	\$1,834.50	\$1,930.75	
18'	4	\$1,863.00	\$1,959.25	
19'	5	\$1,969.50	\$2,065.75	
20'	5	\$1,999.50	\$2,095.75	
21'	5	\$2,026.75	\$2,123.00	
22'	5	\$2,055.50	\$2,151.75	
23'	6	\$2,181.50	\$2,277.75	
24'	6	\$2,210.00	\$2,306.25	

## FERTILIZER SPREADER AND TENDER BOX OPTIONS AND ACCESSORIES

OPTIONS FOR FERTILIZER SPREADER AND TENDER BOX TARP KITS			
	Options	Add / Deduct	PRICE
END CAP OPTIONS	Box Width 96-1/2" up to 102" Stainless Steel Wide Option (7" or 12" rise)	Add	\$156.00
	Box Width 102-1/2" up to 118" Wide Stainless Steel w/ 7" or 12" rise, boxes 118-1/2" to 120" w/ 7" rise only	Add	\$286.00
	End Cap, "Z" Bracket	Add	\$22.25
	No End Caps (pair)	Deduct	-\$88.50
MISC. OPTIONS	Stainless Steel Bow - Side Mount (extra) (each)	Add	\$94.00
	Stainless Steel Bow - Top Mount (extra) (each)	Add	\$84.50
	No Standard Bows (each)	Deduct	-\$21.00
	HD Aluminum Bows (each)	Add	\$47.00
	18 oz. Tarp in Multi-Color (per kit)	Add	\$39.00
	Stainless Steel Ridge Strap (each) (for kits up to 24' long)	Add	\$23.00
	No Ridge Strap	Deduct	-\$10.50
ELECTRIC OPTIONS	SRT-2 Electric Conversion Kit (fertilizer tender trailer) cab operated (upgrade)	Add	\$734.00
	SRT-2 Electric Conversion Kit (truck box no hoist) cab operated (upgrade)	Add	\$650.00
	Wireless System w/ Switch and Remote Control (Add to cost of Electric Kit)	Add	\$450.00
	Switch Control Electric System Upgrade (Add to cost of Electric Kit)	Add	\$340.00
ACCESSORIES			
Part #	Description	PRICE	
80055	Bow Cover	\$7.85 ea.	

# SEMI TRAILER AND FARM TRUCK KIT PRICING

STANDARD TARP KIT PRICING FOR SEMI AND FARM TRUCKS For pricing round box length to nearest foot.				
Box Length in ft.	AUTOLOCK		EZ-LOC	
Up to 96" wide	Bows*	PRICE	Bows**	PRICE
8'	-	-	2	\$1,535.75
9'	-	-	2	\$1,557.75
10'	-	-	2	\$1,579.75
11'	-	-	2	\$1,602.00
12'	-	-	2	\$1,711.25
13'	-	-	2	\$1,733.25
14'	-	-	2	\$1,754.00
15'	-	-	3	\$1,845.00
16'	-	-	3	\$1,867.25
17'	-	-	3	\$1,889.25
18'	3	\$3,592.25	3	\$1,910.00
19'	4	\$3,613.00	4	\$2,019.25
20'	4	\$3,639.00	4	\$2,041.50
21'	4	\$3,660.00	4	\$2,063.50
22'	4	\$3,680.75	4	\$2,085.50
23'	5	\$3,706.75	5	\$2,176.50
24'	5	\$3,727.50	5	\$2,198.75
25'	5	\$3,790.00	5	\$2,114.25
26'	5	\$3,810.75	5	\$2,137.50
27'	6	\$3,836.75	6	\$2,159.75
28'	6	\$3,857.50	6	\$2,183.00
29'	6	\$3,878.25	6	\$2,206.50
30'	6	\$3,904.25	6	\$2,228.50
31'	7	\$3,925.00	7	\$2,252.00
32'	7	\$3,946.00	7	\$2,274.00
33'	7	\$3,966.75	7	\$2,297.50
34'	8	\$3,992.75	8	\$2,321.00
35'	8	\$4,013.50	8	\$2,343.00
36'	8	\$4,060.25	8	\$2,366.50
37'	8	\$4,081.00	8	\$2,409.25
38'	8	\$4,102.00	8	\$2,431.50
39'	9	\$4,122.75	9	\$2,454.75
40'	9	\$4,143.50	9	\$2,477.00
41'	9	\$4,169.50	9	\$2,500.25
42'	9	\$4,190.25	9	\$2,523.75
43'	9	\$4,211.00	9	\$2,545.75
44'	10	\$4,237.00	10	\$2,570.50
45'	10	\$4,258.00	10	\$2,592.50
46'	10	\$4,278.75	10	\$2,616.00
47'	11	\$4,299.50	11	\$2,638.00
48'	11	\$4,325.50	11	\$2,661.50
49'	11	\$4,346.25	11	\$2,685.00
50'	11	\$4,367.00	11	\$2,707.00
51'	12	\$4,393.00	12	\$2,730.50
52'	12	\$4,414.00	12	\$2,772.00
53'	12	\$4,434.75	12	\$2,794.00
54'	12	\$4,455.50	-	-
55'	12	\$4,481.50	-	-
56'	12	\$4,502.25	-	-

## EZ-LOC® ROLL-UP TARP

- 2" aluminum roll tube
- 14" deep, 7" rise stainless steel end caps (front side and rear top mounted)
- Heavy duty stainless steel 21 spline U-joint
- 18 oz. vinyl
- Powder coated quick release aluminum tarp stops with stainless steel base
- Adjustable crank handle with pinless retainer
- Front bungee return system
- Stainless steel bows
- 1 ridge strap

## AUTOLOCK® ELECTRIC TARP

- High output electric motor
- Unique DUAL DRIVE™ System
- Stainless steel rotating and telescoping arm
- Extra durable 3" aluminum roll tube
- 14" deep, 7" rise stainless steel end caps (front side and rear top mounted)
- Powder coated quick release aluminum tarp stops with stainless steel base
- 18 oz. vinyl
- No arm to obstruct the back of the trailer
- Stainless steel bows
- 2 ridge straps

\*Bows not included. Table gives suggested bow quantities to order if needed.

\*\*Bows not included for box lengths 25' and up. Table gives suggested quantities to order if needed.

**FERTILIZER, CONSTRUCTION AND STAINLESS STEEL**

# SEMI TRAILER AND FARM TRUCK OPTIONS AND ACCESSORIES

**FERTILIZER, CONSTRUCTION AND STAINLESS STEEL**

OPTIONS FOR SEMI TRAILER AND FARM TRUCK TARP KITS			
	Options	Add / Deduct	PRICE
END CAP OPTIONS	Box Width 96-1/2" up to 102" Stainless Steel Wide Option (7" or 12" rise)	Add	\$156.00
	Box Width 102-1/2" up to 118" Wide Stainless Steel w/ 7" or 12" rise, boxes 118-1/2" to 120" w/ 7" rise only	Add	\$286.00
	End Cap, "Z" Bracket	Add	\$22.25
	No End Caps (pair)	Deduct	-\$88.50
	Rear Fabric Filler (each) (Semi Only)	Add	\$114.50
	Universal Front Stainless Steel Metal Filler (each) (Semi Only)	Add	\$131.50
	BOWS / STRAPS	Stainless Steel Bow - Side Mount (extra) (each)	Add
Stainless Steel Bow - Top Mount (extra) (each)		Add	\$84.50
No Bows (each) (Farm Truck Only)		Deduct	-\$21.00
Stainless Steel Ridge Strap (each) (for kits 8-24')		Add	\$23.00
Stainless Steel Ridge Strap (each) (for kits from 25'-53' long)		Add	\$39.00
No Ridge Strap (each)		Deduct	-\$10.50
RETURN OPTIONS	Rear Bungee Roll Return (for rear of hand crank systems) Part # 50753	Add	\$50.75
	Cable Return, Drive Side	Add	\$151.00
	Cable Return, Non-Drive Side	Add	\$105.50
TARP WEIGHT	18 oz. Tarp in Multi-Color (per kit)	Add	\$39.00
	22 oz. Tarp Fabric in Black, White, Gray, Blue, Red (per lin. ft.)	Add	\$1.36
ELECTRIC OPTIONS	Electric Conversion Kit w/ Cable Return for Stainless Steel EZ-LOC Roll-Up Tarp (semi trailer) cab operated	Add	\$929.00
	Electric Conversion Kit w/ Cable Return for Stainless Steel EZ-LOC Roll-Up Tarp (farm box w/ hoist) cab operated	Add	\$989.00
	Wireless System w/ Switch and Remote Control (Add to cost of Electric Kit)	Add	\$450.00
	Switch Control Electric System Upgrade (Add to cost of Electric Kit)	Add	\$340.00
ACCESSORIES			
Part #	Description		PRICE
80388	Tarp Safety Cords (2 pack)		\$82.95 ea.
60691	Deflector, Roll Tube w/ 2 Bolts		\$8.79 ea.
80055	Bow Cover		\$7.85 ea.
90613	Rolltection Tarp Safety Cords (2 pack)		\$51.95 ea.



# CONSTRUCTION DUMP BOX KIT PRICING

## SRT-2® SPOOL ROLL TARP

- Spring loaded spools
- Stainless steel tension ratchets
- Extra durable 3" aluminum roll tube
- Telescoping crank handle with flex drive system
- Powder coated quick release aluminum tarp stops with stainless steel base
- Heavy duty aluminum bows
- 18 oz. vinyl

**NOTE: The SRT-2 Construction Dump Box requires some form of an end cap system to perform (we have two options listed below). If no end caps are chosen, it is assumed the customer is supplying their own compatible end caps.**

STANDARD TARP KIT PRICING FOR CONSTRUCTION DUMP BOX				For pricing round box length up to nearest foot.	
Box Length in ft. up to 96" wide	Bows not included Suggested quantities below	Flat / 4" Rise Front: Rubber air dam w/ HD bow Rear: HD bow	Standard 7" Rise Front: Standard 7" rise stainless steel end cap Rear: HD bow		
8'	2	\$1,154.50	\$1,237.75		
9'	2	\$1,180.50	\$1,263.75		
10'	2	\$1,206.50	\$1,295.00		
11'	3	\$1,237.75	\$1,321.00		
12'	3	\$1,263.75	\$1,352.00		
13'	3	\$1,289.75	\$1,378.00		
14'	3	\$1,315.75	\$1,409.25		
15'	4	\$1,341.75	\$1,435.25		
16'	4	\$1,373.00	\$1,466.50		
17'	4	\$1,399.00	\$1,497.75		
18'	4	\$1,425.00	\$1,523.75		
19'	5	\$1,477.00	\$1,575.75		
20'	5	\$1,503.00	\$1,601.75		

## CONSTRUCTION DUMP BOX OPTIONS AND ACCESSORIES

OPTIONS FOR CONSTRUCTION DUMP BOX TARP KITS			Flat	4" Rise	Standard 7" Rise
END CAP OPTIONS	Options	Add / Deduct	PRICE	PRICE	PRICE
	No Front Rubber Air Dam w/ HD Aluminum Bow	Deduct	\$104.00	\$104.00	NA
	No Front Standard 7" Rise Stainless Steel End Cap (side or top mounted)	Deduct	NA	NA	\$44.25
	Universal Front, Stainless Steel Metal Filler (each)	Add	NA	NA	\$131.50
	Boxes 96-1/2" up to 102" Wide Option	Add	\$156.00	\$156.00	\$156.00
	No Rear HD Aluminum Bow	Deduct	\$47.00	\$47.00	\$47.00
	Rear Stainless Steel End Cap Standard 7" Rise (substitute for rear bow)	Add	NA	NA	\$265.25
	Front Stainless Steel Flat End Cap (side or top mounted)	Add	\$208.00	NA	NA
	Rear Stainless Steel Flat End Cap (side or top mounted)	Add	\$265.25	NA	NA
MISC. OPTIONS	End Cap, "Z" Bracket Stainless Steel (brackets for 1 end cap) (use for boxes with rails wider than 4")	Add	\$22.25	\$22.25	\$22.25
	HD Aluminum Bows (each)	Add	\$87.25	\$87.25	\$87.25
	18 oz. Tarp in Multi-Color (per kit)	Add	\$39.00	\$39.00	\$39.00
	Drain Holes (each) (include drain hole box detail sheet with order)	Add	\$5.25	\$5.25	\$5.25
ELECTRIC OPTIONS	SRT-2 Electric Conversion Kit (Construction Box Trailer) cab operated (upgrade)	Add	\$794.00	\$794.00	\$794.00
	Wireless System w/ Switch and Remote Control (add to cost of Electric Kit)	Add	\$450.00	\$450.00	\$450.00
	Switch Control Electric System Upgrade (add to cost of Electric Kit)	Add	\$340.00	\$340.00	\$340.00
	Dual Pole Connector Socket and Plug Kit (needed when ordering electric tarp for pup trailer)	Add	\$73.00	\$73.00	\$73.00
	Wire 6 Ga. 2 Strand (price per linear foot) (extra wire needed for tongue of pup trailer)	Add	\$5.45	\$5.45	\$5.45

**FERTILIZER, CONSTRUCTION AND STAINLESS STEEL**

# BELLY DUMPS

SRT-2® Electric Spool Roll Tarp



# BELLY DUMP TARP SYSTEM KIT PRICING

## SRT-2® SPOOL ROLL TARP

- Spring loaded spool
- Tension ratchets
- Extra durable 3" aluminum roll tube
- Telescoping crank handle with flex drive system
- Custom wood end caps
- Quick release aluminum tarp stops
- 18 oz. vinyl

STANDARD TARP KIT PRICING FOR BELLY DUMPS		For pricing round box length up to nearest foot.	
Box Length in ft.	Manual Kit 96" Wide Box	Manual Kit 97" to 102" Wide Box	
14'	\$1,317.00	\$1,419.75	
15'	\$1,330.00	\$1,432.75	
16'	\$1,344.25	\$1,445.75	
17'	\$1,374.25	\$1,458.75	
18'	\$1,387.25	\$1,471.75	
19'	\$1,400.25	\$1,484.75	
20'	\$1,413.25	\$1,499.00	

## OPTIONS AND ACCESSORIES

OPTIONS FOR BELLY DUMP TARP KITS		
Option	Add / Deduct	PRICE
18 oz. Tarp in Multi-Color (per kit)	Add	\$39.00
SRT-2 Electric Conversion Kit, Belly Dump (cab operated) (upgrade)	Add	\$814.00
Wireless System w/ Switch and Remote Control (Add to cost of Electric Kit)	Add	\$450.00
Switch Control Electric System Upgrade (Add to cost of Electric Kit)	Add	\$340.00



**BELLY DUMPS**

# SEMI GRAIN AND PUP TRAILER BOX DETAIL SHEET

Please complete form thoroughly.

Missing information may delay order processing.

Date: \_\_\_\_\_

ACI Sales Representative: \_\_\_\_\_

Phone 800-233-4655

Fax 800-592-4460

Email [orderdesk@agricover.com](mailto:orderdesk@agricover.com)

Mail PO BOX 508

Jamestown, ND 58402

NOTE: Accurate PHYSICAL measurements are ESSENTIAL for proper tarp fit. Always use actual tape measurements. NEVER RELY ON UNIVERSAL BOX SIZES.

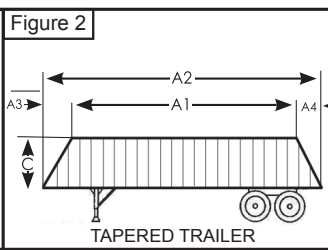
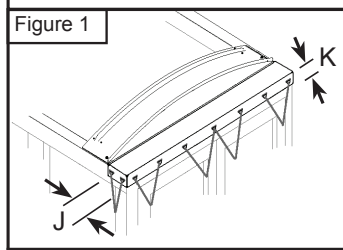
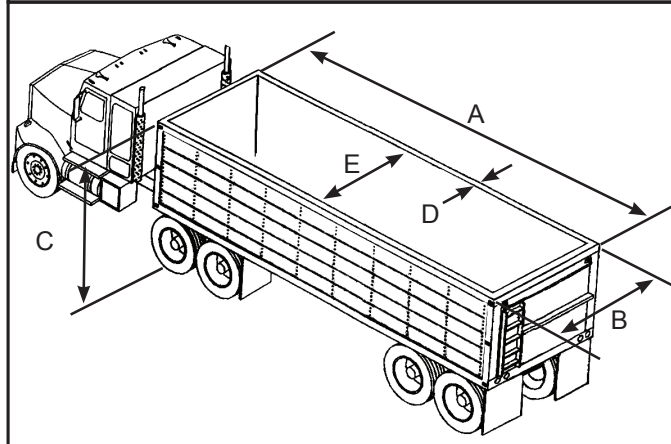

To measure radius corners, place a **carpenter's square** on the front radius of the trailer. Measure at the point where the radius starts to arch around the front of the trailer.

### BOX MEASUREMENTS

A \_\_\_\_\_ Top Box Length (For Tapered Trailer, give A1, A2, A3 and A4)  
 A1 \_\_\_\_\_ Tapered Top Length    A3 \_\_\_\_\_ Front  
 A2 \_\_\_\_\_ Tapered Lower Length    A4 \_\_\_\_\_ Rear  
 B \_\_\_\_\_ Front Top Box Width Center Rear  
 C \_\_\_\_\_ Box Height (from ground)  
 D \_\_\_\_\_ Top Rail Width  
 E \_\_\_\_\_ Inside Box Width

### CORNER CONFIGURATION

Square     Diagonal     Radius (additional cost)  
 F \_\_\_\_\_ Outside Corner Radius (needed on all radius fronts)  
 G \_\_\_\_\_ Flat Across Front  
 H \_\_\_\_\_ Flat Across Diagonal  
 I \_\_\_\_\_ Diagonal Depth

\*Optional Items are additional cost  
 \*\* 22 oz. fabric available in Black, White, Gray, Blue, Red only.

### CONTACT INFORMATION

Name \_\_\_\_\_  
 Address \_\_\_\_\_  
 City \_\_\_\_\_ State \_\_\_\_\_ Zip \_\_\_\_\_  
 Phone \_\_\_\_\_ Fax \_\_\_\_\_  
 Box/Trailer Make & Year \_\_\_\_\_

### TYPE OF TRAILER BOX & TARP SYSTEM

EZ-LOC, AUTOLOCK & ROLTEC systems up to 53' long  
 Semi Trailer     Pup Trailer     Manual     Electric  
 ROLTEC Side Locking     AUTOLOCK Electric Tarp  
 EZ-LOC Roll-Up Tarp     AUTOLOCK Electric Tarp SST  
 EZ-LOC Roll-Up Tarp SST     Cab Operated Electric  
 Switch and Remote Control     Switch Control

### OPTIONS

**BOWS**     Add Bows\* Qty. \_\_\_\_\_     Do Not Add Bows  
 Add HD Aluminum Bows\* Qty. \_\_\_\_\_  
**END CAPS**    Standard kit comes with Galvanized Standard 7" Rise End Caps. Please specify if you would like different end caps.  

Material	Rise	Front	Rear
<input type="checkbox"/> Galvanized	<input type="checkbox"/> 7"	<input type="checkbox"/> Top Mount	<input type="checkbox"/> Top Mount
<input type="checkbox"/> Aluminum	<input type="checkbox"/> 12"	<input type="checkbox"/> Side Mount	<input type="checkbox"/> Side Mount
<input type="checkbox"/> Stainless Steel			

**On ROLTEC Tarp Orders, Select Depth of End Caps:**  
 10" Deep Standard     14" Deep Option\*  
**On EZ-LOC Tarp Orders Add Bolt-On End Cap Bracket:**  
 No     Yes\*  
**Quick Release End Cap Bracket Option\***  
 Yes     No    (available in Galvanized or Aluminum only)  
**Rear Filler Option\* (see Figure 1)**  
 J \_\_\_\_\_ Dimension of filler from back of gate to front of hinge pin where end cap will set (inches)  
 K \_\_\_\_\_ Dimension of drop (inches)

**TARP FABRIC**     18 oz.     22 oz.\*\*     Mesh  
(Available in black only)  
**TARP COLOR**    Standard kit comes with a black tarp. Please specify if you would like a different color.  
 Black\*\*     White\*\*     Gray\*\*     Green     Blue\*\*  
 Orange     Red\*\*     Brown     Yellow  
 **Optional\* 18 oz. Multi-Color (Please select 2 colors above)**

Notes/Additional Part Numbers:  
 \_\_\_\_\_  
 \_\_\_\_\_  
 \_\_\_\_\_

BOX DETAIL SHEETS

By submitting this order, I accept the terms and conditions of Agri-Cover, Inc.

**NO RETURNS**

# SEMI GRAIN AND PUP TRAILER ELECTRIC KIT BOX DETAIL SHEET

**Please complete form thoroughly.**

Missing information may delay order processing.

Date: \_\_\_\_\_

ACI Sales Representative: \_\_\_\_\_

**Phone** 800-233-4655

**Fax** 800-592-4460

**Email** orderdesk@agricover.com

**Mail** PO BOX 508

Jamestown, ND 58402

<p>NOTE: Accurate PHYSICAL measurements are ESSENTIAL for proper tarp fit. Always use actual tape measurements. NEVER RELY ON UNIVERSAL BOX SIZES.</p> <p>If installing on a trailer with an existing electric tarp (not an Agri-Cover system) additional wiring components may be needed.</p> <p><b>NOTE: Prices for option below are in addition to cost of tarp.</b></p> <p><b>ELECTRIC TARP KITS</b> (See Ag Price Book for Kit Numbers)</p> <p><input type="checkbox"/> Grain Trailer Kit # _____</p> <p><input type="checkbox"/> Pup Trailer Kit # _____</p> <p>NOTE: If not installing an electric tarp on lead trailer, <b>PN 90144</b> will need to be ordered. If not installing an electric tarp on pup trailer, <b>PN 40918</b> will need to be ordered. (See Below)</p> <p><b>ELECTRIC HOPPER KITS</b> (See Ag Price Book for Kit Numbers)</p> <p><input type="checkbox"/> Grain Trailer Kit # _____</p> <p><input type="checkbox"/> Pup Trailer Kit # _____</p>	<p><b>CONTACT INFORMATION</b></p> <p>Name _____</p> <p>Address _____</p> <p>City _____ State _____ Zip _____</p> <p>Phone _____ Fax _____</p> <p>Box/Trailer Make &amp; Year _____</p> <hr/> <p>Notes/Additional Part Numbers:</p> <p>_____</p> <p>_____</p> <p>_____</p> <p>_____</p> <p>_____</p> <p>_____</p> <p>_____</p>		
<p><b>EXTRAS NEEDED</b></p>			
<table style="width: 100%; border: none;"> <tr> <td style="width: 50%; vertical-align: top; border: none;"> <p><input type="checkbox"/> Eyelet Terminal Ring 1/4" (2 extra needed) - Quantity _____ <b>PN 60598</b></p> <p><input type="checkbox"/> Heat Shrink Kit (10 pieces included) <b>PN 30649</b></p> <p><input type="checkbox"/> Extra Wire (see diagram below) <b>PN 60768</b></p> </td> <td style="width: 50%; vertical-align: top; border: none;"> <p><input type="checkbox"/> Cable Tie 11" - Quantity _____ <b>PN 10867</b></p> <p><input type="checkbox"/> Dual Pole Connector (if needed) <b>PN 40918</b></p> <p><input type="checkbox"/> Tractor Wiring Kit (if needed) <b>PN 90144</b></p> </td> </tr> </table> <p>A. Select best routing along frame from the dual pole connector at the front of the lead trailer (location of dual pole connector) to the rear of the lead trailer (location of second dual pole connector). Measure amount of wire needed. _____ ft</p> <p>B. Select the best routing from dual pole connector at rear of lead trailer along tongue of pup to the mounting location of the control box on front of pup. Measure amount of wire needed. _____ ft</p> <p style="text-align: right;">Extra Wire <b>Total</b> Length (A+B) _____ ft</p>		<p><input type="checkbox"/> Eyelet Terminal Ring 1/4" (2 extra needed) - Quantity _____ <b>PN 60598</b></p> <p><input type="checkbox"/> Heat Shrink Kit (10 pieces included) <b>PN 30649</b></p> <p><input type="checkbox"/> Extra Wire (see diagram below) <b>PN 60768</b></p>	<p><input type="checkbox"/> Cable Tie 11" - Quantity _____ <b>PN 10867</b></p> <p><input type="checkbox"/> Dual Pole Connector (if needed) <b>PN 40918</b></p> <p><input type="checkbox"/> Tractor Wiring Kit (if needed) <b>PN 90144</b></p>
<p><input type="checkbox"/> Eyelet Terminal Ring 1/4" (2 extra needed) - Quantity _____ <b>PN 60598</b></p> <p><input type="checkbox"/> Heat Shrink Kit (10 pieces included) <b>PN 30649</b></p> <p><input type="checkbox"/> Extra Wire (see diagram below) <b>PN 60768</b></p>	<p><input type="checkbox"/> Cable Tie 11" - Quantity _____ <b>PN 10867</b></p> <p><input type="checkbox"/> Dual Pole Connector (if needed) <b>PN 40918</b></p> <p><input type="checkbox"/> Tractor Wiring Kit (if needed) <b>PN 90144</b></p>		

**BOX DETAIL SHEETS**

By submitting this order, I accept the terms and conditions of Agri-Cover, Inc.

**NO RETURNS**

# FARM TRUCK AND SEED TENDER BOX DETAIL SHEET

Please complete form thoroughly.

Missing information may delay order processing.  
 Date: \_\_\_\_\_  
 ACI Sales Representative: \_\_\_\_\_

Phone 800-233-4655  
 Fax 800-592-4460  
 Email orderdesk@agricover.com

Mail PO BOX 508  
 Jamestown, ND 58402

NOTE: Accurate PHYSICAL measurements are ESSENTIAL for proper tarp fit. Always use actual tape measurements. NEVER RELY ON UNIVERSAL BOX SIZES.

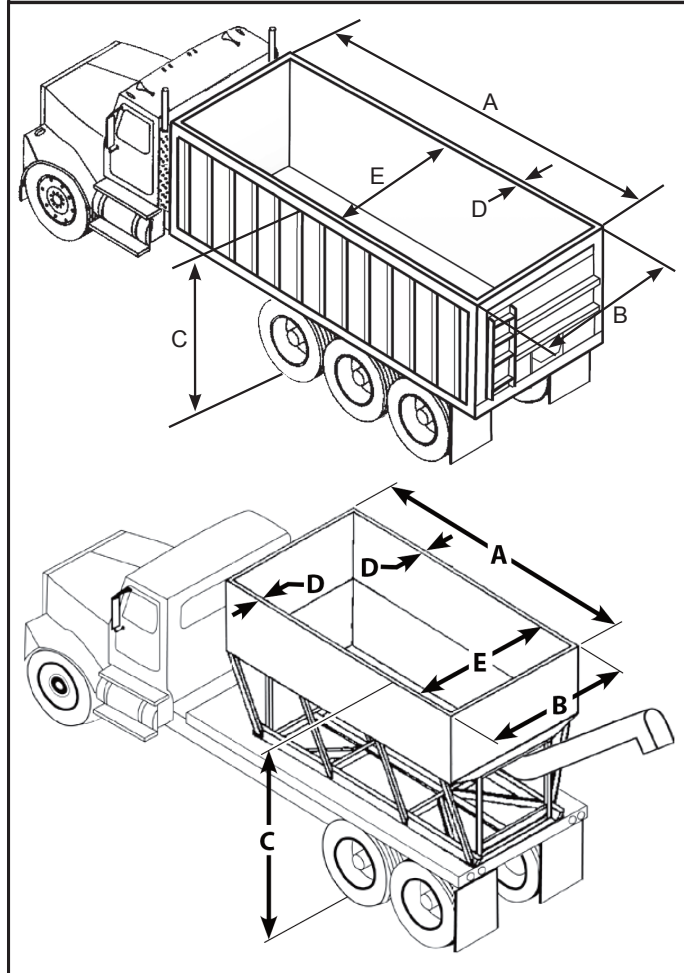

### BOX MEASUREMENTS

A \_\_\_\_\_ Top Outside Box Length  
 B \_\_\_\_\_ Front Top Box Width Center Rear  
 C \_\_\_\_\_ Box Height (from ground)  
 D \_\_\_\_\_ Top Rail Width  
 E \_\_\_\_\_ Inside Box Width

Notes/Additional Part Numbers:  
 \_\_\_\_\_  
 \_\_\_\_\_  
 \_\_\_\_\_

### CONTACT INFORMATION

Name \_\_\_\_\_  
 Address \_\_\_\_\_  
 City \_\_\_\_\_ State \_\_\_\_\_ Zip \_\_\_\_\_  
 Phone \_\_\_\_\_ Fax \_\_\_\_\_  
 Box/Trailer Make & Year \_\_\_\_\_

### TYPE OF TARP SYSTEM

- SRT-2®, EZ-LOC®, & ROLTEC® systems up to 24' long
- Manual  Electric
- SRT-2 Spool Roll Tarp  Switch and Remote Control  
 EZ-LOC Roll-Up Tarp  Switch Control  
 EZ-LOC Roll-Up Tarp SST  Cab Operated Electric  
 ROLTEC Side Locking Tarp

### OPTIONS

- BOWS**  Add Bows\* Qty. \_\_\_\_\_  Do Not Add Bows  
 Add HD Aluminum Bows\* Qty. \_\_\_\_\_
- END CAPS**  
 Select Rise (7" is standard):  7" Rise  12" Rise  
 Select Material (standard is Galv.):  Galv.  Alum.\*  SST\*
- Select Mounting Method** (Standard is Front Side, Rear Top)  
 Front Side Mounted  Front Top Mounted  
 Rear Side Mounted  Rear Top Mounted
- On ROLTEC Tarp Orders, Select Depth of End Caps:**  
 10" Deep Standard  14" Deep Option\*
- On EZ-LOC Tarp Orders Add Bolt-On End Cap Bracket:**  
 No  Yes\*
- Quick Release End Cap Bracket Option\***  
 Yes  No (available in Galvanized or Aluminum only)

### Rear Filler Option\* (see image to the right)

J \_\_\_\_\_ Dimension of filler from back of gate to front of hinge pin where end cap will set (inches)  
 K \_\_\_\_\_ Dimension of drop (inches)

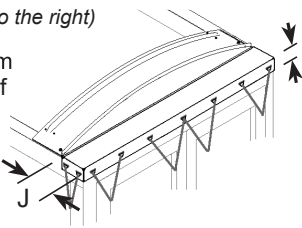

### TARP FABRIC

18 oz.  22 oz.\*\* (EZ-LOC & ROLTEC systems only)

### TARP COLOR

Standard kit comes with a black tarp. Please specify if you would like a different color.

Black\*\*  White\*\*  Gray\*\*  Green  Blue\*\*  
 Orange  Red\*\*  Brown  Yellow  
 **Optional\* 18 oz. Multi-Color** (Please select 2 colors above)

\*Optional Items are additional cost  
 \*\* 22 oz. fabric available in Black, White, Gray, Blue, Red only

BOX DETAIL SHEETS

By submitting this order, I accept the terms and conditions of Agri-Cover, Inc.

**NO RETURNS**

# GRAIN CART AND GRAIN WAGON BOX DETAIL SHEET

**Please complete form thoroughly.**

Missing information may delay order processing.

Date: \_\_\_\_\_

ACI Sales Representative: \_\_\_\_\_

**Phone** 800-233-4655

**Fax** 800-592-4460

**Email** orderdesk@agricover.com

**Mail** PO BOX 508

Jamestown, ND 58402

NOTE: Accurate PHYSICAL measurements are ESSENTIAL for proper tarp fit. Always use actual tape measurements. NEVER RELY ON UNIVERSAL BOX SIZES.

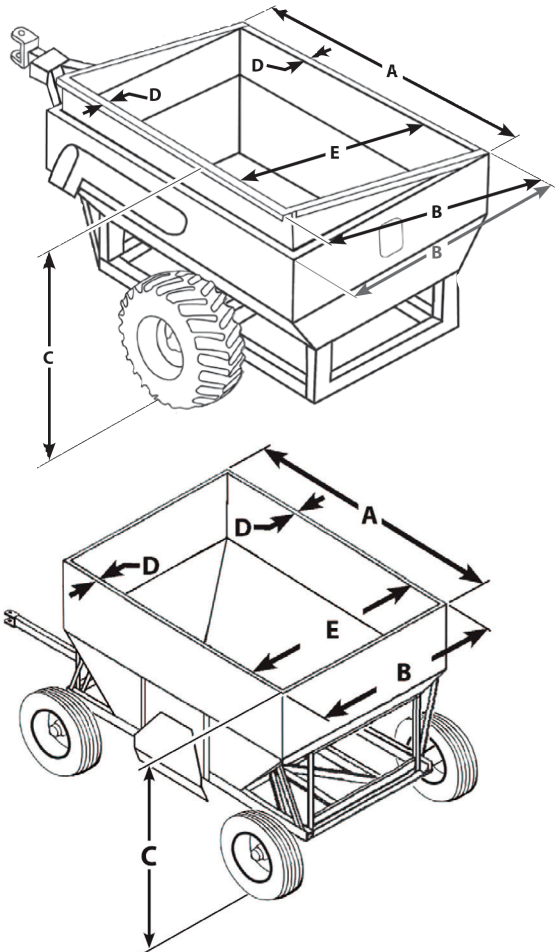

**BOX MEASUREMENTS** *Please provide EXACT measurements*

A \_\_\_\_\_ Top Outside Box Length  
 B \_\_\_\_\_ Top Outside Box Width  
 (If box has extensions measure outside of extensions on the angle)  
 C \_\_\_\_\_ Box Height (from ground)  
 D \_\_\_\_\_ Top Rail Width  
 E \_\_\_\_\_ Inside Box Width

Notes/Additional Part Numbers:  
 \_\_\_\_\_  
 \_\_\_\_\_  
 \_\_\_\_\_

**CONTACT INFORMATION**

Name \_\_\_\_\_  
 Address \_\_\_\_\_  
 City \_\_\_\_\_ State \_\_\_\_\_ Zip \_\_\_\_\_  
 Phone \_\_\_\_\_ Fax \_\_\_\_\_  
 Box/Trailer Make & Year \_\_\_\_\_

**TYPE OF TARP SYSTEM** SRT-2®, up to 24' Long; EZ-LOC® & ROLTEC® systems up to 30' Long

Manual  Electric  
 SRT-2 Manual  Switch and Remote Control  
 EZ-LOC Manual  Switch Control  
 ROLTEC Manual  Cab Operated Electric

**OPTIONS**

**BOWS**  Add Bows\* Qty. \_\_\_\_  Do Not Add Bows  
 Add HD Aluminum Bows\* Qty. \_\_\_\_

**END CAPS**

Select Rise (12" is standard):  7" Rise  12" Rise  Flat

Select Material (Split end caps over 118" wide)

Galvanized (up to 168" wide) (Standard)  
 Aluminum\* (up to 118" wide)  
 Stainless Steel\* (up to 118" wide)

Select Mounting Method (Standard is Front Side, Rear Side)

Front Side Mounted  Front Top Mounted  
 Rear Side Mounted  Rear Top Mounted

On ROLTEC Tarp Orders, Select Depth of End Caps:

10" Deep Standard  14" Deep Option\*

On EZ-LOC Tarp Orders Add Bolt-On End Cap Bracket:

No  Yes\*

Offset Bracket Base (For Boxes w/ Out-Turned Top Rail)\*

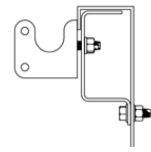

**TARP FABRIC**  18 oz.  22 oz.\*\*  
(EZ-LOC & ROLTEC systems only)

**TARP COLOR** *Standard kit comes with a black tarp. Please specify if you would like a different color.*

Black\*\*  White\*\*  Gray\*\*  Green  Blue\*\*  
 Orange  Red\*\*  Brown  Yellow  
 **Optional\* 18 oz. Multi-Color** (Please select 2 colors above)

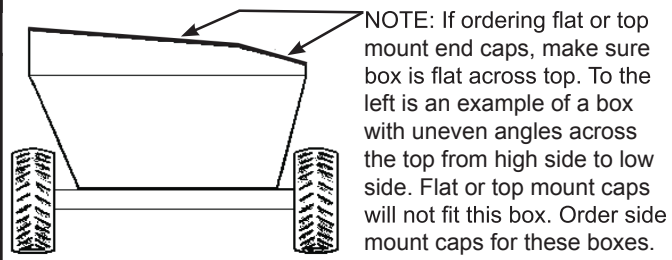

\*Optional Items are additional cost  
 \*\* 22 oz. fabric available in Black, White, Gray, Blue, Red only

By submitting this order, I accept the terms and conditions of Agri-Cover, Inc.

**NO RETURNS**

**BOX DETAIL SHEETS**

# STAINLESS STEEL BOX DETAIL SHEET FOR SRT-2® SPOOL ROLL TARP

**Please complete form thoroughly.**

Missing information may delay order processing.

Date: \_\_\_\_\_

ACI Sales Representative: \_\_\_\_\_

**Phone** 800-233-4655

**Fax** 800-592-4460

**Email** orderdesk@agricover.com

**Mail** PO BOX 508

Jamestown, ND 58402

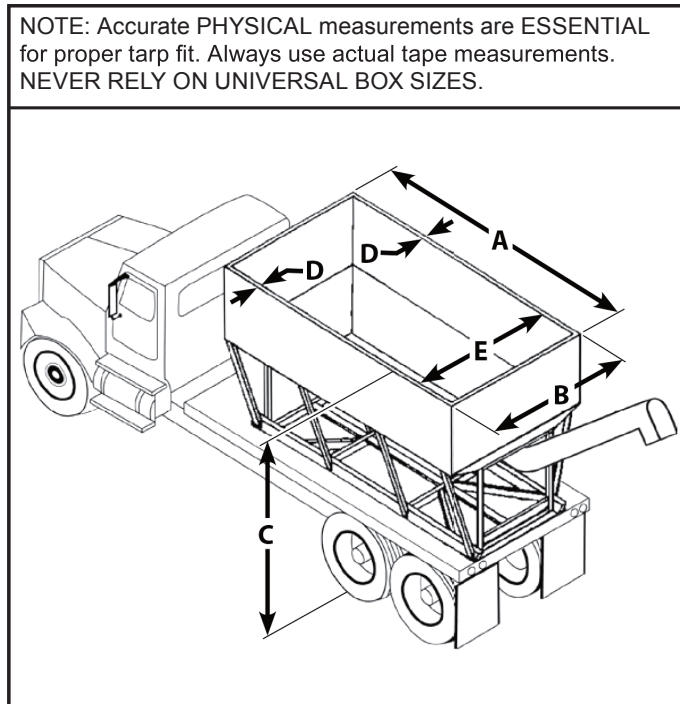

**IMPORTANT:**

- Manual crank handle will not work on air systems with rear manifold distributor.
- Manual crank handle will work on most spinner spreaders.
- AirMax/Loral may need an extension so tarp will roll over far enough to seal, boom rests may need minor modification to clear.
- Ag Chem Spreaders with inside granular bins require a special rear cap, set back 6".
- Loral units with rear granular attachment utilize same front and rear cap.

Notes/Additional Part Numbers:

\_\_\_\_\_

\_\_\_\_\_

\_\_\_\_\_

\_\_\_\_\_

\_\_\_\_\_

**CONTACT INFORMATION**

Name \_\_\_\_\_

Address \_\_\_\_\_

City \_\_\_\_\_ State \_\_\_\_\_ Zip \_\_\_\_\_

Phone \_\_\_\_\_ Fax \_\_\_\_\_

Box/Trailer Make & Year \_\_\_\_\_

**TYPE OF TARP SYSTEM** Up to 118" wide x 24" long

Manual  Electric

SRT-2® Spool Roll Tarp  Switch and Remote Control

Switch Control  Cab Operated

**OPTIONS**

**BOWS**  Add HD Aluminum Bows\* Qty. \_\_\_\_\_

Add Bows\* Qty. \_\_\_\_\_  Do Not Add Bows

**END CAPS** (Stainless Steel is Standard)

**Select Rise (12" is recommended):**  7" Rise  12" Rise

**Select Mounting Method** (Standard is Front Side, Rear Side)

Front Side Mounted  Front Top Mounted

Rear Side Mounted  Rear Top Mounted

**EQUIPMENT**

Spreader  Tender

Make: \_\_\_\_\_

Model: \_\_\_\_\_ Year: \_\_\_\_\_

**TARP FABRIC**  18 oz.

**TARP COLOR** Standard kit comes with a black tarp. Please specify if you would like a different color.

Black  White  Gray  Green  Blue

Orange  Red  Brown  Yellow

**Optional\* 18 oz. Multi-Color** (Please select 2 colors above)

**BOX MEASUREMENTS** Please provide **EXACT** measurements

A \_\_\_\_\_ Top Outside Box Length

B \_\_\_\_\_ Top Outside Box Width

C \_\_\_\_\_ Box Height (from ground)

D \_\_\_\_\_ Top Rail Width

E \_\_\_\_\_ Inside Box Width

\*Optional Items are additional cost

**BOX DETAIL SHEETS**

By submitting this order, I accept the terms and conditions of Agri-Cover, Inc.

**NO RETURNS**

# STAINLESS STEEL BOX DETAIL SHEET FOR SRT-2® CONSTRUCTION DUMP BOX

Please complete form thoroughly.

Missing information may delay order processing.

Date: \_\_\_\_\_

ACI Sales Representative: \_\_\_\_\_

Phone 800-233-4655

Fax 800-592-4460

Email orderdesk@agricover.com

Mail PO BOX 508

Jamestown, ND 58402

NOTE: Accurate PHYSICAL measurements are ESSENTIAL for proper tarp fit. Always use actual tape measurements. NEVER RELY ON UNIVERSAL BOX SIZES.

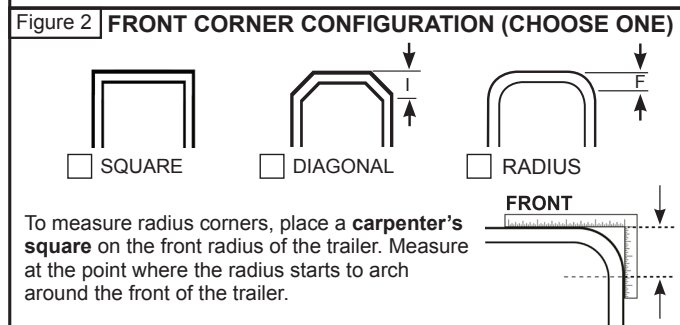
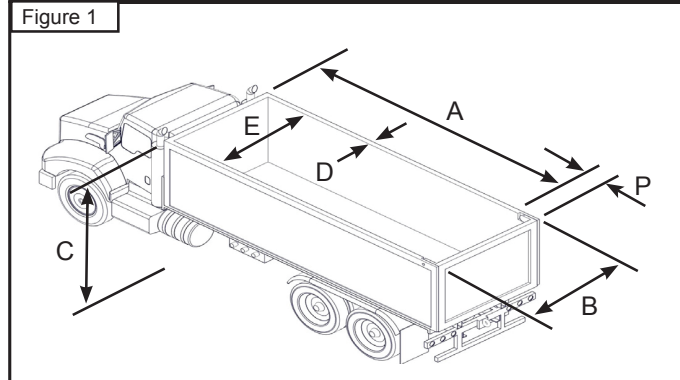

**BOX MEASUREMENTS (ALL FIELDS REQUIRED)**

- A \_\_\_\_\_ Top Box Length (front of box to front of hinge opening)
- B \_\_\_\_\_ Top Box Width
- C \_\_\_\_\_ Box Height (from ground)
- D \_\_\_\_\_ Top Rail Width
- E \_\_\_\_\_ Inside Box Width
- P \_\_\_\_\_ From front of Hinge Opening to rear of Trailer
- I \_\_\_\_\_ Diagonal front corner (see diagram above)
- F \_\_\_\_\_ Radius front Corner (see diagram above)

**NOTE: Max length of "I" and "F" is 24" for Electric Kits.**

- Is end cap placed at front face of box? **MUST CHOOSE ONE**
- Yes (customer supplies front corner filler pans if needed at corners with diagonal)
  - No (no front filler supplied with tarp)
  - No (front fabric filler supplied, only available with top mount end cap)
  - No (no metal filler supplied, only available with top mount end cap)

Notes/Additional Part Numbers:  
 \_\_\_\_\_  
 \_\_\_\_\_

**CONTACT INFORMATION**

Name \_\_\_\_\_  
 Address \_\_\_\_\_  
 City \_\_\_\_\_ State \_\_\_\_\_ Zip \_\_\_\_\_  
 Phone \_\_\_\_\_ Fax \_\_\_\_\_  
 Box/Trailer Make & Year \_\_\_\_\_

**TYPE OF TRAILER BOX & TARP SYSTEM**

- Truck Box  Pup Trailer  Manual  Electric
- Cab Operated Electric
- Switch and Remote Control
- Switch Control
- Dual Pole Connector Kit (for electric pup kits)
- Extra 6 Ga. wire needed (for electric pup kits) \_\_\_\_\_ ft.

**OPTIONS**

**END CAPS** *If no end caps are chosen it is assumed the customer is supplying their own compatible end caps.*

- Front End Cap** (must choose one)
- Rubber Air Dam w/ Bow (standard) (flat and 4" rise only)
  - End Cap Side Mount (flat and 7" rise only)
  - End Cap Top Mount (flat and 7" rise only)
  - None

- Rear End Cap** (must choose one)
- Bow Only (standard)
  - End Cap Side Mount (flat and 7" rise only)
  - End Cap Top Mount (flat and 7" rise only)
  - None

- Select Rise** (must choose one)
- Flat  4"  7"

- HD ALUMINUM BOWS\***
- Add Bows Custom Qty. \_\_\_\_\_  Add Bows Standard Qty.

- DRAIN HOLES\*** (include drain hole box detail sheet)
- Yes\*  No

- Add Bolt-On "Z" Bracket\*** (for use with box rails wider than 4")
- Yes\*  No

- TARP FABRIC**  18 oz.  Mesh (Available in black only)

**TARP COLOR** *Standard kit comes with a black tarp. Please specify if you would like a different color.*

- Black  White  Gray  Green  Blue
- Orange  Red  Brown  Yellow
- Optional\* 18 oz. Multi-Color** (Please select 2 colors above)

\*Optional items are additional cost

By submitting this order, I accept the terms and conditions of Agri-Cover, Inc.

**NO RETURNS**

**BOX DETAIL SHEETS**





# BOW REINFORCEMENT BOX DETAIL SHEET

**Please complete form thoroughly.**

Missing information may delay order processing.

Date: \_\_\_\_\_

ACI Sales Representative: \_\_\_\_\_

**Phone** 800-233-4655

**Fax** 800-592-4460

**Email** orderdesk@agricover.com

**Mail** PO BOX 508

Jamestown, ND 58402

NOTE: Accurate PHYSICAL measurements are ESSENTIAL for proper fit. Always use actual tape measurements. NEVER RELY ON UNIVERSAL BOX SIZES.

NOTE: Prices for option below are in addition to cost of tarp.

## CONTACT INFORMATION

Name \_\_\_\_\_

Address \_\_\_\_\_

City \_\_\_\_\_ State \_\_\_\_\_ Zip \_\_\_\_\_

Phone \_\_\_\_\_ Fax \_\_\_\_\_

Box/Trailer Make & Year \_\_\_\_\_

## BOW REINFORCEMENT (Part # 80231 \$72.80 per bow)

NOTE: Bow reinforcement straps are 12" wide and only come in black

Choose all that apply

Measure all dimensions from box edge

Measure all dimensions from tarp edge

QTY of Bows \_\_\_\_\_ (Fill in dimensions below in inches, round to nearest inch)

Standard Roll Application measure from front of end cap (solid line below)

Reverse Roll Application measure from rear of end cap (dashed line below)

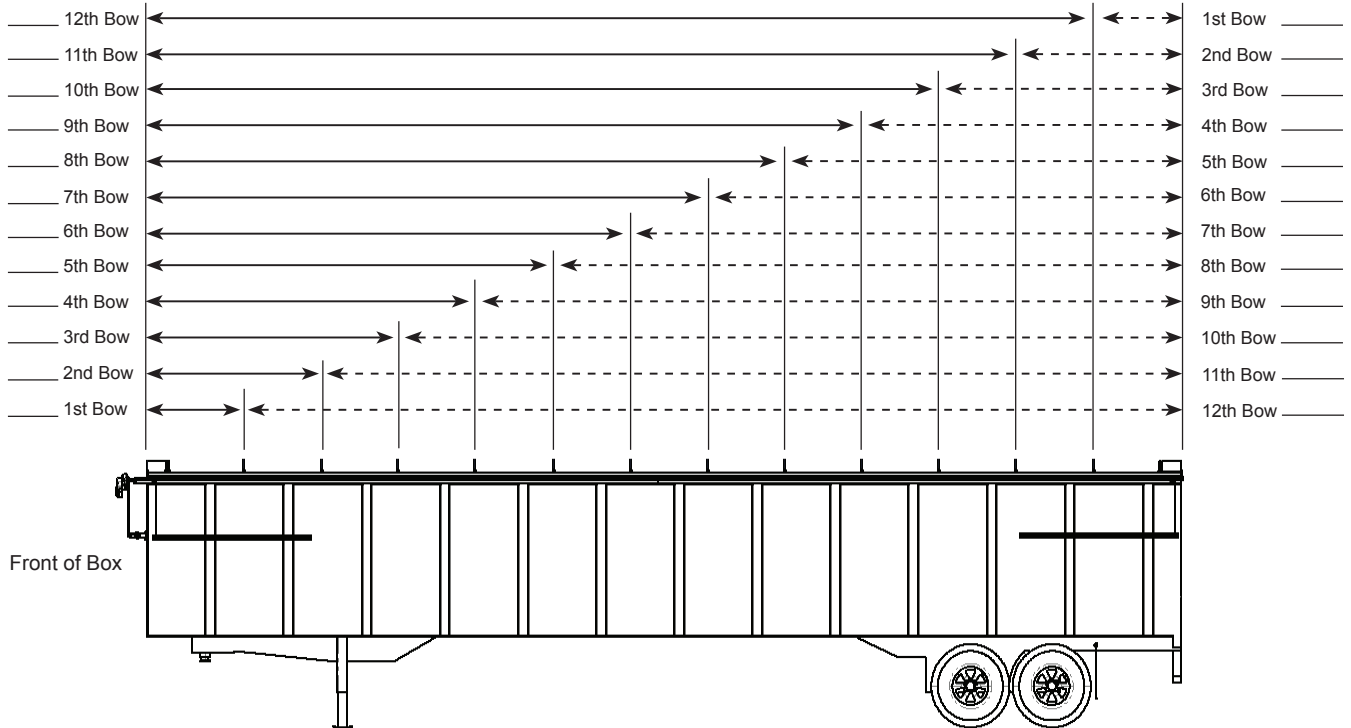

NOTE: Bow reinforcement available for up to 20 bows. Please provide additional information needed for additional bows in notes below.

Notes/Additional Part Numbers:

\_\_\_\_\_  
 \_\_\_\_\_  
 \_\_\_\_\_

**BOX DETAIL SHEETS**

By submitting this order, I accept the terms and conditions of Agri-Cover, Inc.

**NO RETURNS**

# DRAIN HOLES BOX DETAIL SHEET

**Please complete form thoroughly.**

Missing information may delay order processing.

Date: \_\_\_\_\_

ACI Sales Representative: \_\_\_\_\_

**Phone** 800-233-4655

**Fax** 800-592-4460

**Email** orderdesk@agricover.com

**Mail** PO BOX 508

Jamestown, ND 58402

NOTE: Accurate PHYSICAL measurements are ESSENTIAL for proper fit. Always use actual tape measurements. NEVER RELY ON UNIVERSAL BOX SIZES.

NOTE: Prices for option below are in addition to cost of tarp.

## CONTACT INFORMATION

Name \_\_\_\_\_

Address \_\_\_\_\_

City \_\_\_\_\_ State \_\_\_\_\_ Zip \_\_\_\_\_

Phone \_\_\_\_\_ Fax \_\_\_\_\_

Box/Trailer Make & Year \_\_\_\_\_

**DRAIN HOLES** (Part # 90753 \$5.20 per hole )

NOTE: Brass grommet with an inside diameter of 1/2"

### Choose all that apply

Measure all dimensions from box edge

Measure all dimensions from tarp edge

Top Outside Box Width \_\_\_\_\_ (This dimension is needed for both new and replacement tarps)

**MUST CHOOSE ONE OF THE FOLLOWING:** Top outside box width and end cap rise are needed to ensure drain holes are centered on box.

Flat end cap (drain holes will be centered on box)

7" rise end cap (drain holes will be centered on box)

12" rise end cap (drain holes will be centered on box)

Customer defined location: (please provide Dimension (A) see diagram below): Dimension (A) \_\_\_\_\_

NOTE: If Customer defines location, Dimension (A) will be translated directly to the finished tarp from the edge of the stationary tube. It will not take into consideration the width of box or the rise of end caps. Drain holes may not end up in the center of the box.

QTY of Drain Holes (up to 10) \_\_\_\_\_ (Fill in dimensions below in inches, round to nearest inch)

NOTE: If drain holes are not defined by the customer, AGRI-COVER will place them evenly spaced throughout the length of the tarp.

### LOCATIONS OF DRAIN HOLES

Standard Roll Application measure from front of end cap (solid line below)

Reverse Roll Application measure from rear of end cap (dashed line below)

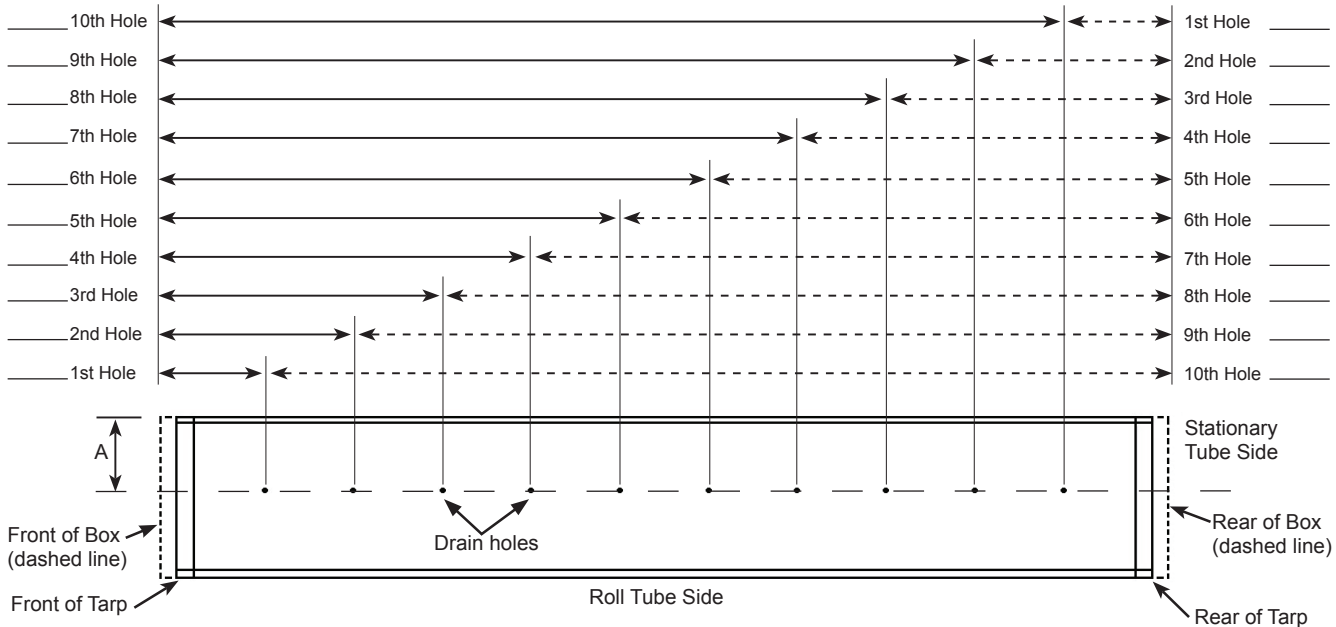

Notes/Additional Part Numbers:

\_\_\_\_\_

\_\_\_\_\_

**BOX DETAIL SHEETS**

By submitting this order, I accept the terms and conditions of Agri-Cover, Inc.

**NO RETURNS**



OUR PRODUCTS - YOUR SOLUTIONS™  
AGRICOVER.COM (800) 233-4655



© 2017 AGRI-COVER INC.  
ALL RIGHTS RESERVED  
Product subject to  
change without notice  
103117 80710\_F