



# Installation Manual

ROLTEC® ELECTRIC TARP CONVERSION  
WITH REAR SPRING BOX RETURN FOR  
EZ-LOC® TARP SYSTEMS



BY:  **AGRI-COVER, INC.**

**INSTALLER:** These instructions must be given to the consumer.

**CONSUMER:** Retain these instructions for further use. Save this manual for future reference.

**READ ALL INSTRUCTIONS CAREFULLY BEFORE INSTALLING OR USING THIS COVER.**

Actual parts may vary from those shown in this booklet.

*Tested. Trusted. Guaranteed.*

# Table of Contents

|   |            |
|---|------------|
| Safety .....                                | Page 2-3   |
| Operating Instructions .....                | Page 3     |
| Inspection and Maintenance.....             | Page 4     |
| Tools for Installation.....                 | Page 5     |
| Part Numbers and Diagrams.....              | Page 6-9   |
| Installing Roltec Conversion.....           | Page 10-18 |
| Installing Electrical Parts .....           | Page 18-22 |
| Edge Trim and Enabling Manual Override..... | Page 23    |
| Warranty .....                              | Back Page  |



**NOTICE TO CONSUMER:** This owner's manual applies to the ROLTEC® Electric Tarp Conversion. Before using this product, read the operating instructions, maintenance and safety sections of this owner's manual and save for future reference.

**NOTICE TO INSTALLER:** It is recommended you take the time to read these instructions carefully before installing this cover even if already familiar with the product. Often improvements are made without prior notice. Always handle components with care to avoid personal injury or damage to components. If you find a part missing or defective, or if you are having trouble installing this product call the customer service number on the back page. When done, these instructions must be given to the customer.

## FOR YOUR RECORDS:

DATE PURCHASED \_\_\_\_\_

WHERE PURCHASED \_\_\_\_\_

SERIAL NUMBER \_\_\_\_\_



## SAFETY INFORMATION



**NOTE:** If original decal becomes damaged or missing on arm, order replacement decal part number 70863.

**ATTENTION:** When performing maintenance procedures on spring arm, note arm is under spring pressure. Always use caution and assistance from another person if disassembly is required.

# SAFETY INFORMATION (Continued)

---

- Always use adequate caution when operating tarp.
  - Make sure tarp is open before unloading or loading.
  - Make sure nobody is on or near tarping system before and during operation.
  - Do not operate tarp with box hoisted in an elevated position.
  - If tarp is covered with snow, its removal is important before operating.
  - End caps must be free from grain that may be piled on them. Grain should not be heaped higher than end caps.
  - Do not operate this vehicle at highway speeds, while tarp system is in the “open” position.
  - Instruct everyone who will operate this tarp the proper procedures, or have them read this entire manual.
  - Do not directly spray the electric motor and electrical connections with a pressure washer.
- 

## ELECTRIC MOTOR OPERATING INSTRUCTIONS

---

**NOTE: For kits with a tarp control box, refer to the tarp control box manual for operating instructions.**

### 1: CLOSING TARP FROM OPEN POSITION

Push switch to the CLOSED position and hold. Visually view tarp position and release switch when tarp is fully closed. Fully closed is when tarp roll tube is tight up under latch plate.

### 2: OPENING TARP FROM CLOSED POSITION

Push switch to the OPEN position and hold. Visually view tarp position and release switch when tarp is fully open. Fully open is when tarp roll touches tarp stops. TOO TIGHT in open position could cause damage to tarp stops, tubes and tarp.

**IMPORTANT: Electric tarp system is equipped with a modified reset circuit breaker. Holding switch until circuit breaker trips is too long. When this occurs, breaker will trip and reset if the breaker is overloaded by the motor. To reduce unnecessary strain on components, always release switch before breaker trips. If breaker trips and does not reset, it may have detected a continuous short and will not reset until the short is repaired.**

# INSPECTION AND MAINTENANCE

- Periodic preventive maintenance should be practiced. Inspect tarp system often for proper operation.
- Periodically inspect front arm (and spiral springs) for loose or worn parts and replace as needed. Clean telescoping parts for smooth operation. **CAUTION:** Some lubricants attract dust, avoid using on telescoping components.
- Always use genuine Agri-Cover, Inc. replacement parts if repairs are needed.
- Periodically check the tightness of mounting bolts and electrical connections, remove any dirt or corrosion that may have accumulated on the electrical connections.
- The motor gearbox is lubricated with 5 ounces of mobil SHC 630 lubricant and sealed for life.
- Periodically grease zerk fittings and lubricate chain. Remove plastic plug to access zerk and chain inside gearbox.

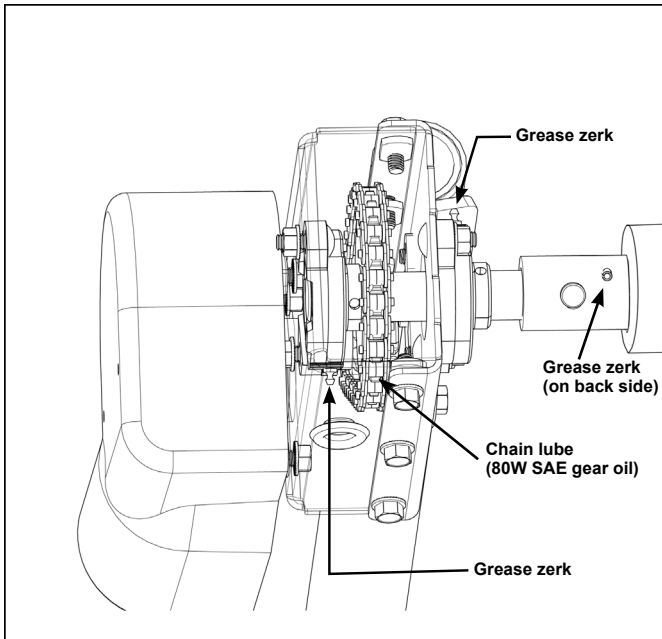

# PREPARATION

---

## TOOLS & EQUIPMENT

Most installations will require use of all these items

- Protective eyewear
- Tape measure
- Marking pencil
- 3/8" electric drill
- #2 and #3 Phillips driver bit
- 5/16", 7/23", 1/4", 5/16" and 1/2" drill bits
- Center punch
- Impact wrench
- 9/16" socket
- 9/16", 1/2", 7/16" and 3/8" combination wrench
- Metal hack saw
- Heat gun
- Wire cutter and crimper
- Grinder
- Hammer

---

## IMPORTANT NOTES:

The truck or trailer on which installation is being done must be parked on a level surface. This prevents box from twisting, which can cause a poor installation.

Box must be square and straight, center must not be pulled together or spread apart. Make adjustments prior to installation.

Inspect box for sharp edges or points that make contact with tarp and/or cables, remove or grind smooth.

It may be necessary to remove or reposition ladders or other devices that may interfere with system. If any modifications to box are needed, consult box manufacturer.

If you have an extension on top of your box, make sure it is secure by bolting in place.

Most fasteners used in this installation are 3/8" x 1" self threading bolts. A 5/16" hole must be drilled to obtain correct tap drill hole size. Attach these bolts only to secure structures on box. In some cases it will be necessary to use washer and nuts or other types of fasteners (NOT FURNISHED) to ensure a solid anchor.

# Part Numbers and Descriptions

(Item numbers are used to reference parts in diagrams throughout this manual)

| Item | Part #  | Description  | Item | Part #  | Description                                     |
|------|---------|--|------|---------|---|
|      | 80120   | ROLTEC Electric Tarp Conversion (for Side Locking Tarp Systems w/ 2" Steel Tube) | 26   | 70401   | Nut, Hex Nylock Flange, 3/8"-16, Gr-5, Zinc Pl  |
| 1    | 70670   | Gearbox Asm  | 27   | 80113   | Bushing , Spacer                                |
| 2    | 90447   | Upper Front Arm Asm  | 28   | 70626   | Spring, Spiral Torsion (4 req'd)                |
| 3    | 60583   | Bolt, Hex, Serrated Flange, 5/16-18 x 3/4", Gr-5, Zinc Pl, w/ Vibratite          | 29   | 70594   | Bolt, Carriage, 3/8"-16 x 3-3/4", Gr-5, Zinc Pl |
| 4    | 90428   | Plug, Grommet, 2"  | 30   | 60254   | Bolt, Carriage, 3/8"-16 x 1", Gr-5, Zinc Pl     |
| 5    | 40664   | Grommet, Rubber 7/16"  | 31   | 70584   | Bracket, Slant                                  |
| 6    | 70996   | Screw, Phillips Head 10-32 x 1/4", Zinc Pl, w/ Vibratite                         | 32   | 70646   | Plate Wmt, Pivot                                |
| 7    | 90479   | Washer, Pivot Arm  | 33   | 10901   | Bolt, 3/8" x 1" Gr-5, Zinc Pl                   |
| 8    | 90410   | Wear Tube, Pivot Arm   | 34   | 10185   | Flat Washer, 3/8"                               |
| 9    | 70575   | Cotter Pin   | 35   | 50670   | Bolt, Carriage, 3/8" x 1-1/2" Gr-5, Zinc Pl     |
| 10   | 70554   | Clevis Pin   | 36   | 70618   | Collar, Tube                                    |
| 11   | 4000189 | Cotter Pin   | 37   | 10914   | Screw, Self Drilling Phillips #14 x 1"          |
| 12   | 50833   | Nut, hex, Nylock, 3/8"-16 Gr-5, Zinc Pl  | 38   | 70952   | Cable Retainer                                  |
| 13   | 10906   | Bolt, 3/8"-16 x 2-1/2", gr-5, Zinc Pl  | 39   | 70961   | Cable Return Wear Channel                       |
| 14   | 90296   | Drive Cartridge  | 40   | 70947   | Spring (without pulleys)                        |
| 15   | 10915   | Screw, Self Drilling Phillips #12 x 3/4"   | 41   | 70985   | Synthetic Cable w/ Pulley                       |
| 16   | 70993   | Protective Sleeve  |      | 70795   | Steel Pully 1" Dia. (not shown)                 |
| 17   | 70908   | Grease Zerk  | 42   | 70955   | Center Mounting Bracket                         |
| 18   | 70316   | Adaptor, Motor 2" Alum. Roll Tube  | 43   | 10903   | Lock Washer, 3/8" Zinc Pl                       |
| 19   | 90375   | Bearing, 3/8" x 1/4"   | 44   | 10186   | Nut, 3/8" Hex, Zinc Pl                          |
| 20   | 90313   | Bearing Clip   | 45   | 4000232 | Pivot Mount Wmt.                                |
| 21   | 90378   | Bearing Shaft  | 46   | 90616   | Pivot Mount Bracket (small half)                |
| 22   | 90394   | Lower Pivot Arm Asm  | 47   | 60642   | Bolt, Hex, 3/8" x 1-3/4" Gr-5, Zinc Pl          |
| 23   | 70696   | 1-1/4" Retaining Ring  | 48   | 10172   | Nut, Square 3/8", Zinc Pl                       |
| 24   | 70724   | Washer, Pivot, SST   | 49   | 90803   | Pivot Mount Support Plate                       |
| 25   | 70971   | Wear Bushing, Clip-in  | 50   | 90607   | Dual Pole Mount Kit                             |
|      |         |  |      | 90395   | Tarp Motor Wire Asm (not shown)                 |

**NOTE: Some components are pre-assembled at the factory prior to shipping. The exploded diagram above is for reference purposes and does not display parts in pre-assembled form. Always keep electric conversion parts in proper operating condition. In the event replacement parts are needed, use only genuine Agri-Cover, Inc. replacement parts.**

# ROLTEC® ELECTRIC TARP CONVERSION PARTS DIAGRAM

(For EZ-LOC® 2 inch aluminum tube)

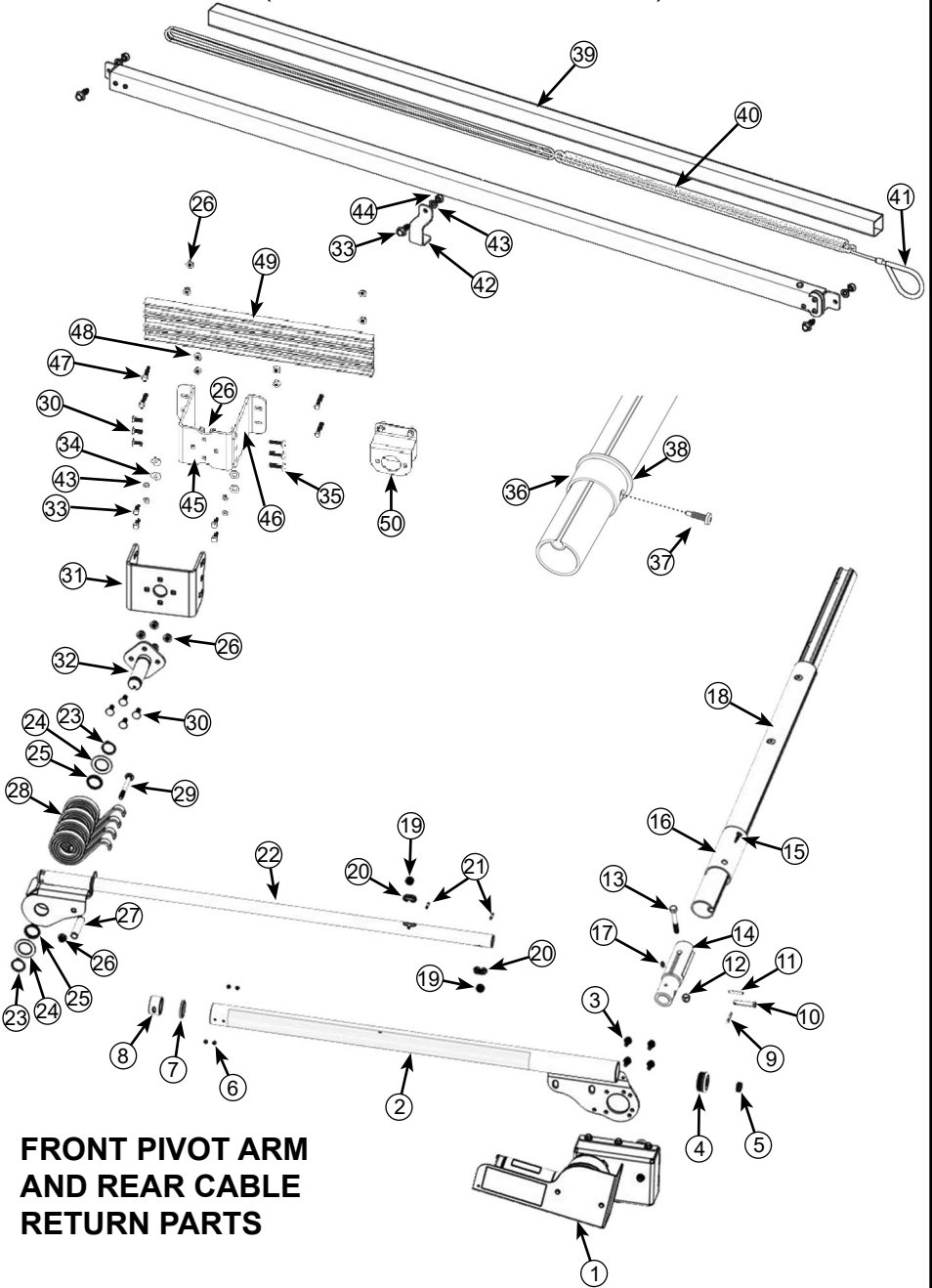

**FRONT PIVOT ARM  
AND REAR CABLE  
RETURN PARTS**

## Part Numbers and Descriptions

(Item numbers are used to reference parts in diagrams throughout this manual)

| Item | Part # | Description  |
|------|--------|--|
|      | 70476  | Rocker Switch 12V Kit (Includes Switch, 10 ft. of 14 Ga. Wire, Solenoid & Related Hardware)<br>Excludes Automatic Breaker & 6 Ga. Wire |
| 51   | 40649  | Rocker Switch 12V  |
| 52   | 40673  | Switch Mounting Bracket  |
| 53   | 40653  | Wire, 3 Conductor 14 Ga. (Requires 10 Lin. Ft. from Switch to Cab)   |
| 54   | 70428  | Terminal, Female Push On 14 Ga.  |
| 55   | 10914  | Screw, Self Drilling Phillips #14 x 1"   |
|      | 40664  | 7/16" ID Rubber Grommet (for 14 Ga. Wire Through Cab) Not Shown  |
| 56   | 60598  | Eyelet Terminal Ring 6 Ga 5/16" (for motor)  |
| 57   | 80334  | Eyelet Terminal Ring 6 Ga. #10 (for automatic breaker)   |
| 58   | 60543  | Eyelet Terminal Ring 6 Ga. 1/2" (for + battery)  |
| 59   | 60570  | Eyelet Terminal Ring 6 Ga. 3/8" (for - battery)  |
| 60   | 70446  | Eyelet Terminal Ring 14 Ga. 1/4" (for Solenoid)  |
| 61   | 70278  | Terminal Boots, Lug Type 8-2 Ga.   |
| 62   | 30649  | Heat Shrink Kit 10 Pcs.  |
|      | 10867  | Cable Tie, 11" Long Black (Not Shown)  |
| 63   | 70498  | Solenoid, Motor Reversing 12V w/ Jump Wire   |
| 64   | 10739  | Circuit Breaker Automatic 12V 40 Amp   |
| 65   | 30648  | Breaker Cover, Rubber  |
| 66   | 70298  | Screw, Self Drilling Phillips #10 x 1"   |
| 67   | 60768  | 4 Ga. 2 Strand (34' supplied)(39" supplied for wireless kits only)   |
| 68   | 70491  | Jump Wire  |
| 69   | 40918  | Dual Pole Connector Socket & Plug Kit (200 Amp) includes bolts, washer, and nuts   |
| 70   | 80006  | Washer, Flat #10   |

**Always keep electric conversion parts in proper operating condition. In the event replacement parts are needed, use only genuine Agri-Cover, Inc. replacement parts.**

# ROLTEC® ELECTRIC TARP CONVERSION PARTS DIAGRAM

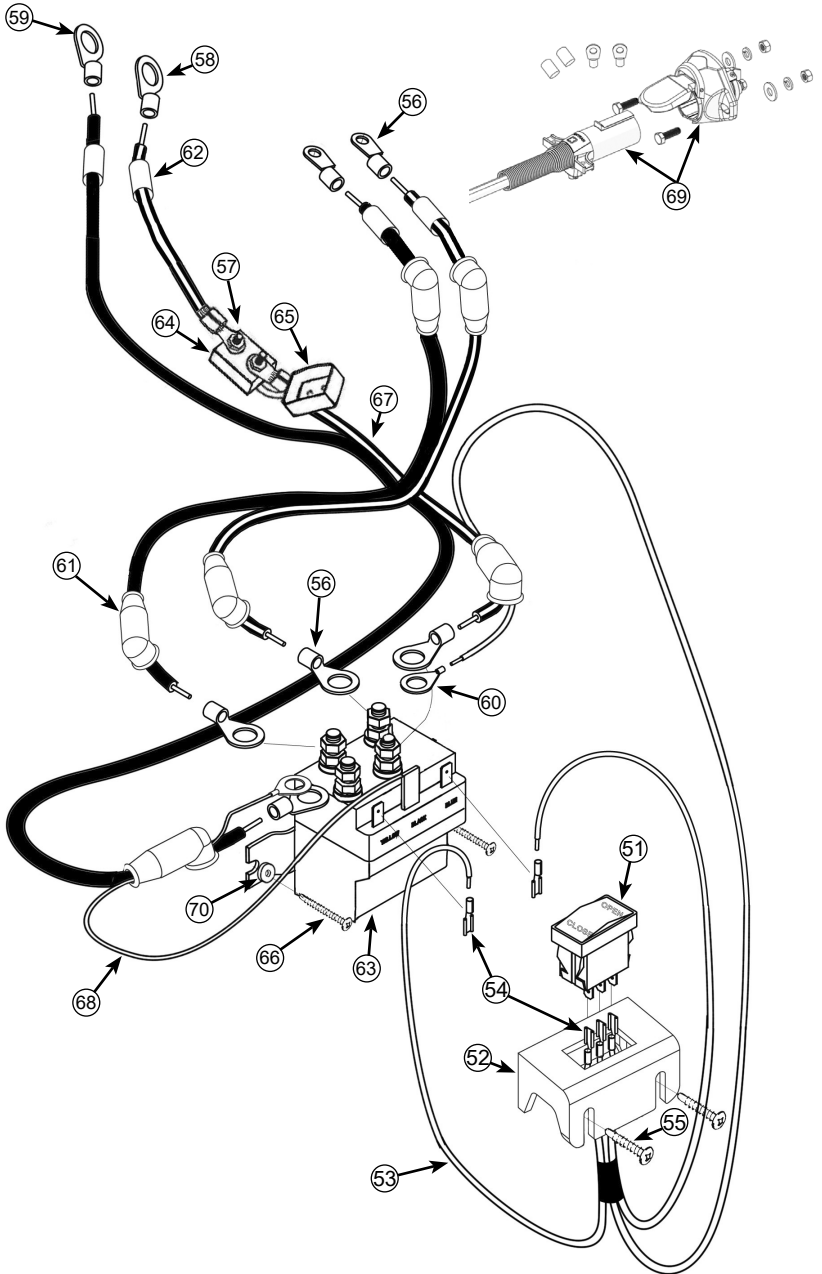

# 1. INSTALLING PIVOT MOUNT - Front of trailer

**TIP:** For easier installation, park trailer on level grade and unhook tractor.

**NOTE:** If installing pivot mount on a slant wall trailer skip step 1A and proceed to step 1B.

**A.** Secure both halves of pivot mount with (3) 3/8" x 1-1/2" carriage bolts and 3/8" nuts.

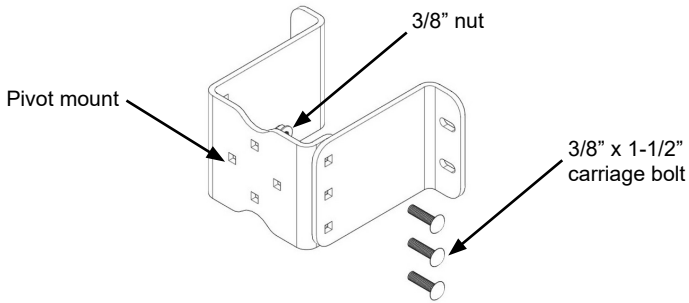

**B.** Slide stainless steel square nuts into channels on support plate. Secure pivot mount to support plate using (4) 3/8" x 1" bolts, flat washers and lock washers threaded into the square nuts in the channel. **Center pivot mount on support bracket and finger tighten all hardware.**

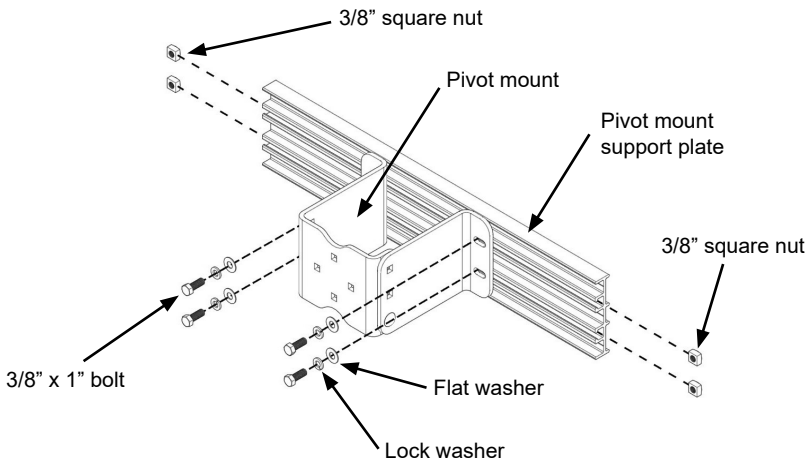

## 2. PIVOT MOUNT/SUPPORT PLATE LOCATION - Front of trailer

At front of trailer align center point of pivot mount support plate with centerline of box. Measure down 47"-55" from top of end cap and mark holes for drilling. View shows vertical wall box. Do the same on slant wall box (see bottom of page). If unable to place at recommended location, pivot mount can be located higher on the box, though arm may lift tarp off box during operation. Make sure telescopic arm has a clear pathway to operate  
**NOTE: Pivot mount support plate should be attached to support braces whenever possible.**

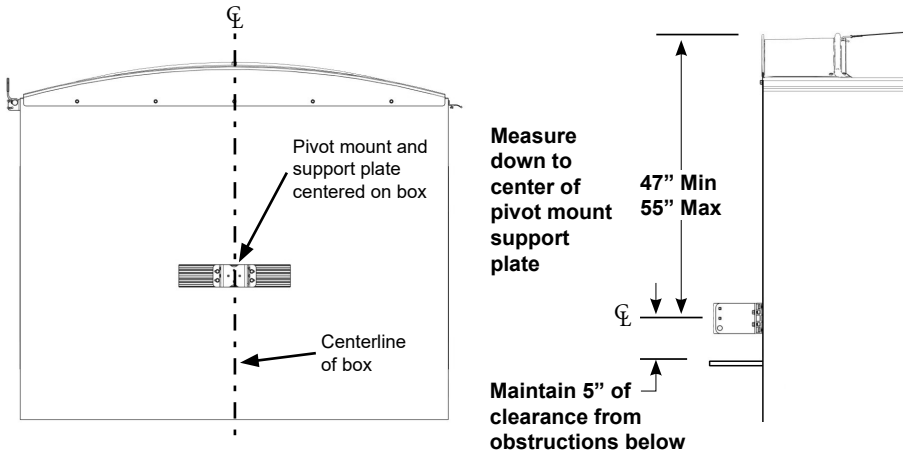

Use the following instructions for installation on a slant wall trailer.

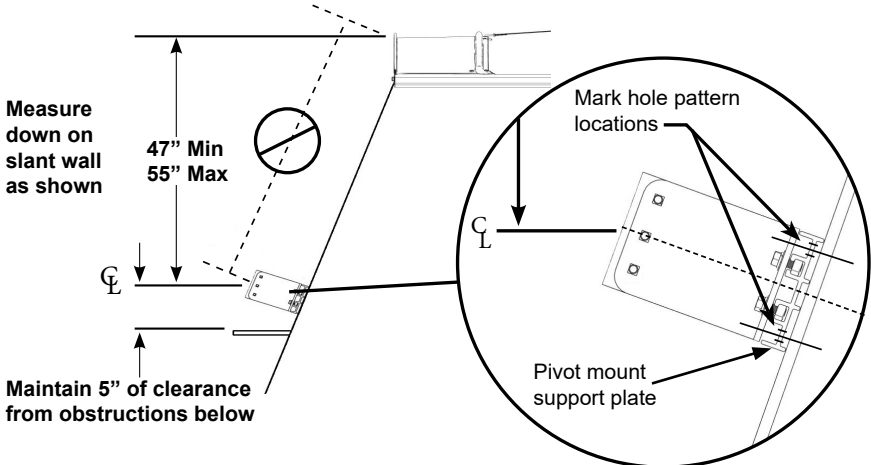

**TIP: Hold pivot mount support plate in position with centerline and mark hole locations in line with support braces using grooves on support plate as guide. Note, on slant wall installs, hole pattern will tilt downward from measured centerline.**

**DO NOT DRILL HOLES YET!**

### 3. INSTALLING SUPPORT PLATE - Front of the Trailer

**Note:** Before drilling any holes, make sure telescopic arm has a clear pathway to operate.

**A.** Drill 5/16" holes where marked. Attach pivot mount support plate to box wall by turning 3/8" x 1" self threading bolts to cut threads then turn back out. Secure using 3/8" x 1-3/4" bolts, whenever possible use nuts on back side.

**NOTE:** Bolt locations may vary from what is shown below based on locations of support braces on trailer.

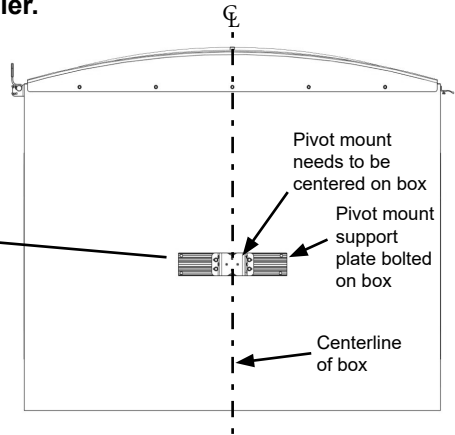
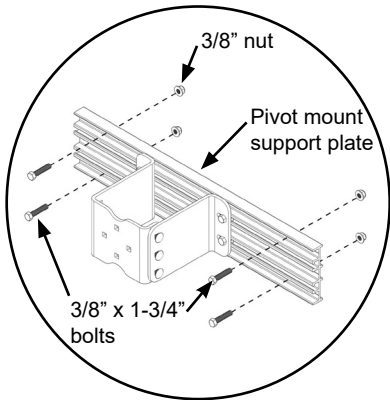

**IMPORTANT:** Before proceeding make sure pivot mount is centered on box. Tighten all hardware at this time.

### 4. BOLTING PIVOT ARM TO PIVOT MOUNT - Vertical Wall

For vertical wall trailer use step 4A, for slant wall trailer use steps 4B and 4C.

**NOTE:** The motor, gear box and arms are pre-assembled. The lower pivot arm slides inside the larger motor arm with wire routed inside both arms.

**A.** Bolt pivot arm to pivot mount using (4) 3/8" x 1" carriage bolts and 3/8" nuts. Make sure keyway in pivot shaft is pointed down. **NOTE:** Carriage bolts may be installed from back side of pivot mount if needed.

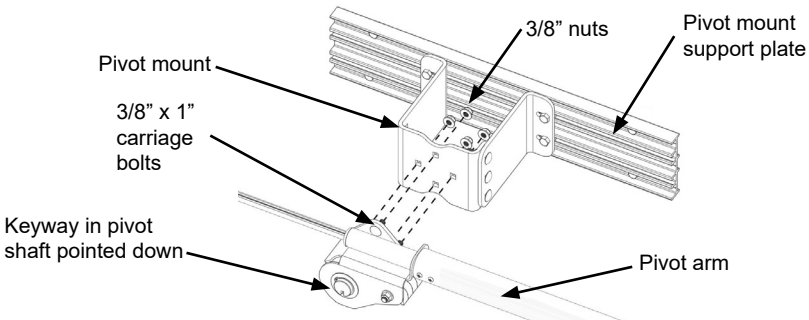

#### 4. BOLTING PIVOT ARM TO PIVOT MOUNT (Continued) - Slant Wall

**B.** Bolt pivot arm to slant bracket using (4) 3/8" x 1" carriage bolts and 3/8" nuts. Make sure keyway in pivot shaft is pointed down and slant bracket has wide side up. **NOTE: Carriage bolts may be installed from backside of pivot mount if needed.**

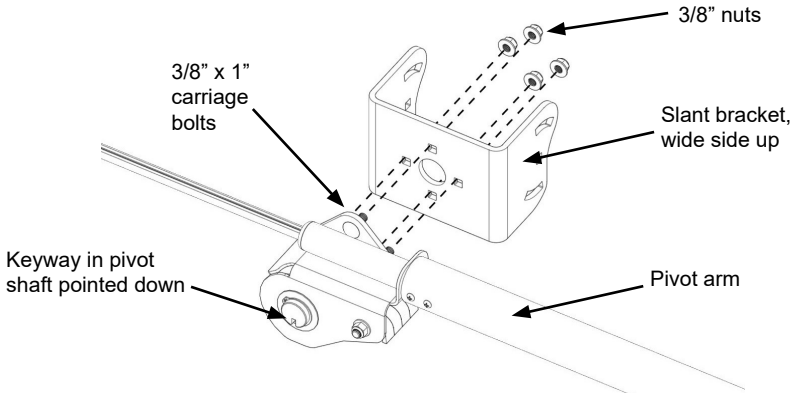

**C.** Bolt pivot arm with slant bracket to pivot mount using (3) 3/8" x 1" carriage bolts, (3) 3/8" x 1-1/2" carriage bolts and 3/8" nuts. Make sure notch in pivot shaft is pointed down and wide side of slant bracket is up. **Leave bolts loose for now.**

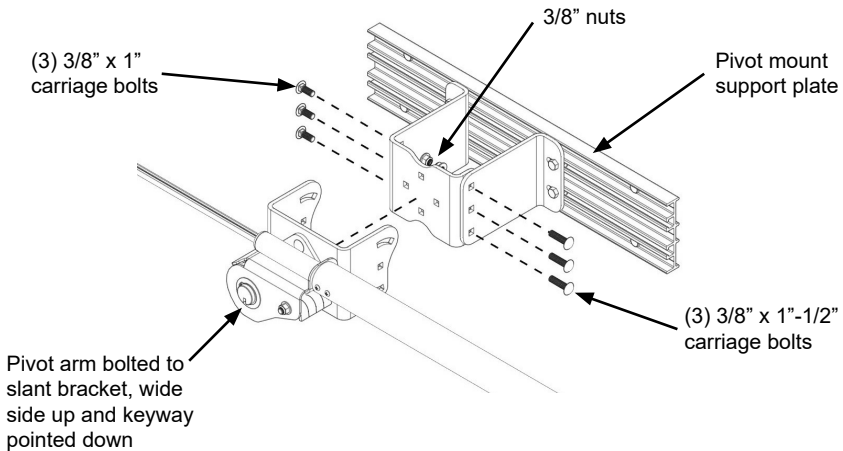

## 5. VERTICAL ALIGNMENT OF MOTOR ARM

**NOTE: Arm is under pressure. Requires two people for safe installation.**

Lift arm to vertically align motor and arm as shown. Make sure pathway of motor and arm is free of obstructions (ladders, etc.). Tighten carriage bolts now.

### Vertical Wall Front

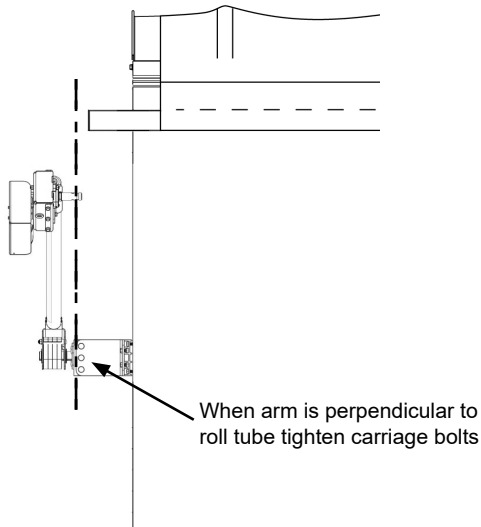

### Slant Wall Front

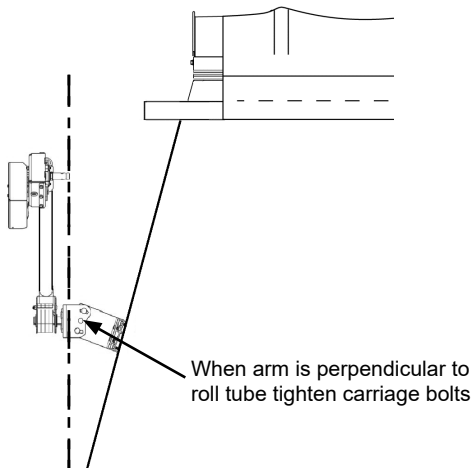

## 6. REMOVING CRANK ASSEMBLY

**NOTE: Remove any existing returns such as cable return, bungee return, etc. at both front and rear.**

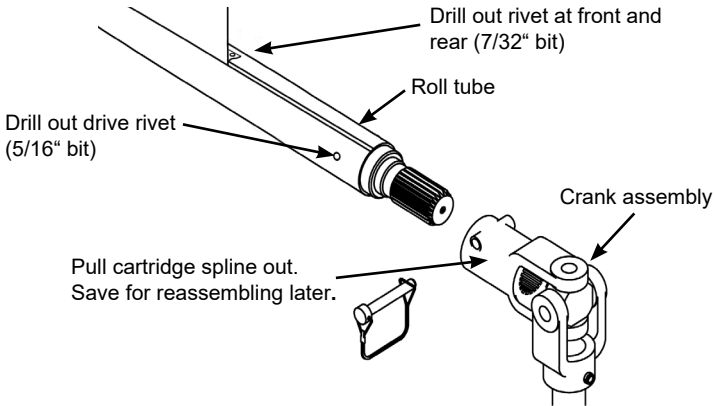

Roll tarp closed over box with roll tube hanging below latch plate. Remove crank assembly from roll tube. Drill out rivet with 5/16" bit and remove spline. Save spline to be re-installed in later step.

## 7. INSTALLING NEW FRONT DRIVE CARTRIDGE

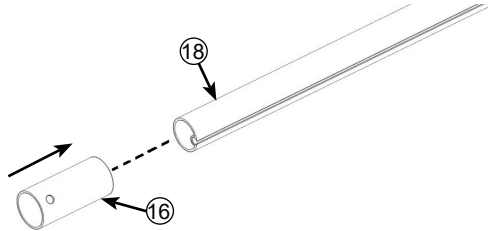

Slide roll tube protector onto roll tube extension, leave loose for final adjustment in step 9.

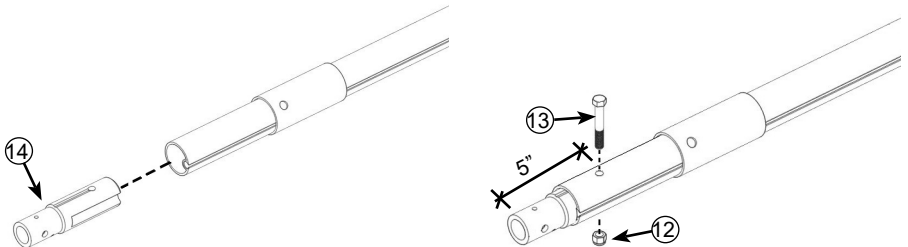

At front of roll tube extension, align large groove on cartridge with groove on roll tube. Use small groove on cartridge as guide to measure 5" from end of cartridge onto roll tube as shown. Mark and drill 13/32" hole through first layer of roll tube. Push cartridge into tube and use hole as guide to drill through other side of roll tube. Insert 3/8" x 2-1/2" both and secure with 3/8" nylock nut.

## 8. ROLL TUBE SPLICE EXTENSION AT FRONT OF TRAILER

A. Pull end of roll tube away from tarp enough to allow drilling holes and welding splice. On existing roll tube mark locations for holes (both sides of rope channel) and drill (4) 5/8" holes (through roll tube only) and deburr when needed. (See figure to right for locations)

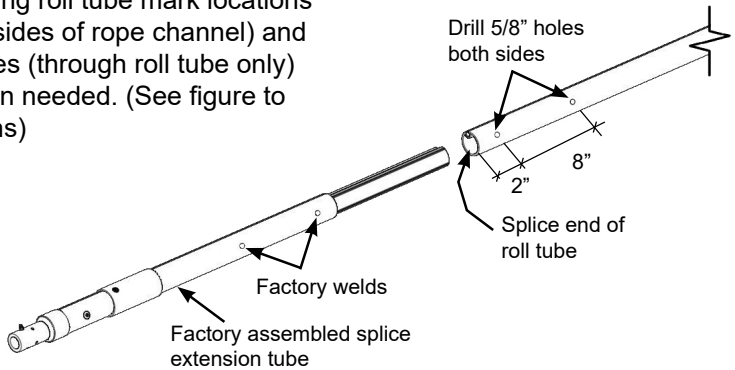

B. Insert splice end of tube extension into roll tube and butt them tight against each other. Secure splice to roll tube and plug each of the 4 holes with an aluminum weld. Let cool and grind welds flush to prevent tarp wear.

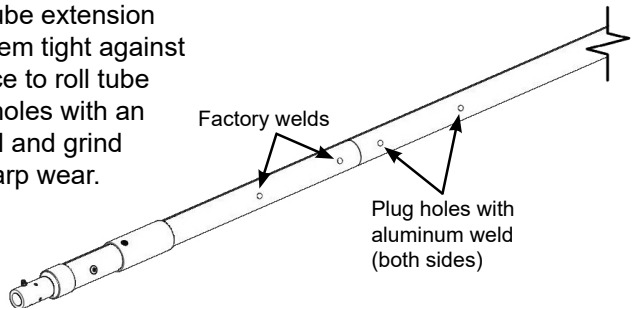

### Alternate Method of Connection

B. This method will replace welding in this step. Insert splice end of tube extension into roll tube and butt them tight against each other. Secure splice and roll tube then drill pilot hole into splice through center of previously drilled 5/8" hole using a 1/8" bit. **IMPORTANT:** Pilot hole needs to be centered in previously drilled holes on roll tube, this will ensure screw heads will not touch sides of the drilled hole. Secure extension by turning (4) 1/4" x 3/4" self tapping Phillips head screws into pilot holes. (See figure below)

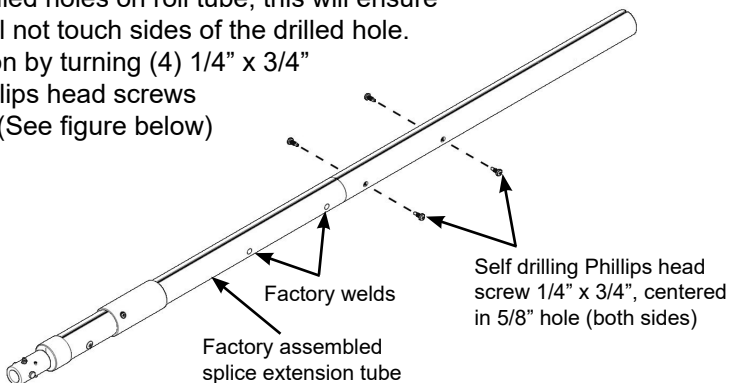

## 9. CONNECTING MOTOR TO ROLL TUBE

**NOTE: Arm is under pressure. Requires two people for safe installation.**

### Front Vertical Wall Trailer

Apply grease to motor shaft. Raise arm with motor up and insert shaft into drive cartridge. Secure shaft to tube with roll pin. Rotate tube as needed to align holes in tube with hole in shaft. Insert clevis pin and cotter key, bend tabs to secure. Align center of sleeve to travel over top of wind deflector. Secure with #12 Phillips head screw.

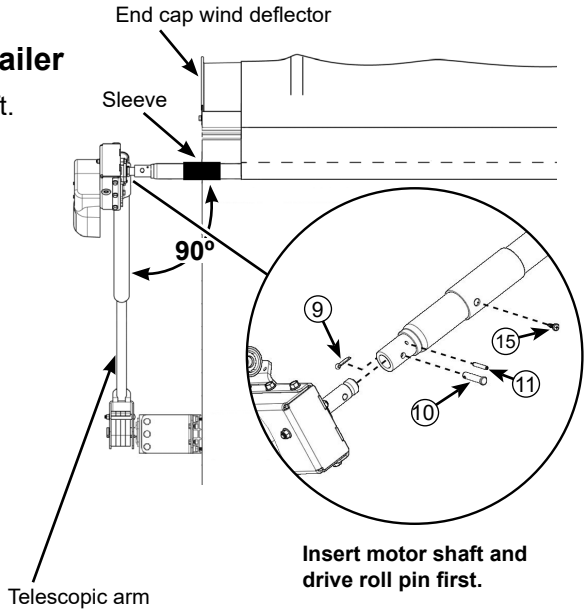

### Front Slant Wall Trailer

Apply grease to motor shaft. Raise arm with motor up and insert shaft into drive cartridge. Secure shaft to tube with roll pin. Rotate tube as needed to align holes in tube with hole in shaft. Insert clevis pin and cotter key, bend tabs to secure. Align center of sleeve to travel over top of wind deflector. Secure with #12 Phillips head screw.

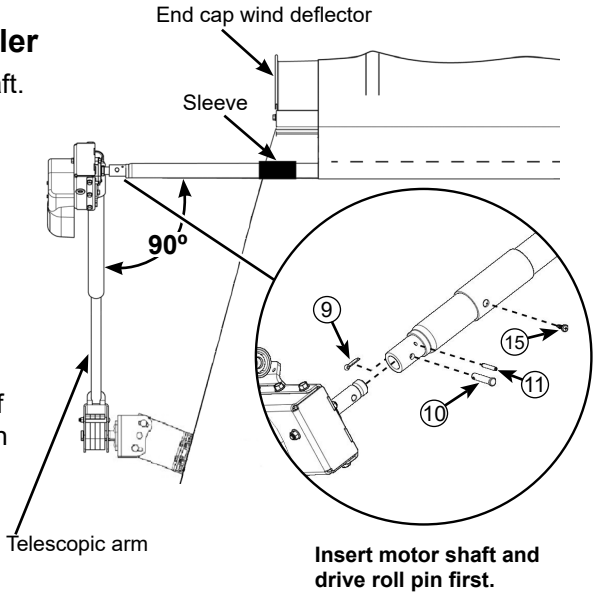

Square the motor pivot arm with roll tube by adjusting the motor and roll tube forward or backwards as needed.

## 10. REATTACH TARP

At front, use existing hole in tarp as guide to drill new 7/32" hole in tube for rivet. Insert drive rivet and set with hammer. At rear, pull tarp tight and use existing hole in tarp as guide to drill new 7/32" hole in tube. Insert drive rivet and set with hammer.

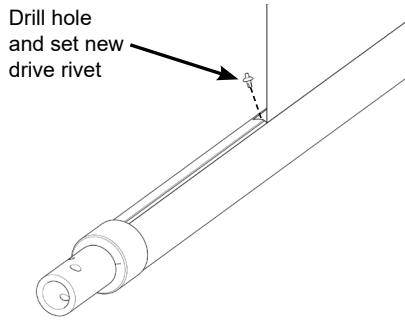

**FRONT**

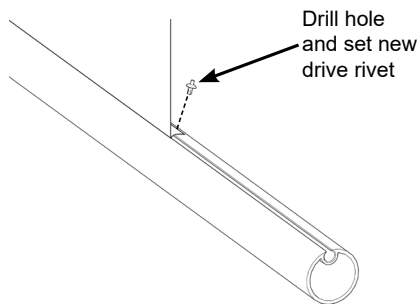

**REAR**

## 11. TRIMMING ROLL TUBE

Measure 3-5" back from end cap as shown and make a mark. Cut off excess roll tube at mark. At existing rear spline, drill out rivet and save spline to be reinstalled in step 13.

### Rear Vertical Wall Trailer

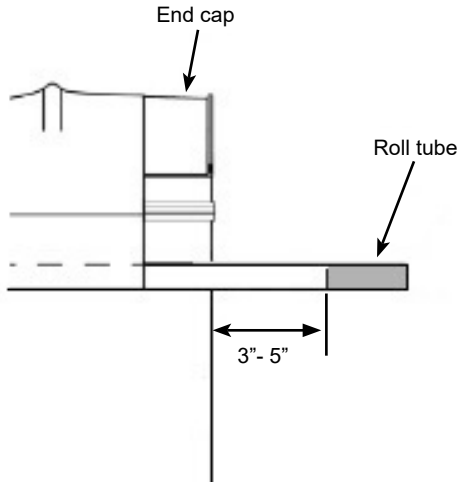

### Rear Slant Wall Trailer

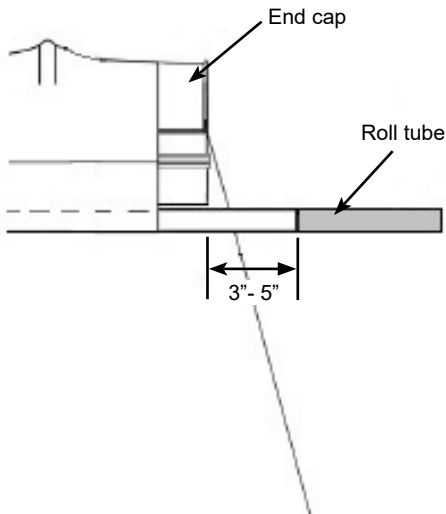

## 12. REAR CABLE RETURN INSTALLATION

Align bottom edge of cable return with top edge of box behind cap. Slide cable return to left until tab meets bottom of hem. **(as shown)**

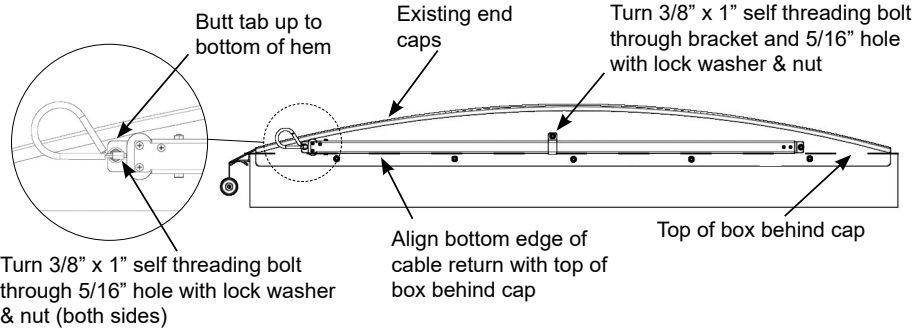

Mark and drill 5/16" holes at mounting tab at each end. Secure cable return with 3/8" x 1" self threading bolts, lock washers, and hex nuts.

Place center mounting bracket (tab up) at center of cable return. Mark and drill 5/16" hole and attach using 3/8" x 1" self threading bolt, lock washer, and nut.

Slide cable return loop, cable retainer, and retaining collar onto roll tube. Use a #14 x 1" self drilling Phillips head screw to secure retaining collar. **Ensure synthetic cable runs unobstructed along entire path of travel.**

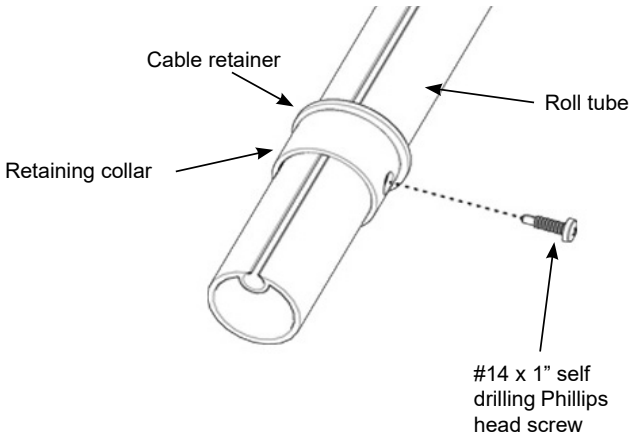

### 13. ATTACHING SPLINE AT REAR

At rear of roll tube, align large groove on cartridge with groove on roll tube. Use small groove on cartridge as guide to measure 1-5/16" straight in from edge of roll tube. Mark and drill 7/16" hole through first layer of roll tube. Push cartridge into tube and use as guide to drill through other side of roll tube. Slide cable retainer onto roll tube and insert 3/8" x 2-1/2" bolt and secure with 3/8" nylock nut.

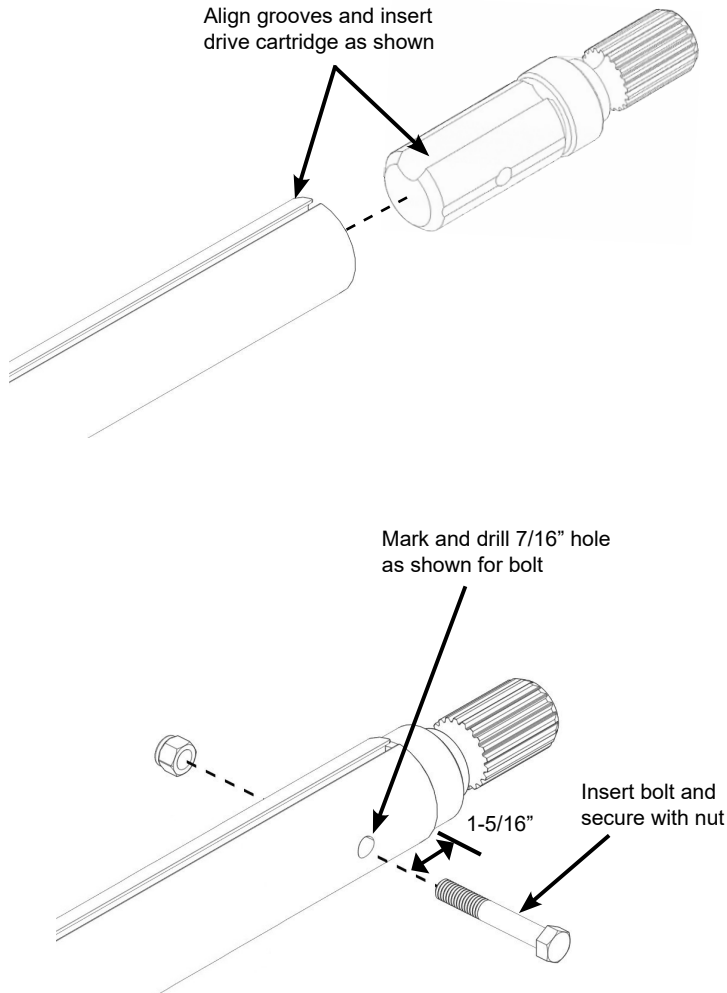

## 14. INSTALLING CONNECTOR SOCKET

**TIP: Dielectric silicone is provided for electric wire connections. Use as needed.**

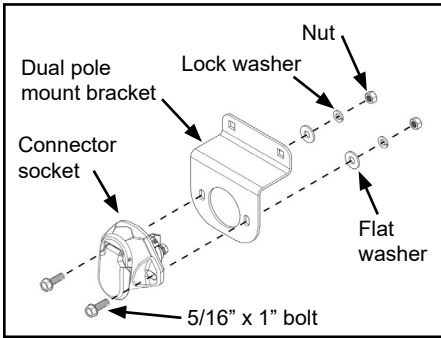

**A.** Bolt connector socket to dual pole mount bracket using 5/16" x 1" bolts, flat washers, lock washers and nuts.

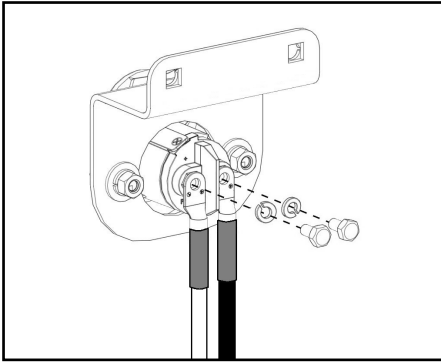

**B.** Before cutting wire, form a loop on arm that allows room for movement and mark where to cut at socket connector at location on dual pole mount bracket. Cut wire, strip only enough insulation off to attach ring terminals and heat shrink tube. Attach wires to socket terminals.

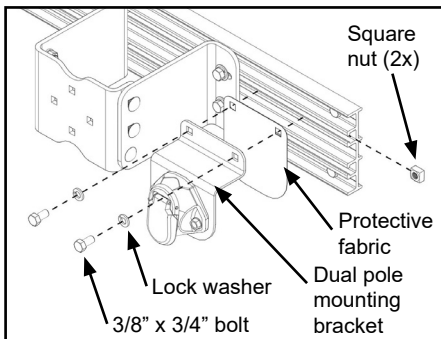
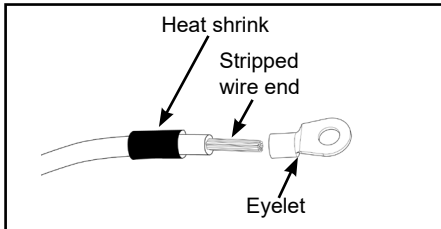

**C.** Slide (2) square nuts into channel on pivot mount. Place protective fabric between dual pole mounting bracket and pivot mount and secure dual pole mounting bracket with 3/8" x 3/4" bolts and lock washers.

## 15. WIRING ELECTRIC CONVERSION

**NOTE:** If installing an optional tarp control box, skip steps 14-15. Use instructions supplied with the tarp control box.

**TIP:** Dielectric silicone is provided for electric wire connections. Use as needed.

### A. WIRE ROUTING - HEAVY GAUGE

Select best routing of wire from battery to solenoid usually along frame with other wire harness along cab and up to pole connectors.

**ATTENTION:** If installing this kit on an existing tarp system, it is recommended both end tarp stops are located 5" in from each end of tarp. When needed and if possible, relocate existing end tarp stops.

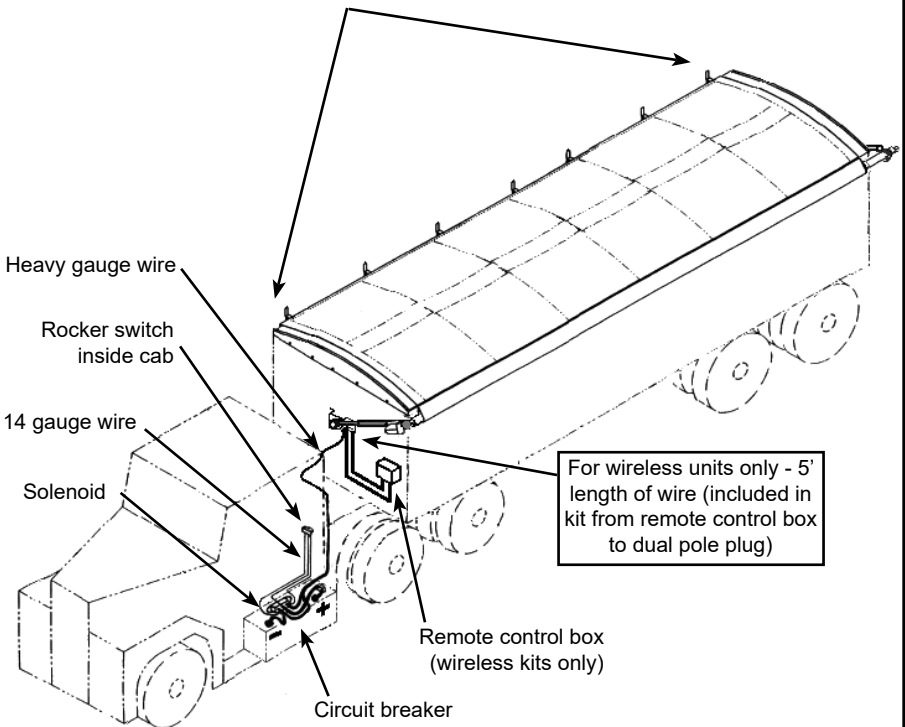

**NOTE:** Some wiring will come pre-assembled.

## 16. WIRING SWITCH

### B. SWITCH LOCATION AND INSTALLATION

Select convenient location in cab to mount switch bracket with two #14 x 1" self drilling Phillips screws through slots in back of bracket.

Route 14 ga. wire from switch to location of solenoid near battery. Rubber grommet is supplied for area where wire enters cab, 11/16" hole is needed for grommet.

At switch, strip 14 ga. wire ends about 3/8" back and attach push-on connectors and crimp. Pull wires through mount bracket and attach to switch. Snap switch into mount bracket.

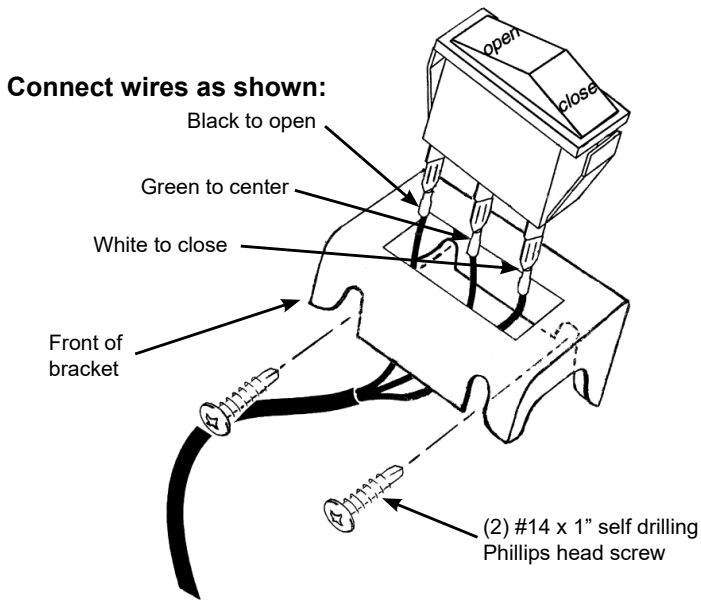

### C. SOLENOID

Mount solenoid in protected area near battery using #2 x 1" self drilling Phillips screws. Then follow wiring connections on page 21. For reference see wiring schematic on page 22.

### D. LIGHT GAUGE WIRES

Prepare end of black and white light gauge wires from switch with push on connectors for solenoid terminals. Connect white wire to close terminal. Connect black wire to open terminal. Prepare end of light gauge green wire from switch with 1/4" ring terminal. For reference see wiring schematic on page 22.

## 16. WIRING SWITCH (Continued)

### E. HEAVY GAUGE WIRES

Split heavy gauge wire at solenoid about 4" back. Prep ends of black and red heavy gauge wires leading from motor and battery with heavy gauge 1/4" ring terminals, heat shrink tubes and rubber boots for (4) solenoid studs if needed. Attach wires to solenoid studs as shown on wiring schematic on page 22. Note the light gauge jump wire leads through same rubber boot with black (-) wire from battery. The green wire from the switch leads through the same rubber boot with red (+) wire from battery. Tighten nuts on terminal - always hold base nut while tightening top nut. Do not over tighten. Connect the white light gauge wire to close terminal and black wire to open terminal (see wiring schematic on page 22).

### F. CIRCUIT BREAKER

Install circuit breaker in line on red (+) wire close to battery using #10 ring terminals and heat shrink. **(Prep wires as shown)**

1/2" ring terminal for (+) battery post  
3/8" ring terminal for (-) battery post  
#10 ring terminals for circuit breaker  
1/4" ring terminals for solenoid and motor terminals

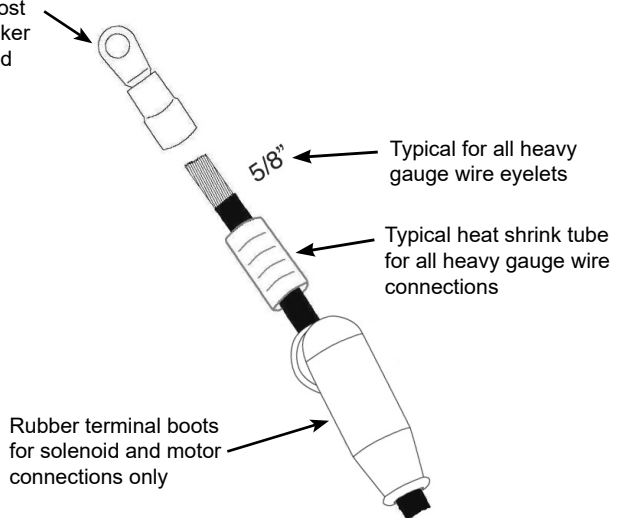

### G. BATTERY

Prep end of heavy gauge black wire for battery (-) post with heat shrink tube and 3/8" ring terminal. Prep end of heavy gauge red wire for battery (+) post with heat shrink tube and 1/2" ring terminal. **Connect wires to battery now.**

**NOTE:** Once all wiring is completed, verify system according to schematic. Inspect travel paths of arms at front and rear to ensure no interference. Make adjustments if needed. Test operation. If motor runs tarp in reverse of open and close positions on switch, reverse 14 gauge wires on solenoid (move white to 3 and black to 1).

# WIRING SCHEMATIC DIAGRAM

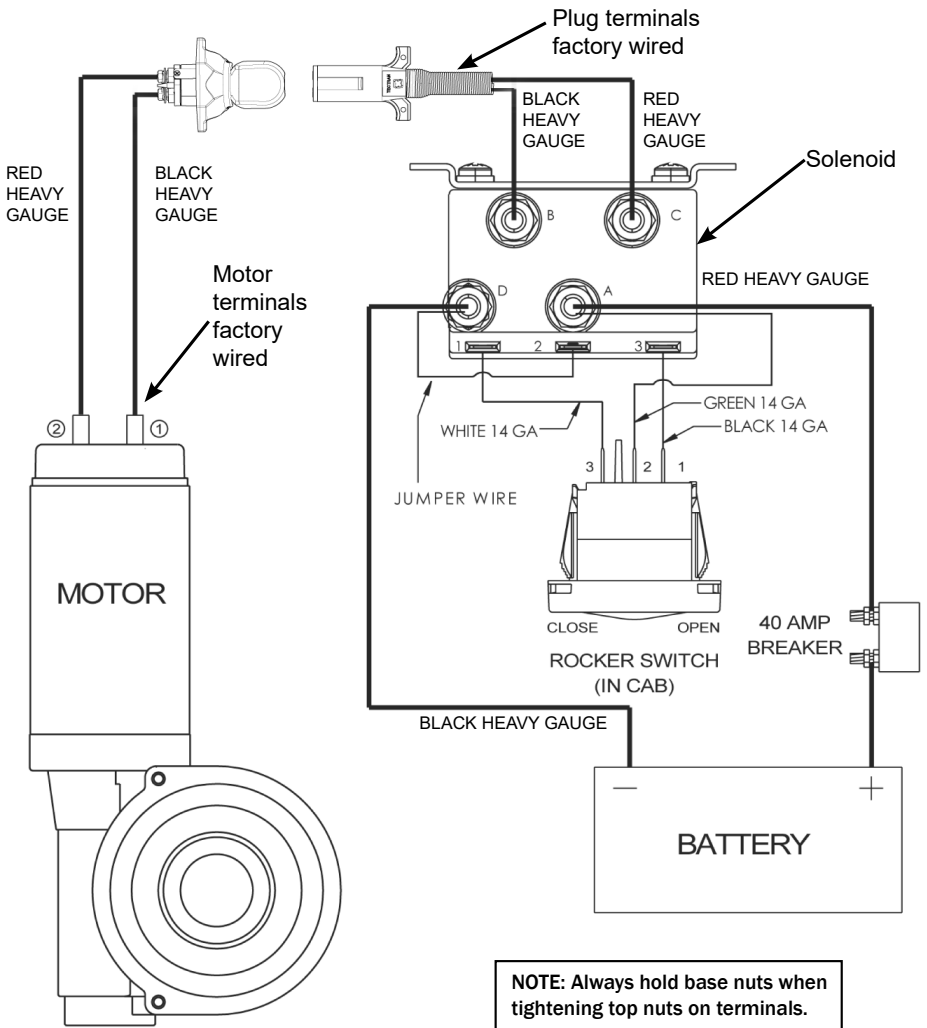

## 17. OPTIONAL EDGE TRIM

**NOTE:** Some tall wind deflectors may cause increased friction and slightly reduce return spring function. For smooth return operation, trim air dam as needed. For tall air dams, end caps without hem or end caps that were trimmed; apply edge trim onto edge of front air dam from latch plate towards middle of air dam. Edge trim will not cover entire end cap. Repeat at rear end cap.

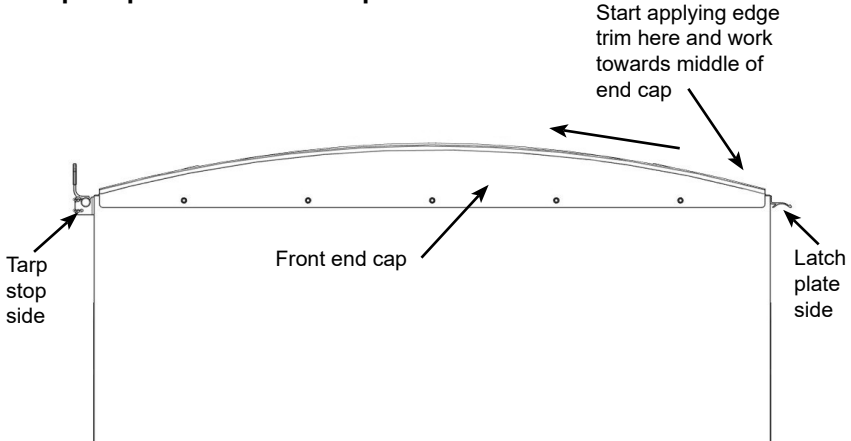

## ENABLE MANUAL OVERRIDE

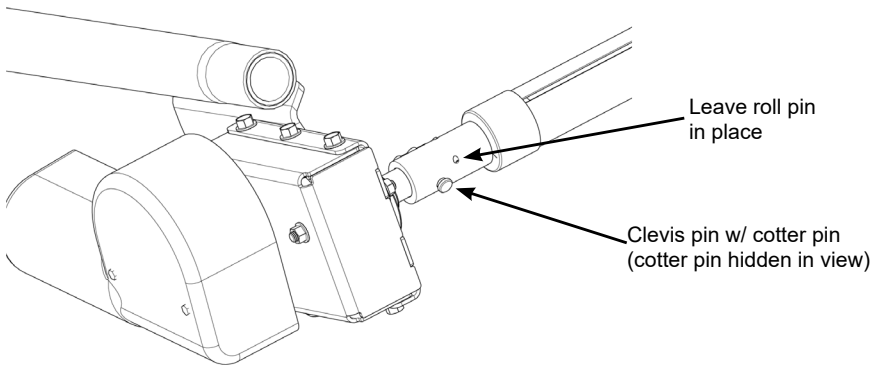

To enable manual override, disconnect power, relieve pressure on clevis pin and remove while making certain roll pin is in place.



**CAUTION** If attaching crank handle, **ALWAYS** remove it before connecting power back to tarp motor.

# MANUFACTURER'S LIMITED WARRANTY

Agri-Cover, Inc. extends the following limited warranty on its ROLTEC® Electric Tarp Conversion to the original retail purchaser:

Agri-Cover, Inc. warrants its ROLTEC® Electric Tarp Conversion to be free from defects in material and workmanship under normal use for one (1) year from date of manufacture unless accompanied by proof of purchase. The one (1) year warranty start date can be found on the unit (motor and gearbox). Check both and refer to the oldest date shown.

ANY IMPLIED WARRANTY APPLICABLE TO THE ROLTEC® ELECTRIC TARP CONVERSION IS LIMITED IN DURATION TO ONE YEAR FROM THE DATE OF MANUFACTURE UNLESS ACCOMPANIED BY PROOF OF PURCHASE. Agri-Cover, Inc.'s sole obligation under this warranty or any implied warranty is limited to the repair or replacement at its option, of defective parts only. No labor or service allowance is given or implied. IN NO EVENT SHALL AGRI-COVER, INC. BE LIABLE FOR INCIDENTAL, CONSEQUENTIAL, OR SPECIAL DAMAGES. Some states do not allow limitations on how long an implied warranty lasts or exclusions of incidental or consequential damages, so the above limitations and exclusions may not apply to you.

For warranty call our Customer Service Department at 800-233-4655 to determine if only a replacement part is needed or if the cover needs to be returned for inspection and repair. Goods to be returned must have a pre-authorized RA# (Returned Authorization Number) – obtained by calling the number above. Mark the number on the package and ship it freight prepaid to address below. Agri-Cover will pay freight to return goods to sender.

This warranty does not cover any failure due to abuse, misuse, alteration, neglect, improper assembly or installation, or improper maintenance.

This warranty gives you specific legal rights and you may have other rights which vary from state to state.



Agri-Cover, Inc.  
Customer Service Dept  
PO Box 508 | 3000 Hwy 281 SE  
Jamestown, ND 58402  
Phone: 800-233-4655

**Hours: 8:00 am - 5:00 pm CST Monday through Friday, except Holidays**  
ROLTEC® is a registered United States trademark of AGRI-COVER, INC.