



# STAKE POCKET INSTRUCTIONS FOR FORD F150

**NOTE TO INSTALLER: BEFORE ATTEMPTING TO INSTALL ADARAC RAILS, USE THESE INSTRUCTIONS TO LOCATE FRONT AND REAR STAKE POCKETS, TRIM CUT THEM OPEN. THEN USE ADARAC OWNERS MANUAL FOR REMAINING INSTALLATION.**

**Tools needed: Protective Eyewear, Tape Measure, Marking pencil, Drill with 1/2" bit and a Utility Knife**

## 1 LOCATING CONCEALED STAKE POCKET TO CUT OPENING

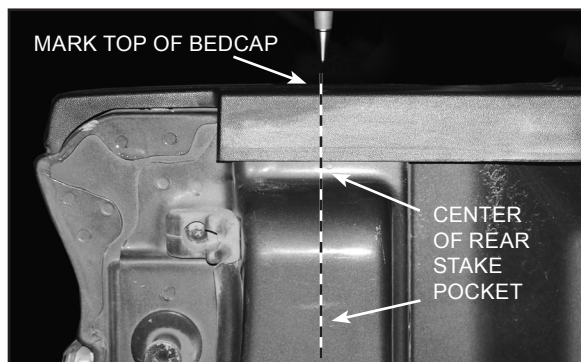

Illustration 1

On inside of box, locate center of stake pocket column and use it as guide to make a line marking center of stake pocket column on top of nylon bed cap. View shown is of rear stake pocket. (Illustration 1 and 2)

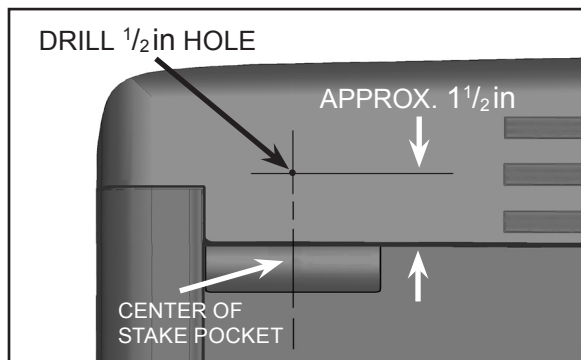

Illustration 2

B. On top of nylon bed cap, measure approximately 1 1/2 inches from inside edge of box and make another line that intersects with first center line. Drill a 1/2 inch hole through bed cap where lines intersect. (Illustration 2)

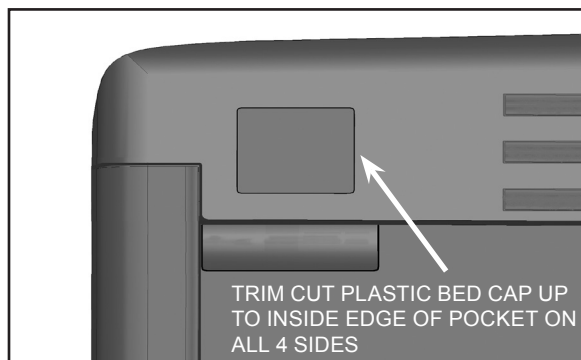

Illustration 3

Then make a series of cuts working out towards edge on all 4 sides until finding steel stake pocket. Trim away nylon all along sides of steel pocket. Repeat Step 1 at remaining rear and front stake pockets. (Illustration 3)