



08-Newer Dodge Dakota with Cargo Rails

Instructions to Mount Cover Side Rails

TOOLS: 10 MM Socket/Short Extension & Ratchet, T25 Torx, Tape, 3 MM Allen Wrench, Inch Pound Torque Wrench, Protective Eyewear

NOTICE to Installer: Use these instructions in place of the side rail instructions in the Owner's Manual. Use owner's manual for remaining cover installation. When done, keep these instructions with the Owner's Manual.



- 1 Remove hex head bolts from cargo rail. (passenger side shown) Use 10MM wrench and save bolts for later.

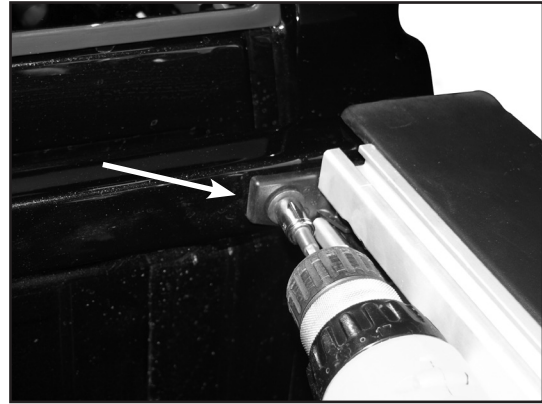

- 2 Remove bolt at front corner of box. Save for later.



- 3 At rear, gently lift up on bed cap to separate double backed tape from box.



- 4 Lift up slightly and pull on cargo rail until nylon body fastener is loose, then remove rail from box.



- 5 Remove star head bolts that hold bed cap to cargo rail. (these bolts will not be re-used)



- 6 Replace star head bolts with Allen head bolts from kit. **Leave these bolts loose for now.**



- 7 Position cover side rail **in between** cargo rail and bed cap.

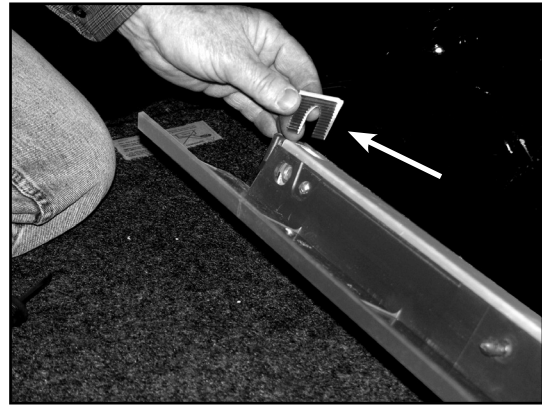

- 8 Insert a shim at each 10MM bolt location excluding the one at rear. (See Step 9 and 10 for positioning and quantity of shims.)

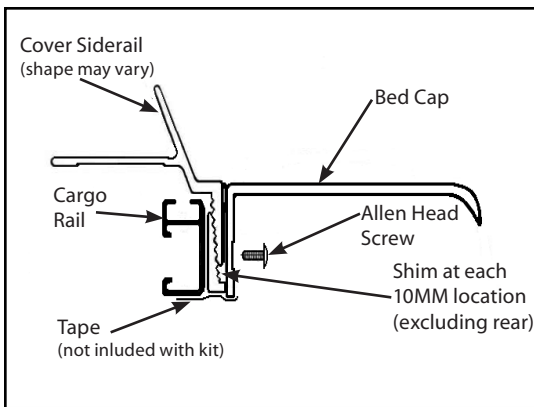

- 9 Place each shim in assembly as shown. Applying small piece of tape at bottom will hold shims in place later when mounting assembly back on box.

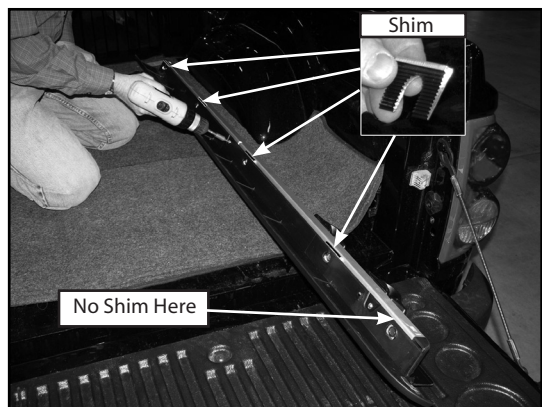

- 10 Tighten Allen head screws to hold cargo rail, shims, cover rail and bed cap together as an assembly.

NOTE: For 5'-4" long bed use 4 shims per side. For 6'-6" long bed use 5 shims per side.

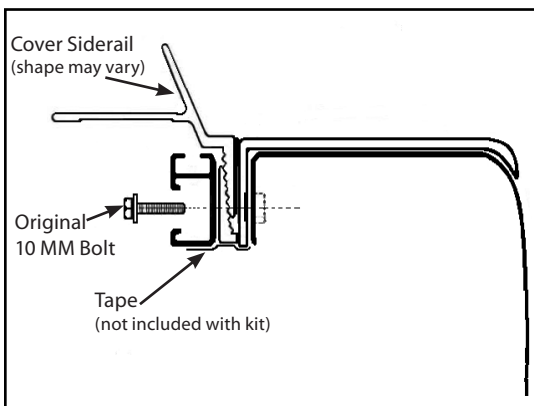

- 11 Set entire assembly back on box. Align holes to turn original 10mm bolts back in. Press down on bed cap at rear to make double back tape reattach to body.

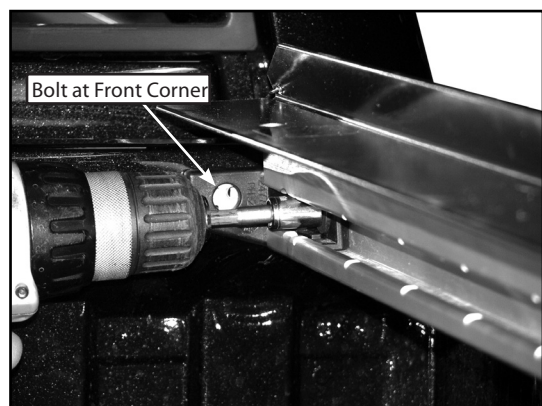

- 12 Push cover rail forward against front of box. Turn singles bolt at front corner in. Tighten all 10MM bolts including the one at front of box. Torque set them 70 inch lbs. Remove tape under shims. Repeat procedure for driver side rail.