

ROLL-UP COVER™



INSTALLATION INSTRUCTIONS & OWNER'S MANUAL COVER #124 (for on 01–03 F150 Super Crew and 04 Heritage Super Crew)

Thank you for purchasing a Roll-Up Cover™. ACI has manufactured this roll-up cover with pride using superior quality materials and craftsmanship. With proper care, your cover will provide years of service and enjoyment.

NOTICE TO INSTALLER: It is recommended you take the time to read these instructions before installing this cover even if already familiar with the product. Often improvements are made without prior notice. Always handle cover and components with care to avoid damage. If you find a part missing or defective, or if you are having trouble installing this product, please have serial number ready (found on decal under rear bar by tailgate) and call the customer service number on the back page. **When done, these instructions and warranty information must be given to the consumer.**

NOTICE TO CONSUMER: Before using this product, read the operating instructions, maintenance and safety sections of this owners manual and save for future reference.

FOR YOUR RECORDS:

DATE PURCHASED _____

WHERE PURCHASED _____

SERIAL NUMBER _____

(Located on decal under rear bar by tailgate)

WARRANTY REGISTRATION

Product must be registered to validate the warranty. Go online to www.agricover.com/productregistration or complete the registration form on Page 11.

HELP LINE



Call Customer Service:
(701) 251-1427
www.accesscover.com/faq

Tested. Trusted. Guaranteed.

INSTALLATION INSTRUCTIONS:

(NOTE: For additional installation assistance go online to accesscover.com instruction manual and click on installation video.)

PREPARATION



Unpack cover components.
Clean truck box if dirty.

COMPONENTS:

- 1 driver side rail
- 1 passenger side rail
- 1 element seal kit
- 8 clamps
- 1 left and 1 right tension adjuster with nuts & bolts
- 1 pre-rolled up cover assembly

TOOLS NEEDED:

- 1 - 1/2" wrench (for rail clamps)
- 2 - WR7 vise-grip pliers (to hold rails in place while clamping)
- 1 - Tape measure or ruler
- 1 - Scissor
- 2 - 9/16" wrenches
- Another person to assist
- Protective eyewear

NOTE ON BED LINERS: With an under-the-rail drop in bed liner, installation is possible with minimal trim cutting of bed liner at front corner of box and back by tailgate to allow side rail to install properly. Considerable trim cutting is required with an over-the-rail drop in bed liner.

1: INSTALLING COVER SIDE RAILS

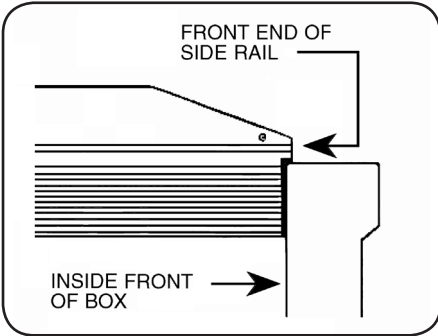

A. Position side rail with weather strip against inside lip of box. **Push rail forward until it touches front of box.** End of rail with strike goes to rear.

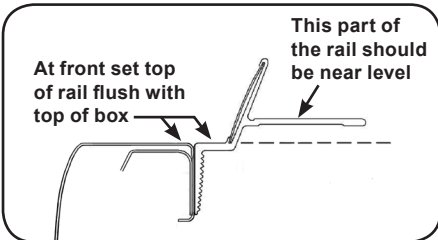

B. At front, adjust top of rail flush with top of box. Then secure front of rail to box with vise-grip as shown in **WISE-GRIP SEQUENCE** diagram on next page.

1: INSTALLING COVER SIDE RAILS CONT'D.

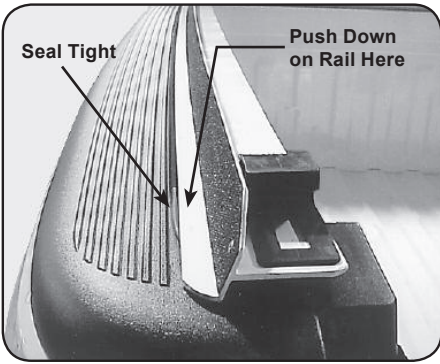

C. At rear of box, rail will set on top. **Push down firmly on rear of rail until weather seal is compressed tight to top of box. Then secure rear of rail with vise-grip.**

D. Start at front of box. Install 1st clamp 1-1/2" from inside of box. See number (3) in diagram below.

IMPORTANT TO KEEP RAIL ON TRUCK SECURELY: Before using wrench on clamp, make sure clamp teeth engage grooves on rail, turn nut finger tight and then use wrench.

Follow **CLAMPING SEQUENCE** below for remaining clamps. Repeat entire installation procedure for rail on opposite side. When done make sure all clamps are fully tight on both rails.

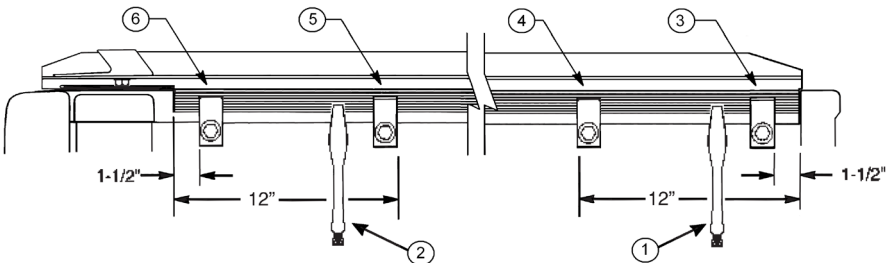
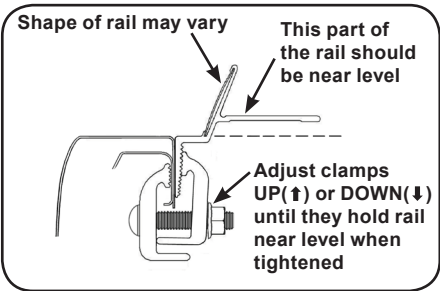

- ① Vise-Grip at front
- ② Vise-Grip at rear
- ③ Clamp at front
- ④ Clamp at front
- ⑤ Clamp at rear
- ⑥ Clamp at rear

NOTE: Always install all 4 clamps on each side rail even if you have to move them closer together.

WISE-GRIP AND CLAMPING SEQUENCE

2. ASSEMBLING TENSION ADJUSTERS TO COVER

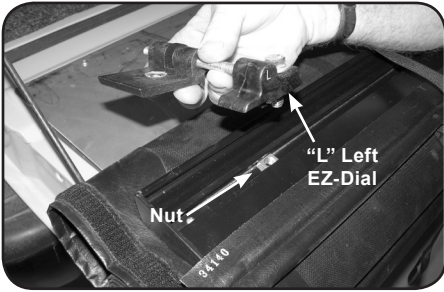

A. The cover comes pre-rolled to its normal open position for ease of installation. Set pre-rolled cover on tailgate with front bar facing up as shown. Align EZ-Dial Tension Adjuster (marked "L") on driver side of cover—positioned as shown in photo at left.

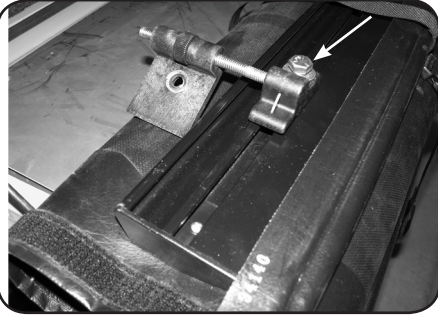

B. Turn 1-1/4" bolt with flat washer onto nut in bar. Leave loose for now. See photo. Repeat for EZ-Dial ("R") on passenger side of cover, and leave that bolt loose also.

3. MOUNTING COVER TO SIDE RAILS



A. Set rolled up cover on rails at front of box (behind cab) with bar facing up. Roll cover bar onto front of side rails and fold/touch vinyl flap under. Now bar will face down. Let straps hang to inside of box. Push cover bar forward until it sets flat on front of side rails and overhangs them.



B. Slide left tension adjuster over until it engages under side rail. (See photo in Step 3 E for tension adjuster tab under side rail.) Push bar back and forth to line up holes—do not turn dial wheel. Insert bolt from top and nut from bottom.

3. MOUNTING COVER TO SIDE RAILS CONT'D



C. Hold bolt at top and tighten nut under side rail. Repeat procedure for right hand tension adjuster.

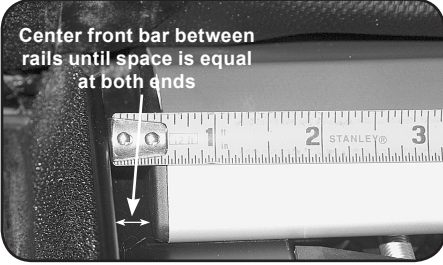

D. Center the front bar between the two side rails.

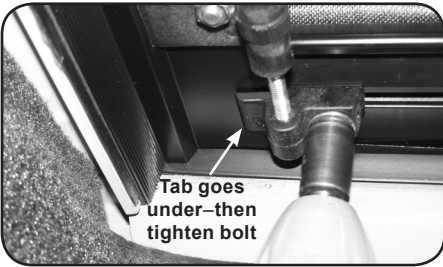

E. Then tighten bolt (left loose earlier) under front bar on each tension adjuster.

4. INITIAL OPERATION AND ADJUSTMENTS



A. Unroll cover and place rear bar into strikes on side rails. Press down on bar to close (20-30 lbs. pressure). The cover fabric may be tight. Over time under tension it will conform to its hardware and loosen slightly. If bar is too hard to push down, adjust tensioners equally as needed to close.

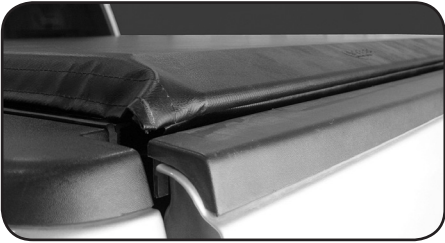

B. Close tailgate slowly—top of tailgate should fit snug under cover bar. If it is too tight—raise rails by loosening rear clamps, adjust rail up and tighten clamps. If too loose, adjust rails lower.

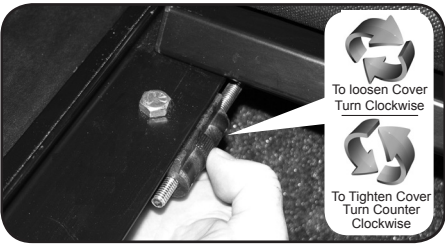

C. Check cover tension by releasing autolatch and open and close rear bar several times. It should snap down when closing. Cover fabric should sound drum-like when tapped on. If adjustment is needed, roll cover open and **to loosen turn EZ-Dial Clockwise. To tighten turn EZ-Dial Counter Clockwise. Always turn Dials in Equal amounts.** *See photo at left.*

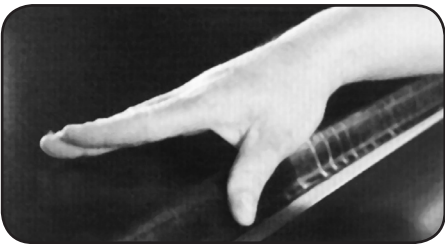

D. When done, always seal both sides of cover with hook and loop system. **For detailed operating instructions see Page 7.**

TIP: Reasons to keep cover drum tight:

- 1) Lasts longer
- 2) Less noise
- 3) Looks nicer

OPERATING INSTRUCTIONS

Note: view opening and closing demonstration video on www.accesscover.com

TO CLOSE



Release retainer straps at front and using both hands roll cover out to rear of box.



Position roll-up bar against strikes. Push down on bar until autolatch locks in place.



Now along side of box, seal cover edges with hook and loop sealing system the full length of cover on both sides. Pull with one hand - seal with other hand.

TO OPEN



Open tailgate on driver side, pull autolatch and lift up on rear roll bar.



Using both hands, roll cover toward front of box (not against the cab).



Securely fasten retainer straps to store the cover.

OPTIONAL USE



Manual Slide Lock (use is optional) is located under cover bar on passenger side - push slide lock to engage, pull to disengage.

PARTS DIAGRAM

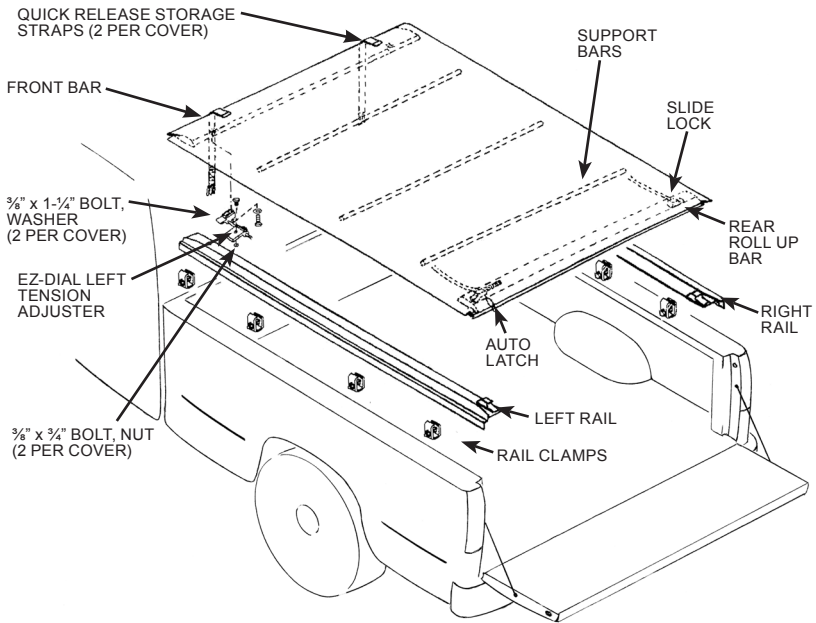

TROUBLESHOOTING

PROBLEM	SOLUTION
Cover too loose	Turn both tension adjusters counter clockwise to move front bar forward (Refer to #4C, see arrows next to adjuster)
Cover too tight	Turn both tension adjusters clockwise to move front bar forward (Refer to #4C, see arrows next to adjuster)
Gap between roll-up bar and tailgate	Rails set too high (Refer to #4B)
Cover is too wide	Check rails. Rails in - too wide - push all clamps to top of rail
Cover is too narrow	Rails out - too narrow - pull all clamps down on rail (Refer to #1D)
Lopsided cover too much on one side	Check front bar. It must be centered side to side (Refer to #3D)
Top of tailgate hits rear bar when attempting to close	Raise side rails at rear of box until tailgate closes without pushing rear bar up (Refer to #4B)
Auto latch doesn't engage	Check side rails for height and level. Inspect latch for jammed or broken parts. (Refer to #1D)
Manual slide lock (passenger side) too loose or too tight	Use 1/8" allen wrench and adjust set screw tighter or looser as desired. Lock performs best with some friction.

TIPS FOR A LONGER LASTING COVER

- Keep cover closed when not in use and always seal cover edges with hook and loop sealing system the full length of cover on both sides.
- Keep the cover tight, cover vinyl should sound drum-like when tapped on.
- Make sure cover is properly latched and sealed. Lock while traveling and before entering automatic drive-through car washes.
- Avoid storing cover in its rolled-up position for long periods of time.
- When cleaning, for best results use mild liquid soap and water. Never clean with petroleum or citrus based products.
- Periodically treat cover with our Cover Care cleaner & UV protectant instead of petroleum based products that may dry out and damage the vinyl.
- Avoid allowing cargo to rub against cover while transporting, whether in open or closed position.

INSPECTION AND MAINTENANCE

- Inspection and much of the maintenance can be done by the operator. It may be necessary to review the installation and operating instructions.
- Periodically inspect the cover assembly and the condition of all parts. Check for loose bolts and parts and tighten if needed. Test the operation to ensure that the parts are functioning properly and that the cover is in top operational condition.
- If latch has been damaged replace with new one. NOTE: Inspection and/or maintenance should also be performed anytime a malfunction is observed or suspected. If you need assistance inspecting and/or servicing your cover, or if you want to order a replacement part, call the customer service number on the back page. Always use original equipment replacement parts for your cover.

SAFETY INFORMATION

- Do not cover cargo that is higher than the cover.
- Do not place object(s) on or against the cover or its framework at any time
- Always secure cargo so it cannot shift and damage the cover or its parts.
- Do not use the covers framework to tie down cargo.
- Never stand, sit or ride on the cover or allow others to do so.
- Do not leave valuables in an unattended vehicle as cover does not prevent theft of contents in truck box.
- The cover does not eliminate moisture and dust from entering the truck box. Special wrappings or packaging of the contents may be necessary.
- Due to poor ventilation, if you allow a pet/animal in the box, leave cover open. Do not allow people or animals to occupy box with the cover closed.
- When towing vehicle backwards, cover must be rolled fully open and secured with safety straps or fully closed and secured with manual slide lock.
- ALWAYS finish securing the cover. Use caution when operating cover in windy conditions.
- Periodically check and/or retighten clamp bolts as needed.
- Periodically check and/or retighten front bar tensioning bolts as needed.
- Periodically check and/or adjust Autolatch strap to ensure latches fully engage side rails.



Customer Satisfaction Guarantee

- Your satisfaction is our goal!
- Agri-Cover delivers dependable, high quality products
- Reliable on time shipping
- Complete Order Guarantee, no back orders
- Knowledgeable & courteous customer service
- Call Agri-Cover with any questions 1-800-233-4655

Tested. Trusted. Guaranteed.

MANUFACTURER'S PREMIUM COVER™ LIMITED WARRANTY

Agri-Cover, Inc. extends the following five (5) year limited warranty to the original retail purchaser of any ROLL-UP COVER:

Agri-Cover, Inc. warrants to the original purchaser, for a period of five (5) years from the date of manufacture unless accompanied by proof of purchase of the cover, that its ROLL-UP COVER to be free from defects in material and workmanship, under normal use, as long as the original purchaser owns the truck on which the cover was originally installed and as long as the cover remains properly installed on said truck.

Agri-Cover, Inc.'s sole obligation under this limited warranty is limited to the repair or replacement, at its option, of defective parts only. No labor or service allowance is given or implied. **IN NO EVENT SHALL AGRI-COVER, INC. BE LIABLE FOR INCIDENTAL, CONSEQUENTIAL, OR SPECIAL DAMAGES.** AGRI-COVER, INC. EXPRESSLY DISCLAIMS ANY AND ALL IMPLIED WARRANTIES OF MERCHANTABILITY, AND THERE ARE NO WARRANTIES WHICH EXTEND BEYOND THE LIMITED WARRANTY DESCRIPTION CONTAINED HEREIN.

For warranty performance, call our Customer Service Department at 701-251-1427 to determine if only a replacement part is needed or if the cover needs to be returned for inspection and repair. **Warranty registration must be on file and/or proof of original purchase (detailed and dated receipt) required for warranty to be effective. Goods to be returned must have a pre-authorized RA # (Returned Authorization Number) - obtained by calling the number above.** Mark the number on the package and ship it freight prepaid to address below. Agri-Cover, Inc. will pay freight to return goods to sender.

This limited warranty does not cover any damage due to accident, abuse, misuse, alteration, neglect, improper installation, or ordinary wear and tear.

This limited warranty gives you specific legal rights and you may have other rights, which vary, from state to state.



Agri-Cover, Inc.
Customer Service Dept
3000 Hwy 281 SE
PO Box 508
Jamestown, ND 58402
Phone: 701-251-1427

ACCESS - A Division of Agri-Cover, Inc.

For ACI patent information, please visit: <http://www.agricover.com/patents/>

**PHONE 701-251-1427 7:30 am - 5:30 pm Central Standard Time
Monday thru Friday except Holidays**

Product must be registered to validate the warranty.
Go online to www.agricover.com/productregistration
to complete a registration form electronically.

WARRANTY REGISTRATION

1. Serial #: _____ Truck Model: _____
(Serial # found on sticker under bar at tailgate. If calling in please have serial number available.)
2. Name of roll-up cover purchased: _____
3. Price Paid: _____ Date of Purchase: _____
4. Dealers Name: _____
Dealers Location: _____
Dealers Phone: _____
5. Who installed the cover? Dealer Self
Other (specify) _____
6. How Would you Grade
- | | Excellent | Good | Average | Below Average | Poor |
|--|--------------------------|--------------------------|--------------------------|--------------------------|--------------------------|
| A. The Installation | <input type="checkbox"/> | <input type="checkbox"/> | <input type="checkbox"/> | <input type="checkbox"/> | <input type="checkbox"/> |
| B. Dealer Service | <input type="checkbox"/> | <input type="checkbox"/> | <input type="checkbox"/> | <input type="checkbox"/> | <input type="checkbox"/> |
| C. Value for the Money | <input type="checkbox"/> | <input type="checkbox"/> | <input type="checkbox"/> | <input type="checkbox"/> | <input type="checkbox"/> |
| D. Overall Satisfaction
with dealer | <input type="checkbox"/> | <input type="checkbox"/> | <input type="checkbox"/> | <input type="checkbox"/> | <input type="checkbox"/> |
7. How did you first hear about this cover?
 Friend Dealer Advertisement (specify) _____
 Seen on a Truck At a Show Other (specify) _____
8. Would you recommend this cover to a friend? Yes No
9. Comments/Suggestions: _____

10. Your Name: _____
Address: _____
City, State, Zip: _____
Phone: _____
E-mail: _____
11. Age Range
 21-34 35-44 45-54 55-64 65-Over
12. Income Range
 \$20K-\$40K \$41K-\$60K \$61K-\$80K \$81K-\$100K \$100K +

Thank you for helping us serve you better.

Warranty form above may also be mailed to:

Agri-Cover, Inc.
P.O. Box 508
Jamestown, ND 58402

Smart Accessory Products from



Original Roll-Up Cover

Truck Bed Mat

LED Truck

EZ-Retriever™ II



TrailSeal™

**Tailgate
Protector**

**G2 Bed
Pockets**



866-797-3513 • accesscover.com



3 Distinct Models To Choose From



HD UTILITY PLOW

ALL TERRAIN PLOW



180 UTILITY PLOW

888-837-0852

Plow Your Own Lot!

- Pays for itself in one season!
- Simple bolt on mount, installs in minutes
- No electric or hydraulic components to freeze or malfunction
- The turf-friendly rubber cutting edge won't scratch your landscaping or tear up the grass!
- Easy storage between snowfalls or during off season

TURF FRIENDLY



Built in trip edge won't scratch concrete, brick or black top, tear up grass surfaces or remove gravel.

NO EXTRA LIGHTS



The practical design does not block headlights in plow or transport position.

EASY TO LIFT



Our plows are easily lifted by one person. Lower the blade, plow until finished, then lift the blade back to transport position.

RUST RESISTANT BLADE



Heavy duty, corrosion resistant, anodized aluminum blade repels rust, so it never needs painting.

**See it to
believe it!**



**Install
Video
Available
Online**

mysnowsport.com

