

Supplemental Installation Instructions

2007 Ford Explorer Sport Trac

RE: Rail Clamping Procedure Cover #132

Tools Needed:

- a) #10mm box wrench
- b) T30 torx wrench
- c) Inch pound torque wrench
- d) Protective eyewear

1. This kit comes with 4 long clamps and 2 short clamps that attach to existing threaded holes at front, middle, and rear of box. Place cover side rail above indentation along inside of box wall.

(SEE FIGURE 1).

2. At front of rail, mount 1st long clamp using a new bolt, lock washer, and flat washer. Turn bolt into existing threaded sleeve in box wall. Adjust clamp up as high as needed to level rail when tightening. After tightening - check rail for level. If rail tilts down - clamp will need to be loosened, moved up and retightened. If rail tilts up - clamp will need to be loosened, moved down and retightened. Do this until rail is level. Torque to 75 inch pounds.

(SEE FIGURE & FIGURE 2).

3. Near center of box remove existing T-30 bolt (SEE FIGURE 3) and install a short clamp. Re-use existing bolt, add lock washer and flat washer from kit and torque bolt to 75 inch pounds. Adjust clamp up or down as needed to hold rail level.

4. At rear of box, install another long clamp (SEE FIGURE 4) into existing threaded sleeve. Use a new bolt, lock washer and flat washer from kit. Tighten to 75 inch pounds. Again, check rail for level and adjust clamps up or down as needed. Repeat procedure for both side rails.

NOTE: When rails are level check all clamp bolts to ensure they are torqued to 75 inch pounds.

Finish the remaining cover install beginning with Element Seal and pre-rolled cover in general owners manual.

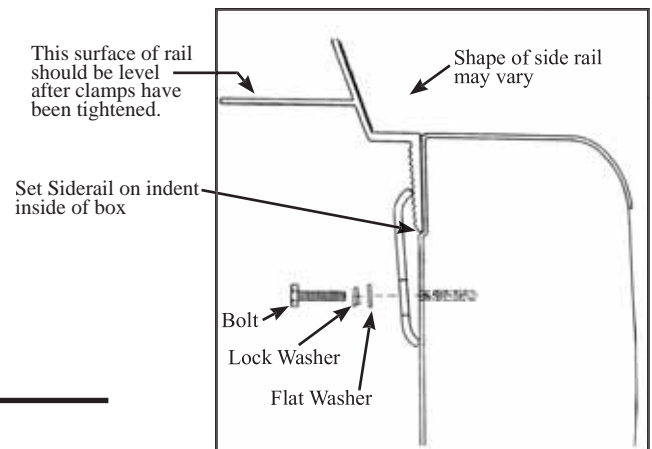

FIGURE 1

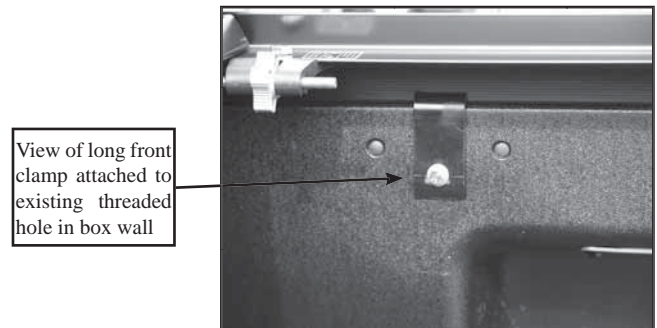

FIGURE 2

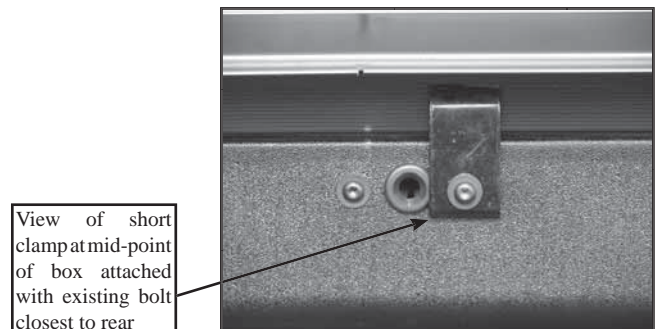

FIGURE 3

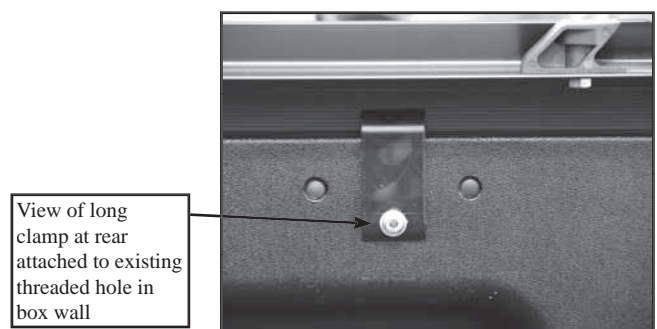

FIGURE 4