



INSTALLATION INSTRUCTIONS

Thank you for purchasing ROCTECTION™ Hitch Mounted Mud Flaps. ACI™ manufactured these mud flaps with pride using superior quality materials and workmanship. With proper care, your mud flaps will provide years of service and enjoyment.

NOTICE TO INSTALLER: It is recommended instructions are read before installation, even if familiar with mud flaps. Improvements may be made without prior notice. Always handle components with care. If you have any problems or questions, have serial number ready and call customer service. When done, this owner's manual must be given to the consumer.

NOTICE TO CONSUMER: Before using mud flaps, read maintenance and safety sections and save owner's manual for future reference.

FOR YOUR RECORDS

DATE PURCHASED: _____

WHERE PURCHASED: _____

SERIAL NUMBER: _____

(Located on decal on back of frame)



Questions? (888) 568-3709
agricover.com

PREPARATION

TOOLS NEEDED

9/16" Wrench
Foot pound torque wrench with 9/16" socket
Utility knife
Straight edge
Protective eyewear
Protective gloves
Drill with 13/32" drill bit

NOTE: Some modification may be needed for your truck model.

1: ASSEMBLE FRAME

Attach square channel to frame by inserting (2) 1-1/4" carriage bolts, secure with flange nylock nuts (nut channel facing away from frame). Tighten bolts, but do not over tighten. Repeat on opposite side.

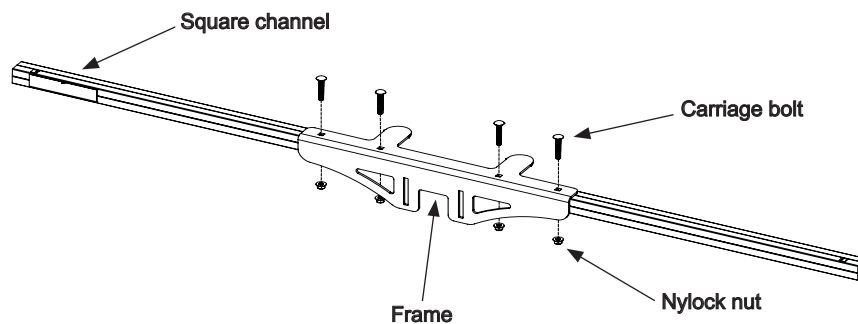

2: ASSEMBLING CLAMP

Insert (2) long carriage bolts through upper and lower clamps and hand tighten nylock nuts.

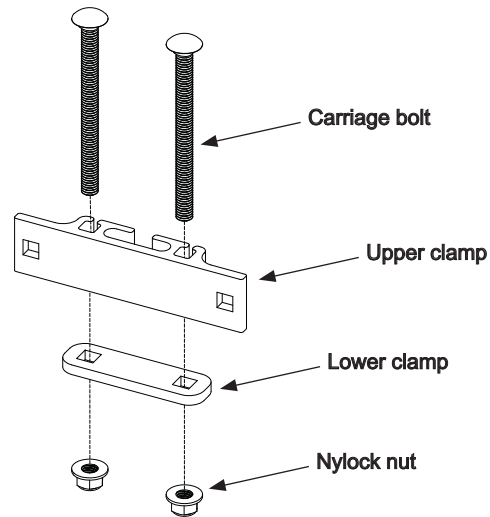

3: ASSEMBLING CLAMP TO FRAME

Orientate flat surface of clamp assembly on back of frame so nuts face down. Attach clamp to frame with (2) 1-1/4" carriage bolts and flange nylock nuts, leave all bolts loose for now.

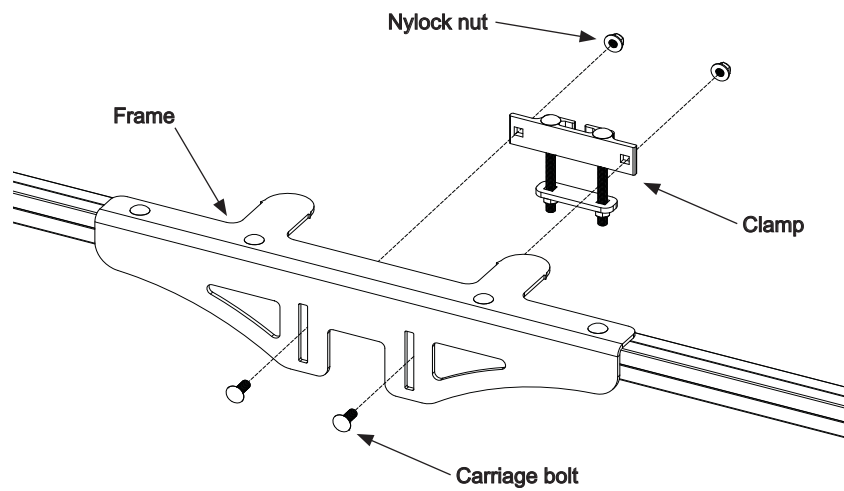

4: INSTALLING VINYL CAPS

Slide vinyl caps onto support flanges of frame.

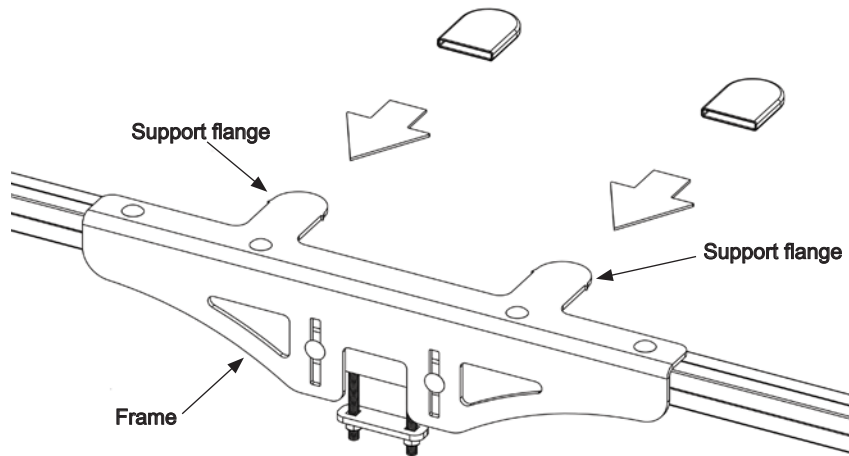

5: ASSEMBLING CLAMP TO BALL MOUNT

Slide ball mount through frame and clamps. Lift assembly up and insert ball mount into receiver. Secure with pin and clip.

NOTE: If ball mount holes do not align to allow pin to be inserted or if mud flap frame cannot be positioned to hang straight and plumb, a longer ball mount may be needed before proceeding.

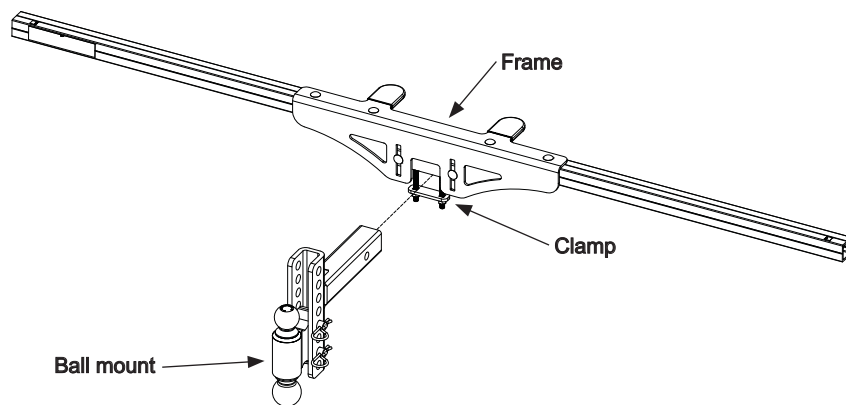

6: PLACING ROTECTION ON BUMPER

Position support flanges on bumper step. A gap should be left between the frame and the bumper. Loosely tighten 1-1/4" carriage bolts on clamp assembly.

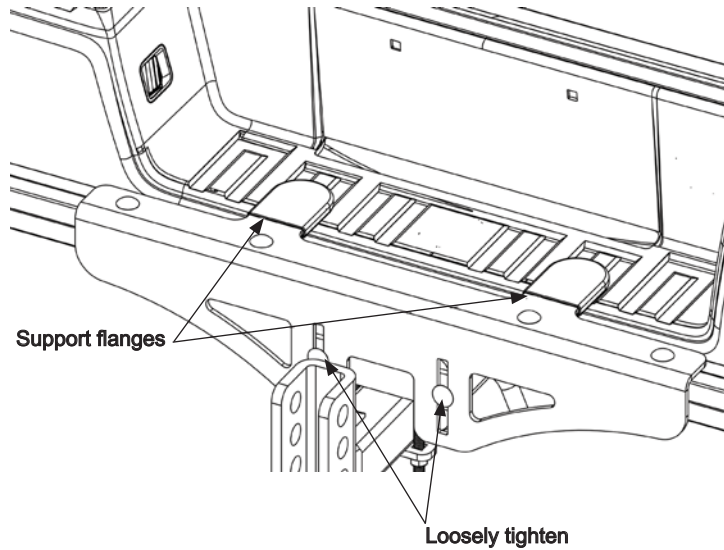

Next ensure frame is level with bumper, push down on frame firmly at bumper step. Make sure vertical face of frame is plumb and tighten bolts equally. Torque all (4) clamp bolts to 32 ft-lbs.

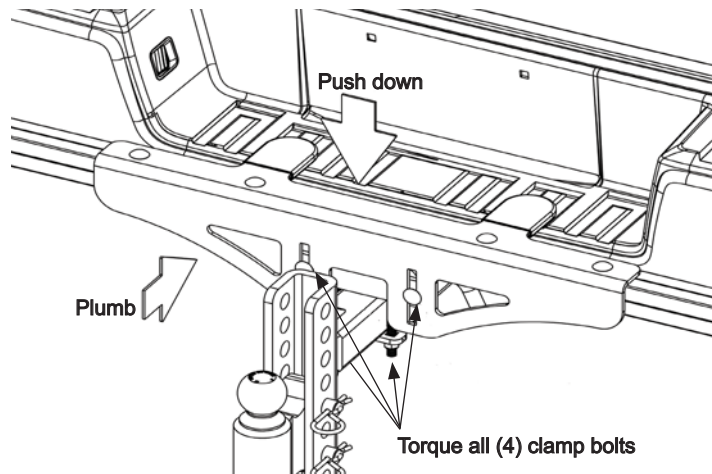

7: ATTACHING FLAPS TO FRAME

IMPORTANT: Ensure exhaust fumes are NOT directed onto any plastic or flaps, including on the vehicle. Additional precautionary measures may need to be taken to divert exhaust.

Optional heat shield available to protect flap from hot exhaust (see page 10 for details). For exhaust pointed out the rear of the truck, cut 1" hole or larger around the exhaust. Keep hole locations away from edges of flap to prevent loss of strength.

Always check ground clearance of flaps. Suggested clearance without a load is 5-7". Suggested clearance with a load is 3" minimum to prevent mud flaps from dragging.

Orientate each flap strip with textured side facing away from tires. Drill mounting holes 4" from edge at preferred height. Insert 1-1/4" hex bolts, lock washers, and fender washers into flap, secure with weld nut. Keep loose for now. Repeat on opposite side.

NOTE: If trimming is necessary, remove mud flap assembly and use straight edge to mark a cut line at bottom of each flap. Trim / cut along line.

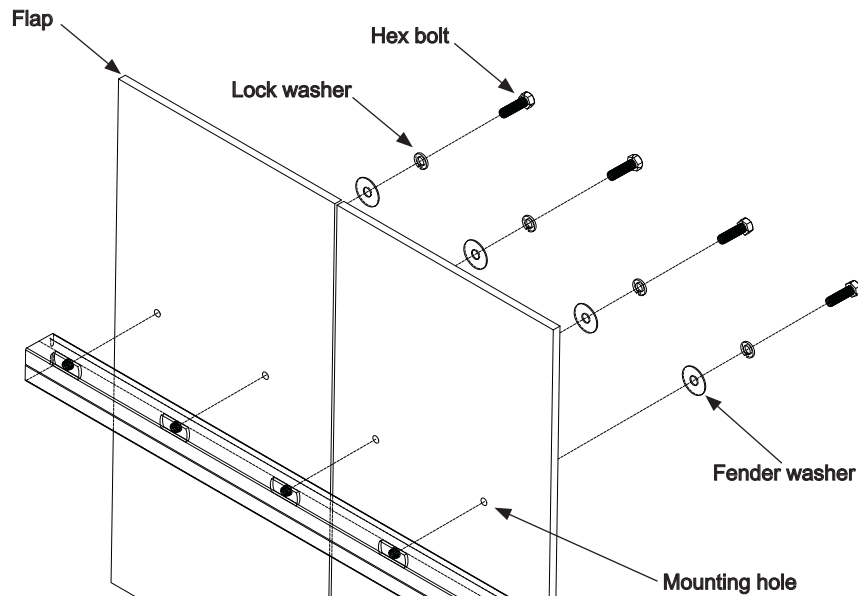

8: INSTALL FLAPS ON FRAME

Attach both flaps by sliding the weld nut on back of flap into the frame's nut channel. Repeat on opposite side.

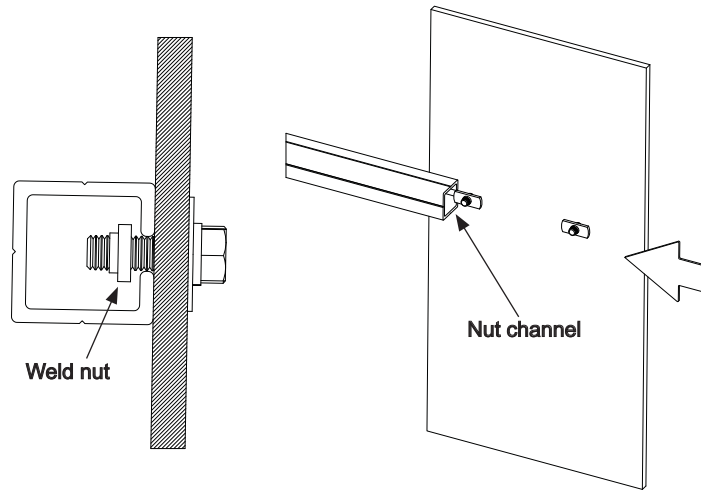

9: INSERT TUBE PLUG

Push tube plugs firmly into each end of frame.

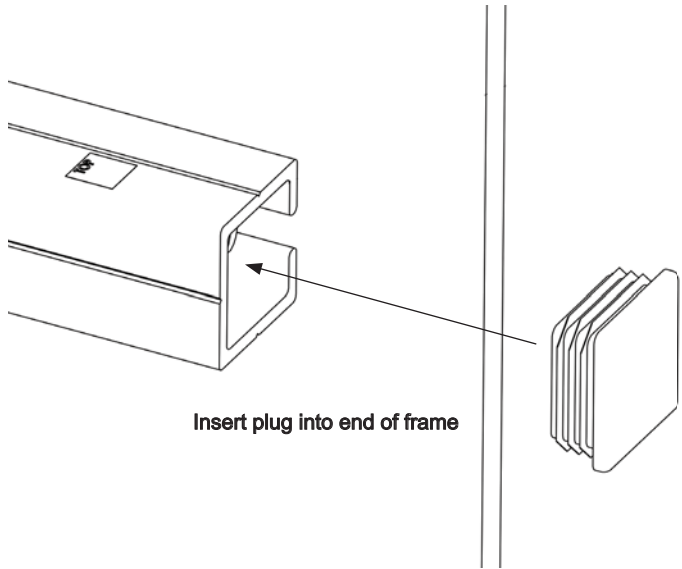

10: SECURE FLAPS

Slide outside flap back to edge of frame and align with the outside of your tire. Slide inside flap almost against the outside flap. Keep 1/16" to 1/8" between flaps. Tighten weld nuts until lock washers are fully compressed.

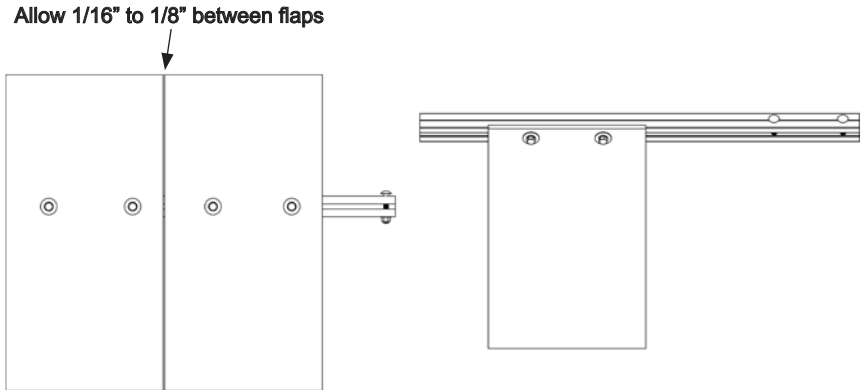

SAFETY AND MAINTENANCE

- Always route safety chains under mud flap frame, not through holes.
- Always remove mud flaps before entering automatic car wash systems.
- DO NOT use mud flap frame as a step.
- DO NOT hook up anything to mud flap frame.
- **Periodically check all bolts and nuts, retighten if needed.**
- California Proposition 65: This product contains or emits chemicals known to the state of California to cause cancer, birth defects, and other reproductive harm.

ACCESSORIES

Heat Shield

Protects the flap from hot exhaust.
Stainless steel plate and hardware
included.

PN 80807



Extended Shaft 2" Ball Mounts

Black powder coated finish with up to
7,500 lbs. capacity. Extended shaft
made to work with hitch mounted mud
flaps.

Two Options:

2" Drop PN 80812

4" Drop PN 80826



MANUFACTURER'S LIMITED WARRANTY

Agri-Cover, Inc. extends the following one (1) year Limited Warranty for the ROCTECTION™ Hitch Mounted Mud Flaps:

Agri-Cover, Inc. warrants ROCTECTION™ Hitch Mounted Mud Flaps to be free from defects in workmanship, under normal use, as long as the mud flaps remain properly installed for one (1) year from date of manufacture. This Limited Warranty does not cover any damage due to accident, abuse, misuse, alteration, neglect, improper installation, or ordinary wear and tear.

Agri-Cover, Inc.'s sole obligation under this Limited Warranty is limited to the repair or replacement, at its option, of defective parts only. No labor or service allowance is given or implied. IN NO EVENT SHALL AGRI-COVER, INC. BE LIABLE FOR INCIDENTAL, CONSEQUENTIAL, OR SPECIAL DAMAGES. AGRI-COVER, INC. EXPRESSLY DISCLAIMS ANY AND ALL IMPLIED WARRANTIES OF MERCHANTABILITY, AND THERE ARE NO WARRANTIES WHICH EXTEND BEYOND THE LIMITED WARRANTY DESCRIPTION CONTAINED HEREIN.

For warranty, have your serial number ready and call our Customer Service Department at (888) 568-3709 to determine if only a replacement part is needed or if the mud flaps need to be returned for inspection and repair. Goods to be returned must have a pre-authorized RA # (Returned Authorization Number) - obtained by calling the number above. Mark the number on the package and ship freight prepaid to address below. Agri-Cover, Inc. will pay freight to return goods to sender.

This Limited Warranty gives you specific legal rights and you may have other rights, which vary, from state to state.

For replacement parts shop at roctection.com or call Customer Service at (888) 568-3709.



Agri-Cover, Inc.
Customer Service Dept
PO Box 508 | 3000 Hwy 281 SE
Jamestown, ND 58402
Phone: (888) 568-3709

PHONE (888) 568-3709 8:00 am - 5:00 pm CST Monday through Friday except Holidays