

CHASSIS MOUNTED BOX DETAIL SHEET

Accurate physical, tape measurements are essential for proper fitting tarp. Complete form along with appropriate section in Systems Guide.

CONTACT INFORMATION

Name _____ Date _____
 Address _____
 City _____ State _____ Zip _____
 Email/Phone _____

BOX MEASUREMENTS Exact Measurements Required

Top Outside Box Length (A) _____
 Top Outside Box Width (B) Front _____ Rear _____
 Box Height From Ground (C) _____
 Top Rail Width (D) _____
 Box Extension Kit (10" tall) _____ Box Extension Divider(s) Qty. _____

ROLL TARP SYSTEM

SRT-2 _____ EZ-LOC HD _____ EZ-LOC _____ Side Locking _____

KIT MATERIAL

Galvanized Steel _____ Stainless Steel _____

OPERATION

Manual Return _____ Electric _____

ELECTRIC (see electric conversions section for more information)

Cab Operated _____ Switch Control _____ Control Box and Remote _____

CONVERSION

ROLTEC Rear Option _____

SRT-2 _____ ECONOMICAL _____

HOIST

w/o Hoist _____ w/ Hoist Extra Wire _____

END CAPS

| | | | |
|----------|---------------|-----------|------------------|
| QUANTITY | None | 1 | Recommended (2) |
| MATERIAL | Galvanized | Aluminum | Stainless Steel |
| RISE | 7" | 12" | Flat |
| DEPTH | 14" | 10" | |
| FRONT | Side Mount | Top Mount | |
| REAR | Side Mount | Top Mount | |
| BRACKETS | Side | Top Z | Top Bolt Through |
| | Quick Release | | |

FILLERS

| | | | |
|--------------------|-------------------------------|------------------------------|--------|
| FRONT | Metal | 18 oz. | 22 oz. |
| REAR | Metal | 18 oz. | 22 oz. |
| DEPTH | Front (I ¹) _____ | Rear (I ²) _____ | |
| MOUNT (metal only) | Front Side Top | Rear Side Top | |
| DROP (fabric only) | Front (M) _____ | Rear (K) _____ | |

TARP

18 oz. Vinyl _____ 22 oz. Vinyl _____ 9 oz. Mesh _____ 21 oz. Mesh _____

Tarp Color(s) _____

RIDGE SUPPORT

None _____ Strap Qty. _____ Rope Qty. _____

BOWS (included up to 28')

None _____ Recommended Qty. _____ Custom Qty. _____
 Side Mount _____ Top Mount _____

BOX MEASUREMENTS

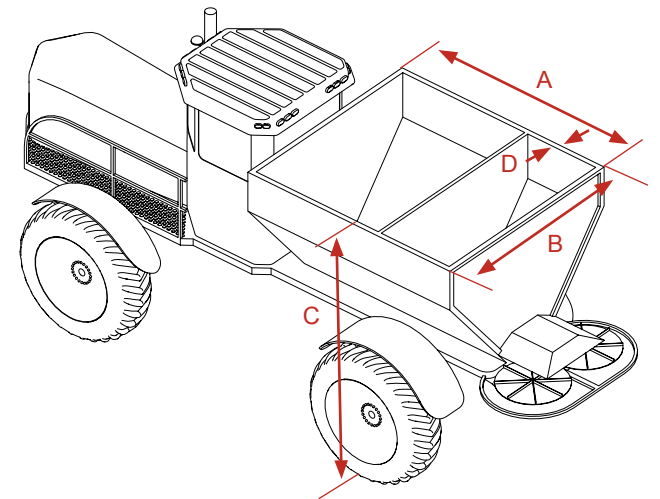
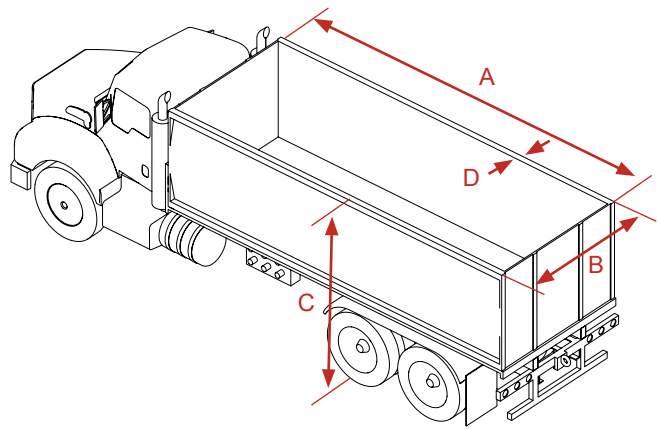

FILLERS

Metal

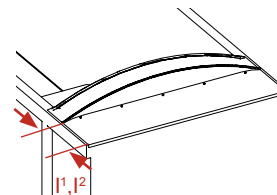

Fabric (18 oz. or 22 oz.)

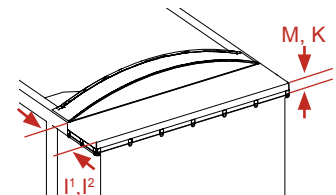

| ADDITIONAL OPTIONS AND ACCESSORIES | QTY. |
|------------------------------------|------|
| | |
| | |
| | |
| | |
| | |
| | |
| | |
| | |
| | |
| | |



3000 Hwy 281 SE
 Jamestown, ND 58401
 T (800) 233-4655
 F (800) 592-4460
 orderdesk@agricover.com