



INSTALLATION INSTRUCTIONS

Thank you for purchasing AGRI-COVER® Side Locking Tarp. Agri-Cover, Inc. proudly manufactured this tarp using superior quality materials and workmanship. With proper care, your tarp system will provide years of service.

NOTICE TO INSTALLER: Even if familiar with product, read instructions prior to installation as improvements may be made without notice. Always handle components with care. If you have questions or problems, have serial number ready and call customer service. When done, these instructions must be given to the consumer.

NOTICE TO CONSUMER: Before using this product, read operating, maintenance and safety sections. Save these instructions for future reference.

FOR YOUR RECORDS

DATE PURCHASED: _____

WHERE PURCHASED: _____

TARP SERIAL NUMBER: _____

(Located at rear of tarp on stationary tube side)



Questions? (800) 233-4655
agricover.com

PREPARATION

- Prior to tarp system assembly, park truck or trailer on level ground.
- Box must be square and straight, center must not be pulled together or spread apart.
- Before beginning, measure outer length and width of your box. Also measure length of tarp and width of the end caps to ensure you received the correct size.
- Remove or grind smooth any sharp edges or points contacting tarp and/or cables.
- Remove or reposition any interferences with tarp. If modifications to box are needed, consult box manufacturer.
- It may be necessary to use washers and nuts or other types of fasteners (not furnished) to ensure a solid anchor.
- Ensure box extension is secure by bolting in place on top of your box.

TOOLS NEEDED

- Welder and helmet
- 9/16" and 3/4" Wrenches
- Phillips screwdriver
- 3/16" and 7/32" Allen wrenches
- Step ladders or scaffolding
- Drill with 5/16" and 7/32" bits
- Tape measure
- Impact wrench with 9/16" socket
- Protective eyewear
- Marking pencil
- Hammer
- Angle grinder
- Cutting tool(s)
- Rubber mallet

OPTIONAL TOOLS NEEDED

- C-clamps
- Locking pliers

NOTE: Hardware appearance and components may vary.

▲ CAUTION: Before drilling, ensure there are no hidden wires or gussets in line with holes to be drilled.

STAINLESS STEEL HARDWARE ONLY

▲ CAUTION: To avoid galling of stainless steel hardware, use anti-galling spray, grease or lubricant on threads and avoid high speed when fastening. Do not use impact tools for stainless steel hardware.

A. Turn 3/8" x 1" non-stainless steel self-threading bolt in 5/16" hole to cut threads, then turn back out.

B. Turn 3/8" x 1" stainless steel bolt in for attachment. When possible, use stainless steel nuts and washers with these bolts.

SAFETY INFORMATION

▲ DANGER: Mounting replacement tarp to a structurally weak or damaged roll tube can result in serious injury or death.

Before installing replacement tarp, inspect mounting surface of roll tube. Be aware several mounting holes in close proximity may compromise roll tube strength and integrity. Ensure mounting location on roll tube provides adequate tarp support.

- Disconnect power before servicing tarp system or electrical components.
- Always use caution when operating tarp system.
- Ensure people and objects are clear of tarp system before and during operation.
- Instruct everyone who will operate tarp system on the proper procedures.
- Never allow children to operate or play with tarp system.
- Do not operate tarp system with box hoisted in elevated position.
- Ensure tarp system is fully open or fully closed before operating vehicle at highway speeds.
- Only operate tarp system when tarp is completely visible.
- Always refer to OEM instructions before installing electrical components.
- Do not use arm as a step.
- Remove snow or debris from top of tarp system before operating.
- End caps must be free from commodity. Commodity should not be piled higher than end caps.
- Do not directly spray motor or connections with a pressure washer.
- Ensure tarp system is fully open before unloading or loading.

NOTE: Safety and operating procedure decals provided with this kit should be kept clean at all times and replaced if worn, damaged, painted over or unreadable.

1: INSTALLING WEATHER SEAL TO END CAPS

NOTE: For best adhesion, ensure air and surface temperatures are above 60° F.

A. Test fit end cap, it should measure at least 1/2" or at most 1-1/2" narrower than top of box on both sides.

NOTE: Modify end cap if needed by notching overhang, removing protruding objects from box or trimming end cap width.

B. At each end, clean underside of end cap.

C. Align weather seal as shown. Test fit on end cap, adjust for optimum seal and trim if needed.

D. Peel protective backing then adhere seals to each side of end cap.

IMPORTANT: Sharp edges cause tarp damage not covered by warranty. Ensure end cap edges are installed tight to box. Always inspect areas where tarp closes around end caps and top corner of box and make required adjustments.

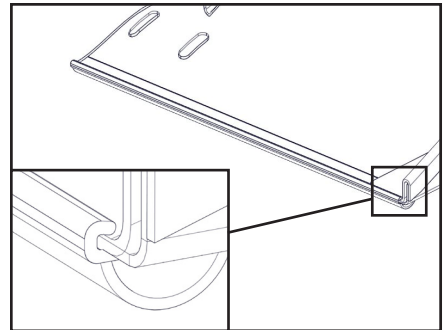
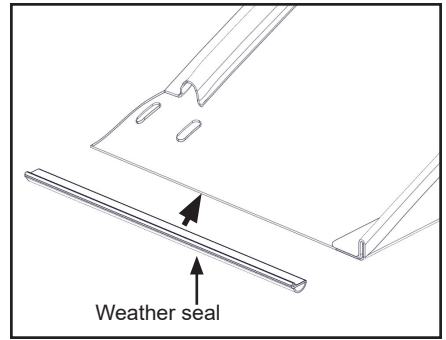
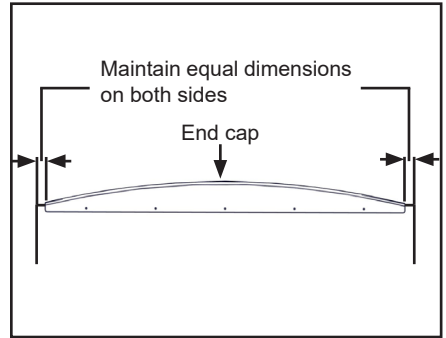

2: INSTALLING END CAPS

Perform one of the following to install end cap:

▲ CAUTION: Do not stand or walk on end cap.

NOTE: For stainless steel hardware, see page 2 for bolting procedures.

SIDE MOUNT

A. Center end cap on box. Press down and back against box to compress weather seal and drill 5/16" holes in box wall at each factory hole in end cap.

B. Fasten with 3/8" x 1" self-threading bolts.

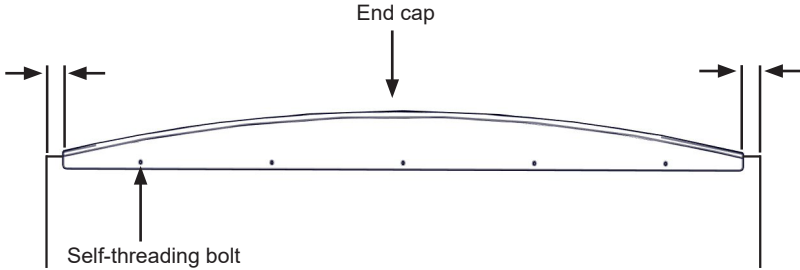

TOP MOUNT

A. Center and position end cap to overhang end of box by 1/4". Mark deepest location at each hole on top of box.

B. Remove end cap and drill 5/16" holes at marked locations. Turn 3/8" x 1" self-threading bolts halfway in. Slide end cap slots under bolt heads. Ensure 1/4" overhang, press down to compress weather seal and finish tightening bolts.

Tip: If box has uneven layer of metal at top where end cap mounts, apply adhesive seal tape and shim with washers (not included with kit) under end cap at each bolt.

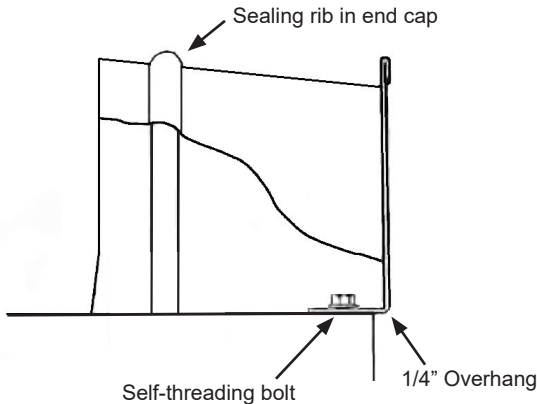

3: MOUNTING END CAP BRACKETS

Perform one of the following to mount end cap brackets or use included instructions if applicable:

NOTE: For stainless steel hardware, see page 2 for bolting procedures.

SIDE MOUNT

- A. Center end cap bracket underneath sealing rib of end cap and butt up against inside of box. Use bracket as template to mark center of (4) hole locations.
- B. Drill (2) 5/16" holes through box at marked locations and secure with 3/8" x 1" self-threading bolts.
- C. Drill (2) 3/8" holes through end cap at marked locations. Tilt inside edge of end cap up 1/4" and secure with 3/8" x 1" Allen button head bolts and nuts.
- D. Repeat Steps 3A-C to install end cap bracket on opposite side.
- E. Repeat Steps 1-3 for remaining end cap.

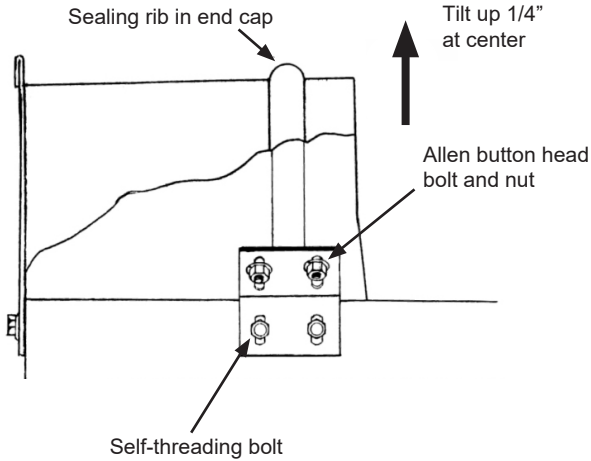

TOP BOLT THROUGH

- A. Tilt inside edge of end cap up 1/4" and drill 5/16" hole at etched mark on both sides of end cap.
- B. Use 3/8" x 1" self-threading bolt to cut threads. Secure with 3/8" x 1" Allen button head bolt.
- C. Repeat Steps 1-3 for remaining end cap

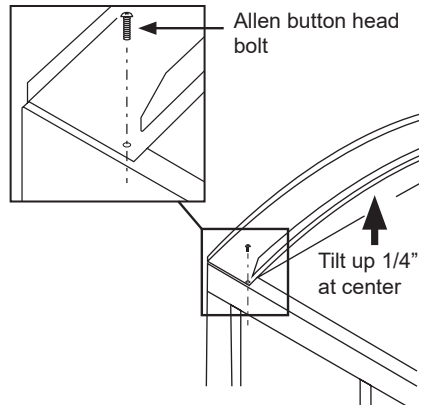

4: DETERMINING BOW PLACEMENT

NOTE: Supplied bows are not designed to hold box together. Leave all existing bows, braces and chains in place.

A. First and last bow should be placed 30" in from end cap face.

B. Divide space from first to last bow by number of bows left plus one to determine position of remaining bows.

IMPORTANT: All bows must be used.

* Example:

If - 2 bows are left,
divide by 3 for 3 equal spaces

If - 4 bows are left,
divide by 5 for 5 equal spaces

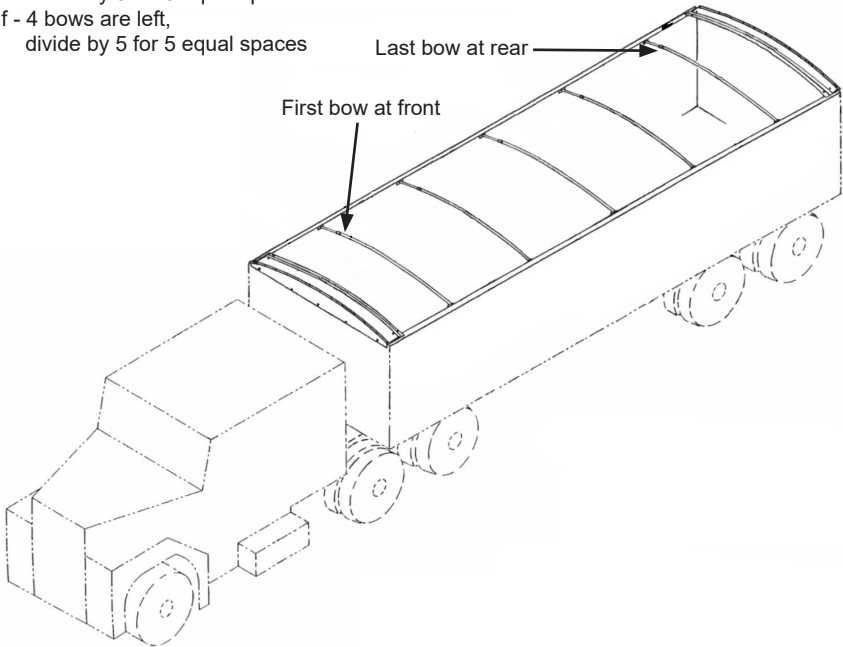

5: MOUNTING BOWS

Perform one of the following to mount bows:

NOTE: For stainless steel hardware, see page 2 for bolting procedures.

SIDE MOUNT

A. Attach bow pocket to inside of box, flush with top. Use pocket as template to drill (2) 5/16" holes and secure with 3/8" x 1" self-threading bolts.

B. Repeat for opposite side.

C. Slide bow extension into end of bow and place bow into bow pockets.

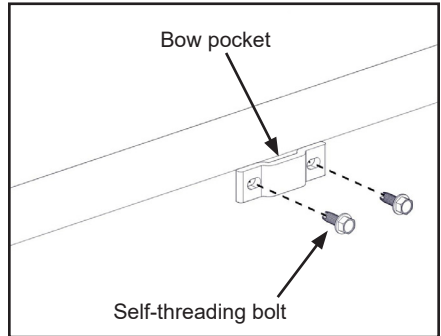

TOP MOUNT

A. Ensure 1/2" space from outside edge of box rail to bow. Drill 5/16" hole and use 3/8" x 1" self-threading bolt to cut threads. Secure with 3/8" x 1" Allen button head bolt.

B. Slide bow extension into end of bow.

C. Repeat Step 5A for opposite side.

NOTE: Deburr any sharp edges at bow ends.

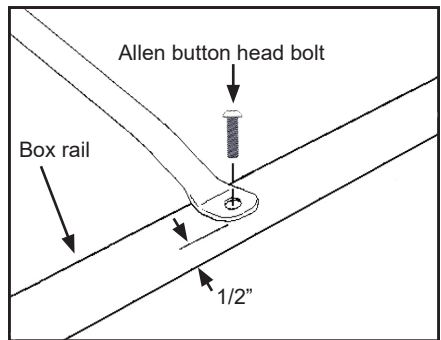

BOTH SIDE AND TOP MOUNT

D. Center first bow in an upright position and adjust to sit 1" higher than end cap.

Tip: Clamp locking pliers to hold in place.

E. Drill 5/16" hole 1" from end of bow through bow and into extension. Secure with 3/8" x 1" self-threading bolt.

IMPORTANT: Ensure bolt head does not rub on tarp.

F. Repeat Step 5 for remaining bow locations.

Tip: Set front and rear bows to correct height. Install ridge strap and draw tight until no slack. Adjust remaining bows to touch bottom of ridge strap, ensure strap remains level.

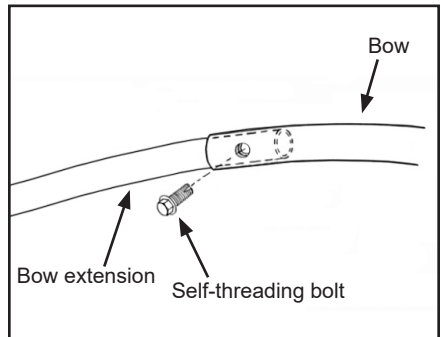

5: MOUNTING BOWS (Continued)

HD ALUMINUM

A. Set bow pocket on top of inside edge of box rail. Use pocket as template to drill (4) 5/16" holes and secure with 3/8" x 1" self-threading bolts.

NOTE: Shim (not included with kit) behind bow pockets if necessary.

B. Repeat for opposite side.

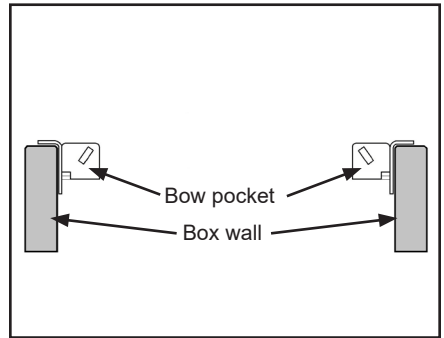

C. Place bow with factory drilled hole into bow pocket. Secure with carriage bolt and nylock flange nut, leaving finger tight.

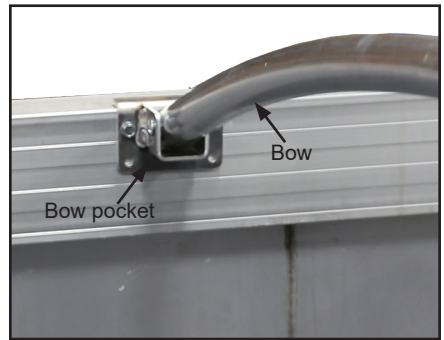

D. Place bow extension into opposite bow pocket. Secure with carriage bolt and nylock flange nut, leaving finger tight. Hold bow up to bow extension and make mark at bow extension collar on bow. Remove bow from bow pocket, then cut at mark.

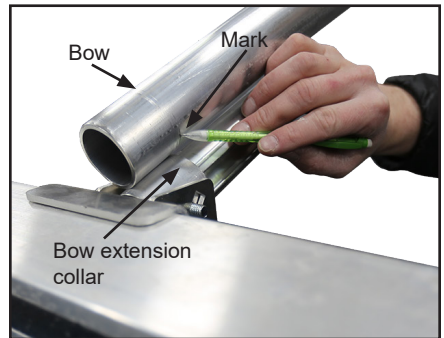

IMPORTANT: Make cut perpendicular to bow. Do not cut end of bow with factory drilled hole.

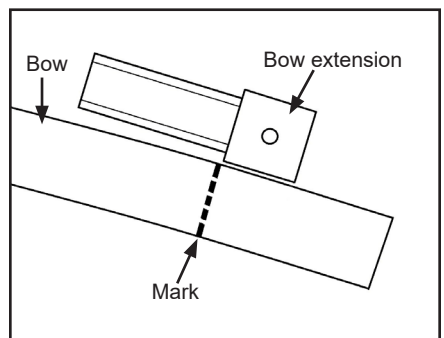

5: MOUNTING BOWS (Continued)

E. Slide bow extension into trimmed end of bow. Place bow into bow pockets and secure each end with 3/8" x 3" carriage bolt and nylock flange nut.

NOTE: Extension will sit loose within the bow.

F. Repeat Step 5 for remaining bow locations.

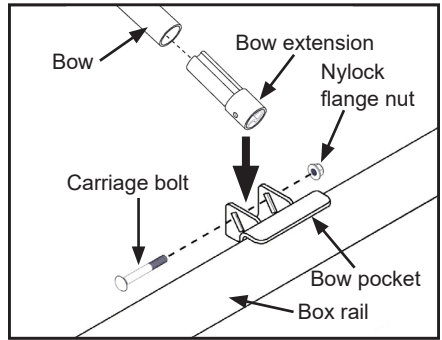

FLEXIBLE

A. Measure inside trailer box width and perform one of the following:

7" Rise - Cut bow 1-1/2" longer than inside measurement.

12" Rise - Cut bow 4" longer than inside measurement.

NOTE: Adjust bows as needed for desired height.

B. Clamp bow pocket flush with top of box, use pocket as a template to drill (4) 5/16" holes. Secure with 3/8" x 1" self-threading bolts.

C. Repeat for opposite side.

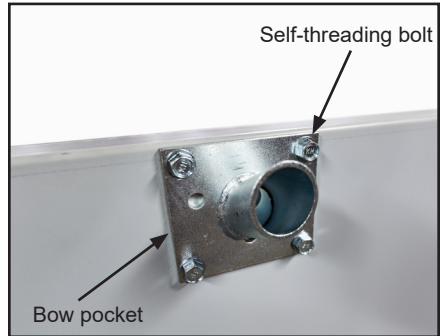
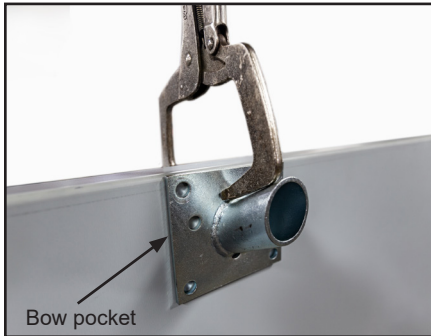

D. Insert flexible bow into bow pockets.

E. Repeat Step 5 for remaining bow locations.

IMPORTANT: Ensure bow is fully seated before continuing.

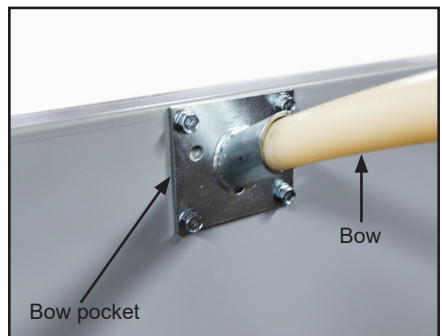

5: MOUNTING BOWS (Continued)

TIP: Loosening bow pocket hardware may ease bow insertion, then fully tighten hardware.

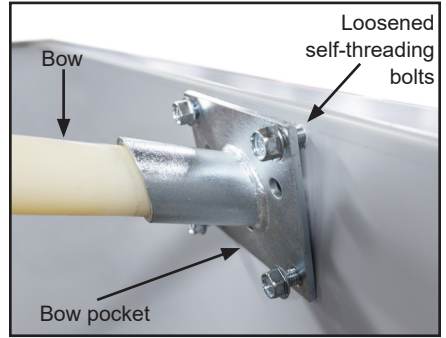

6: MOUNTING RIDGE SUPPORT

Perform one of the following to mount ridge support:

RIDGE STRAP

A. Attach hook end of strap to hole in center of front end cap. If installing (2) ridge straps, attach hooks to off centered holes.

B. Run strap over bows and attach ratchet end of strap to rear end cap. Thread strap through ratchet, then draw strap tight. **DO NOT OVER TIGHTEN**. Cut excess strap to 8" and fuse end with heat source.

Tip: Twisting ridge strap prior to attaching ratchet helps decrease commodity spatter. Number of twists depends on length of trailer, adjust accordingly. Ensure not to wind any twists in ratchet.

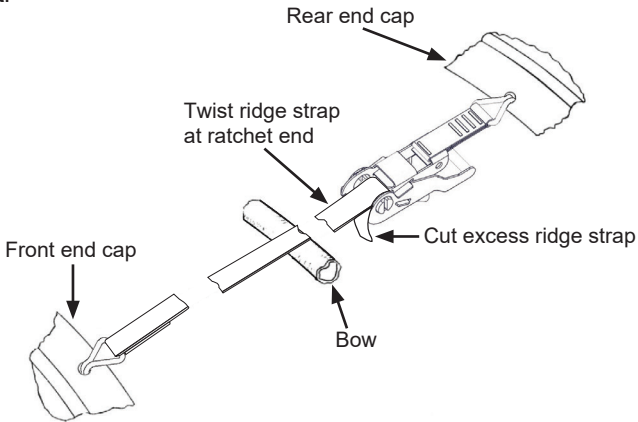

RIDGE ROPE

A. Attach hook end of rope to hole in center of front end cap. If installing (2) ridge ropes, attach hooks to off centered holes.

B. Run rope over bows and attach ratchet end of rope to rear end cap. Thread rope through ratchet as shown, pull on loose end of rope to remove slack. Ratchet rope tight, at least 4 wraps. **DO NOT OVER TIGHTEN**. Cut excess rope to 8" and knot end.

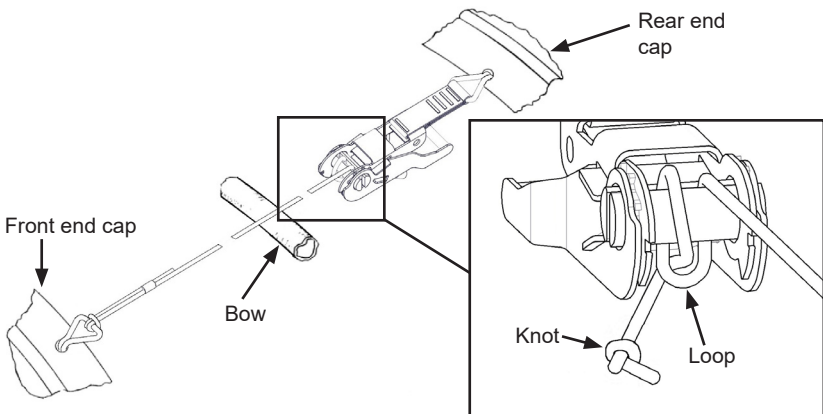

7: DETERMINING TARP STOP PLACEMENT

NOTE: Tarp stops secure stationary side of tarp to box.

- For normal roll applications, mount tarp stops on passenger side of box.
- For reverse roll applications, mount tarp stops on driver side of box.

A. Place front and rear tarp stops in line with sealing rib in end cap.

B. Divide space from front to rear tarp stop by number of tarp stops left plus one to determine position of remaining tarp stops.

*Example:

If - 2 tarp stops are left,
divide by 3 for 3 equal spaces

If - 4 tarp stops are left,
divide by 5 for 5 equal spaces

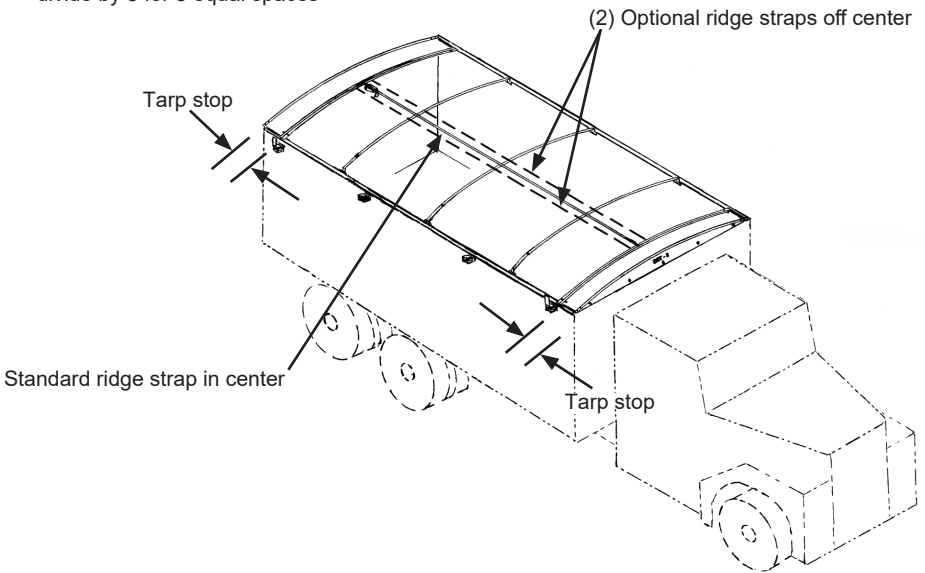

8: MOUNTING TARP STOPS

Perform one of the following to mount tarp stops:

NOTE: For stainless steel hardware, see page 2 for bolting procedures.

BOLT-ON TARP STOPS

A. Mark locations for bolt-on tarp stops.
Install is completed when installing tarp.

B. If using optional tarp stop spacer bracket, use bracket as template to drill (2) 5/16" holes and secure with 3/8" x 1" self-threading bolts, lock washers and nuts.

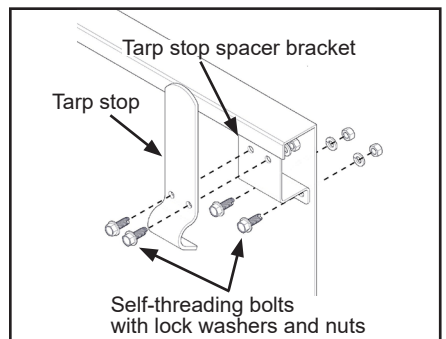

8: MOUNTING TARP STOPS (Continued)

QUICK RELEASE TARP STOP

A. If using optional tarp stop spacer bracket, use bracket as template to drill (4) 5/16" holes and secure with (2) 3/8" x 1" bolts, lock washers and nuts and (2) 3/8" x 1-1/4" Allen button head bolts, lock washers and nuts.

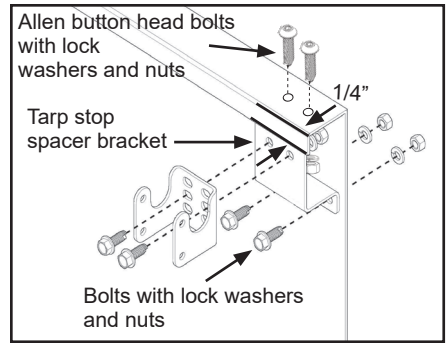

B. Place front and rear base brackets 1/4" down from top of box and drill (4) 5/16" holes and secure with 3/8" x 1" self-threading bolts.

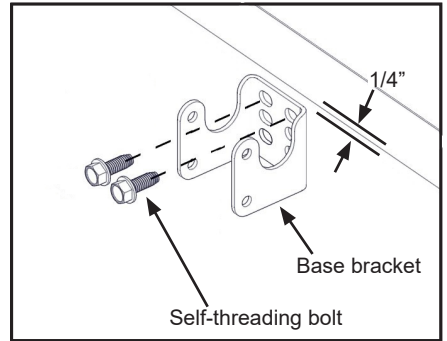

C. Place remaining base brackets 1/4" down from top of box, drill (2) 5/16" holes and secure with 3/8" x 1" self-threading bolts.

D. Align lower hole in upright with lower hole in base bracket. Assemble with clevis and bow-tie pins. Leave tarp stop in open position for now.

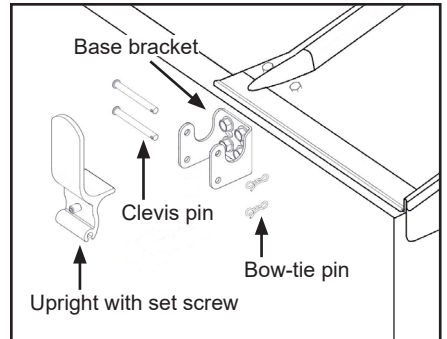

E. Repeat Step 8D for remaining tarp stops.

NOTE: Install uprights with set screw at front and rear.

NOTE: Flexible uprights are compression fit.

NOTE: If installing rubber uprights, drill 5/16" hole through rubber in line with stationary tube at front and rear. Secure with 3/8" x 1-1/4" self-threading bolt.



9: MOUNTING LATCH PLATE

NOTE: Ensure latch plate is longer than tarp, then cut as needed to conform to box.

NOTE: For stainless steel hardware, see page 2 for bolting procedures.

A. Mount latch plate on side of box opposite from tarp stops 0 to 3" down from top of box rail. Ensure latch plate is flush at each end of box.

NOTE: For radius corners mount latch plate where radius begins.

Tip: Use C-clamps to hold latch plate in place.

B. Using groove line on latch plate as center point, drill $5/16$ " holes in following locations: first bolt $1-1/2$ " in from ends and joints, second bolt 12" in from ends and joints and remaining bolts spaced 24" apart. Secure with $3/8$ " x 1" self-threading bolts as you go.

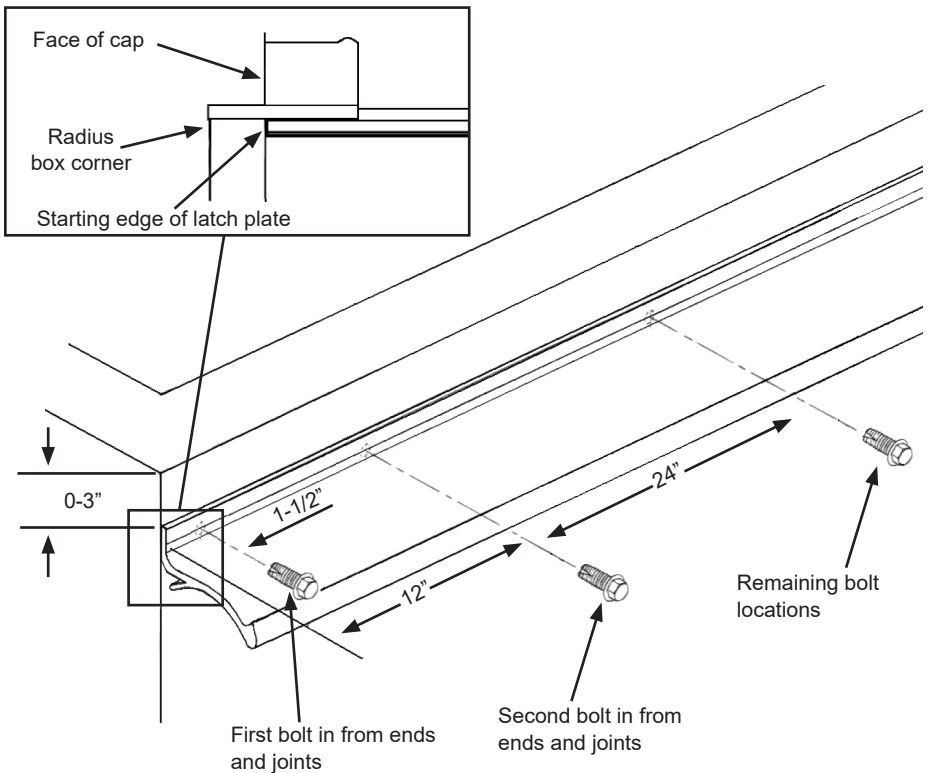

10: ASSEMBLING TUBES

NOTE: This step is for kits with multiple roll and stationary tube sections.

A. Insert swedged end of roll tube into full end of other roll tube. Align tubes, weld, allow to cool and grind smooth.

B. Insert swedged end of stationary tube into full end of other stationary tube. Align tubes, weld, allow to cool and grind smooth.

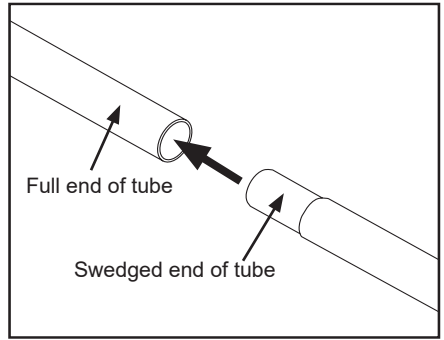

11: ATTACHING ROLL TUBE TO TARP

Perform one of the following to install roll tube:

NOTE: Check included electric conversion instructions for alternative tube measurements if applicable.

VERTICAL WALL BOX

A. Roll tube length is total of top outside box length, plus distance to standoff **minus 2"**. Cut roll tube at front, removing swaged end. Grind edges smooth.

B. On clean floor, lay tarp out flat and slide roll tube into large pocket with splined end to rear.

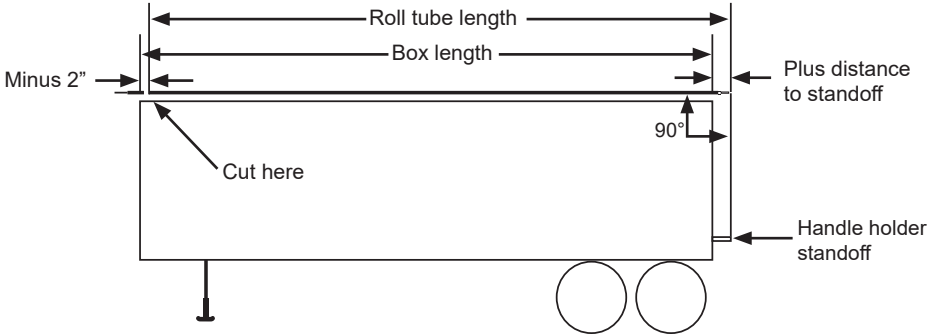

SLANT WALL BOX

A. Roll tube length is total of top outside box length, plus distance of slant and standoff **minus 2"**. Cut roll tube at front, removing swaged end. Grind edges smooth.

B. On clean floor, lay tarp out flat and slide roll tube into large pocket with splined end to rear.

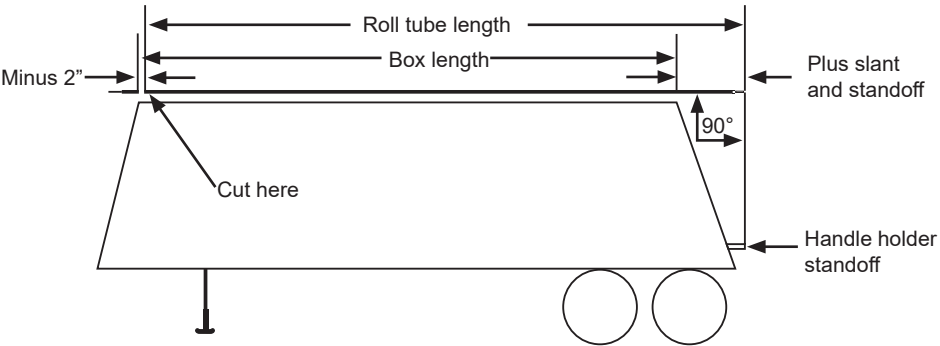

12: ATTACHING STATIONARY TUBE TO TARP

A. Install end plug into full end of stationary tube. Insert stationary tube end with end plug into small pocket on tarp.

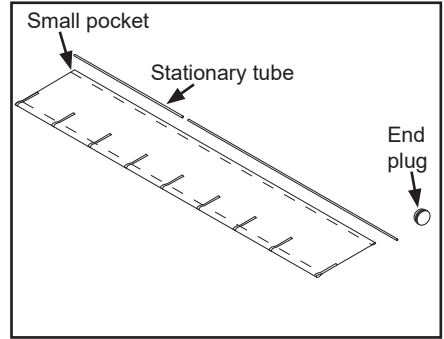

B. Extend stationary tube 1/4" beyond edge of tarp. Drill 7/32" hole and insert drive rivet. Ensure it is fully seated and set with hammer.

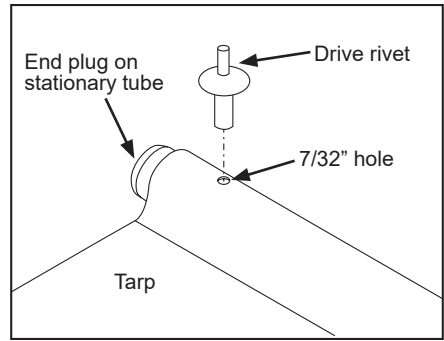

C. Pull tarp by hand to stretch tight along stationary tube. Drill 7/32" hole and insert drive rivet. Ensure it is fully seated and set with hammer.

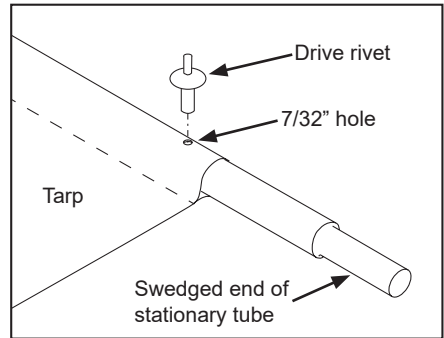

NOTE: Tarp is designed to be stretched to minimize wrinkles.

D. Cut stationary tube 1/4" beyond edge of tarp. Grind smooth, then install end plug.

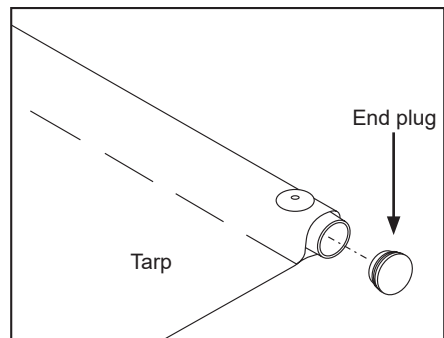

13: INSTALLING TARP ASSEMBLY

NOTE: If applicable, assemble ridge pole to tarp prior to placing tarp onto box.

A. Roll tarp assembly by hand to open position, roll tube to stationary tube.

Perform one of the following to finish installing tarp assembly:

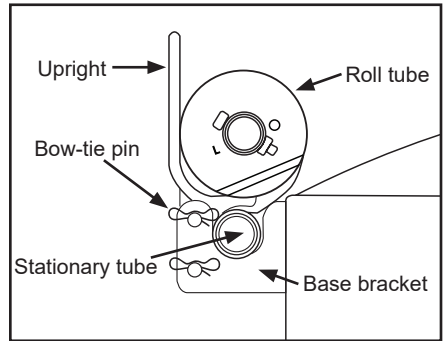

QUICK RELEASE TARP STOPS

- B. Place stationary tube into base brackets.
- C. Center assembly from front to rear of box. Be careful not to let tarp roll off box.
- D. Swing upright up and secure with clevis and bow-tie pins.
- E. Repeat Step 13D for remaining tarp stops.
- F. Tighten fasteners at front and rear tarp stops.

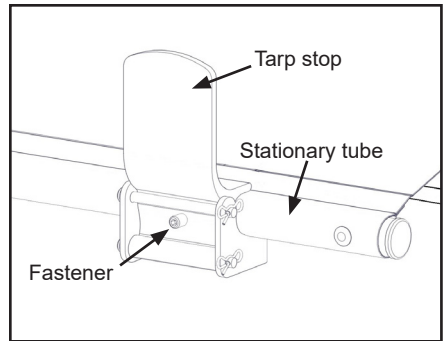

IMPORTANT: Fasteners prevent tube and tarp from sliding.

BOLT-ON TARP STOPS

- B. Center assembly from front to rear of box. Be careful not to let tarp roll off box.
- C. On tarp stops side, allow stationary tube to hang about 3" down from top of box.
- D. Position tarp stop over stationary tube at previously marked locations, drill (2) 5/16" holes through tarp and box then secure with 3/8" x 1" self-threading bolts.
- E. Repeat Step 13D for remaining tarp stops.

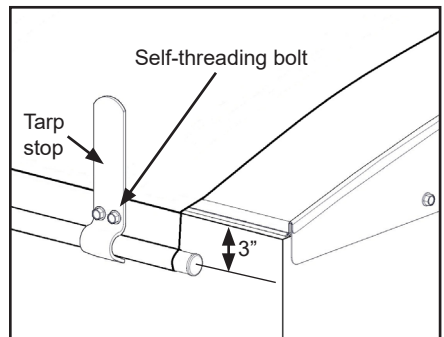

14: INSTALLING U-CLAMP ASSEMBLY

Refer to included electric conversion instructions if applicable.

A. Unroll tarp by hand to other side of box and let tarp hang down.

B. Adjust roll tube 1" from front of box and 3 to 5" from rear of box.

NOTE: Ensure tarp is still centered from front to back of box and make adjustments as needed.

C. Center U-clamp on first tarp strap on non-drive side. Secure with screw on crease at bottom of tarp pocket.

NOTE: Screw length varies depending on in-roll tube return.

NOTE: Non-drive side is opposite of tarp motor or crank handle.

D. Pull tarp by hand to stretch tight along roll tube and install U-clamp on last tarp strap on drive side.

E. Install U-clamp on remaining tarp straps.

Tip: Ensure clips are straight to prevent wrinkling.

NOTE: Driver bit may leave a sharp edge on head of screws, deburr if needed.

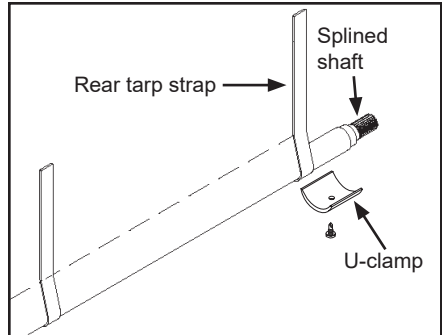
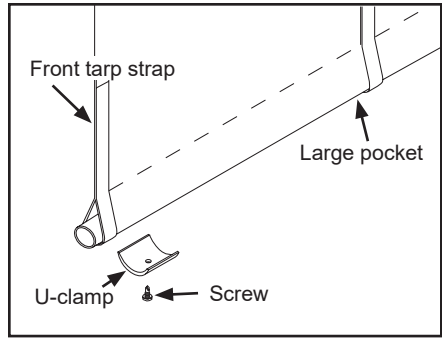
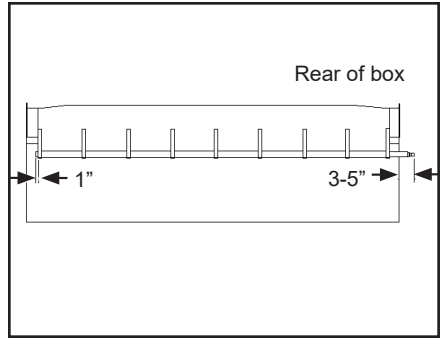

15: INSTALLING IN-ROLL TUBE BUNGEE RETURN

Perform the following to install the In-Roll Tube Bungee Return or use included return instructions if applicable.

NOTE: Install return on non-drive side (opposite side of tarp motor or crank handle).

NOTE: For stainless steel hardware, see page 2 for bolting procedures.

A. Unfold assembly, align open ends and connect tubes together.

B. Carefully insert return assembly into roll tube. Gently tap end plug into roll tube.

Tip: Rotate roll tube with screws on top for easier insertion of return.

C. Use hole in end plug to insert #8 x 1/2" self-drilling Phillips screw at end of roll tube.

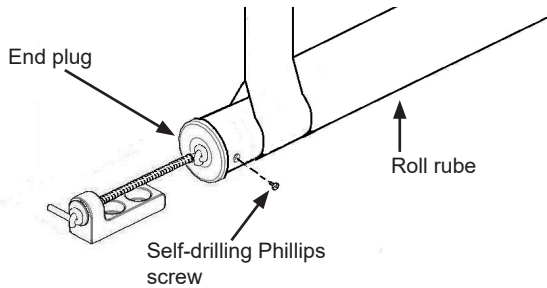

NOTE: Cable should follow a natural path on top of end cap without interference from edge of tarp or wind deflector. Ensure cable does not get caught on corner of end cap or latch plate.

D. Place guide 1/2" back from edge of latch plate. Mark and drill (2) 5/16" holes. Secure guide with 3/8" x 1" bolts, flat washers, lock washers and nuts.

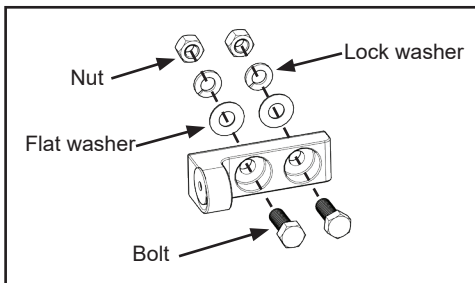
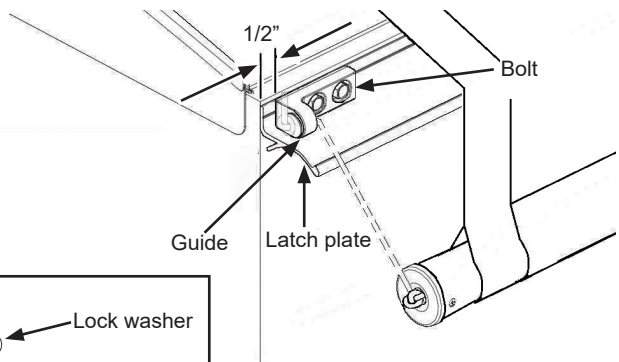

16: ASSEMBLING CRANK HANDLE

- A. Align hole in non-spline end of U-joint with single hole end of upper handle.
- B. Angle spline end 90° to handle. Tap U-joint onto upper handle with rubber mallet until holes line up.
- C. Secure with spring pin.

Tip: U-joint and upper handle are designed to fit tight. A coating of grease will ease this process.

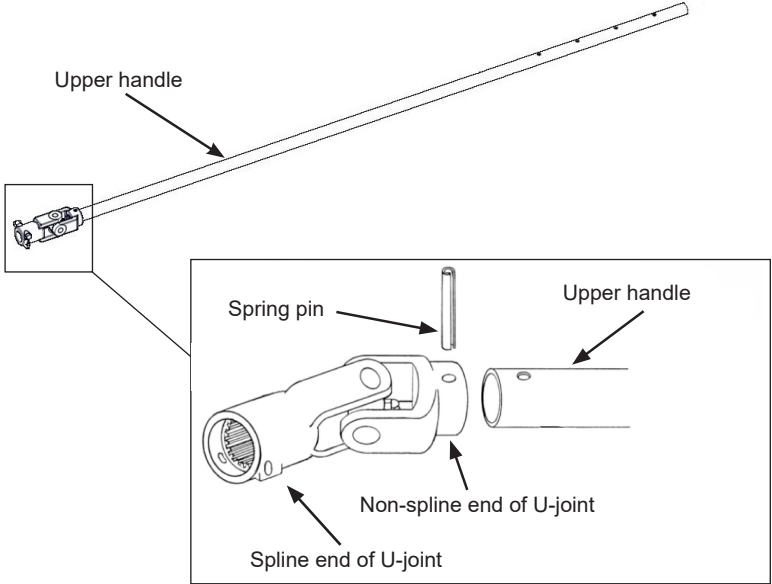

16: ASSEMBLING CRANK HANDLE (Continued)

D. Insert lower handle into upper handle selecting 1 of 4 holes according to desired length. Align holes and secure with $3/8"$ x $1-3/4"$ bolt and nut.

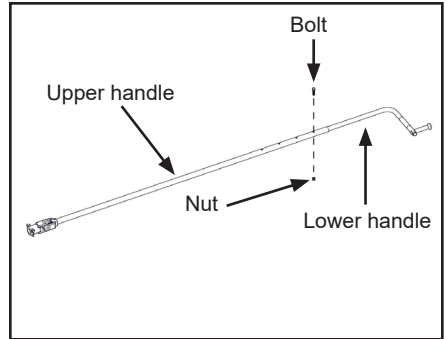

E. With roll tube hanging down on latch plate side, slide U-joint onto spline and secure with lock pin.

IMPORTANT: Never open or close tarp without U-joint securely fastened to spline shaft with lock pin.

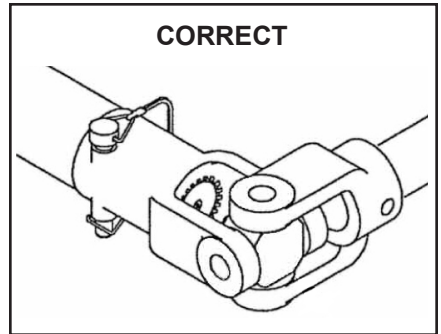

F. Ensure U-joint is in correct position for maximum strength when locked at 90° angle. Make correction if needed.

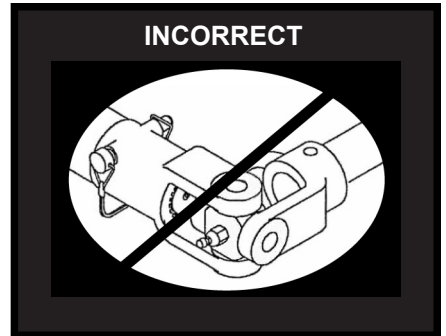

G. Ensure lock pin is in correct position around spline shaft. Make correction if needed.

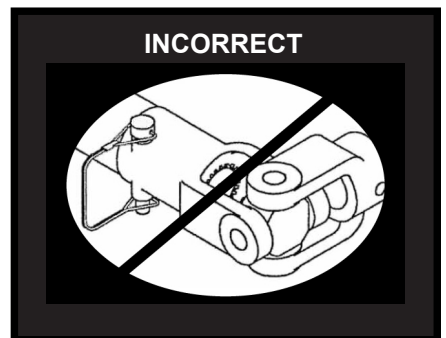

16: ASSEMBLING CRANK HANDLE (Continued)

H. Crank roll tube up tight under latch plate, hold and bring handle straight down to grade. There should be about 18" (6" for Grain Carts) of clearance from handle to grade. Adjust handle length if needed.

NOTE: On slant boxes, handle must be at a 90° angle.

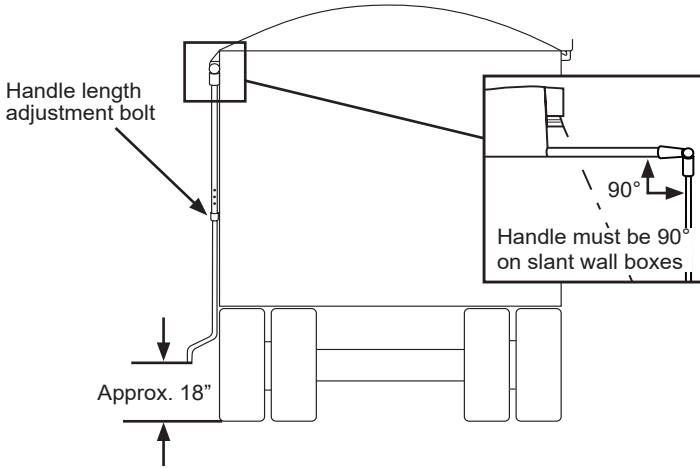

17: MOUNTING HANDLE HOLDER

For Grain Carts, refer to included handle holder extension instructions.

A. Crank roll tube up under latch plate then lower handle to a vertical position and lift toward center of box to mark your choice of location for handle holder.

NOTE: Handle holder should be mounted above curved portion on handle.

B. Use standoff as template to mark and drill (2) 5/16" holes into box then secure with 3/8" x 1" hex bolts, flat washers, lock washers and nuts.

C. Attach handle holder to standoff using 1/2" x 1" flange bolt with spacer.

D. Locate and clean suitable positions to apply caution and important stickers.

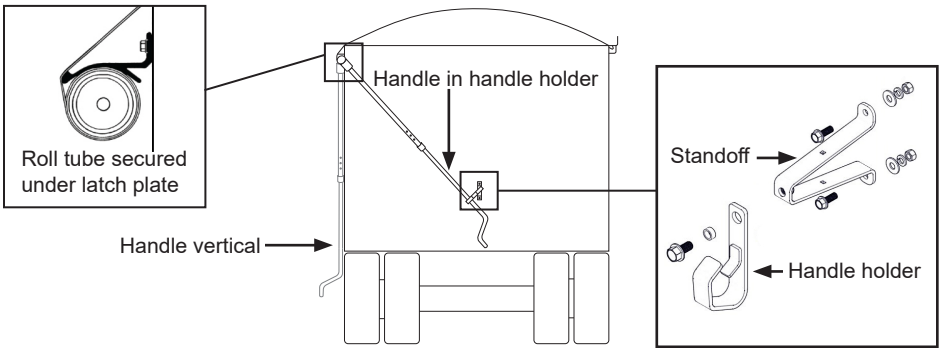

18: TENSIONING TARP

A. Ensure roll tube is secured under latch plate and lift handle into handle holder. Pressure required to place handle into holder depends on length of handle:

- 8' = 25 lbs.
- 10' = 20 lbs.
- 12' = 15 lbs.

IMPORTANT: Maintain recommended tension or excessive tarp wear may occur.

NOTE: To adjust tension, unroll tarp and remove all tension. Rotate handle 1 to 2 teeth, reassemble and check tension. Repeat until proper tension is achieved.

TROUBLESHOOTING

PROBLEM

Tarp sags in middle area.

- Bows may be spaced too far apart, bent, or adjusted too low. Self-threading bolt that secures bow height adjustment may be missing.
- Missing or loose ridge strap.

Holes or tears in tarp.

- Contact your local Agri-Cover dealer for replacement tarp or tarp repair kit.
- When new tarp or parts are needed replace with original Agri-Cover parts.

SOLUTION

OPERATION

TO CLOSE

A. Use both hands to remove crank handle from holder. Extend crank handle to a comfortable operating position.

B. Roll tarp to completely closed position.

C. Push crank handle into holder.

TO OPEN

A. Use both hands to remove crank handle from holder. Extend crank handle to a comfortable operating position.

B. Roll tarp to completely open position.

NOTE: Completely open is when tarp roll touches tarp stops. Attempting to roll tarp past open position could cause damage to tarp stops, tubes and tarp.

C. Push crank handle into holder.

INSPECTION AND MAINTENANCE

Periodic preventive maintenance should be practiced:

- Inspect tarp and hardware for abrasions or loosened bolts that may need adjustment. Adjust tension when needed. Tarp must be kept to a recommended tension setting equally on both ends, or excessive tarp wear may occur.
- Tarp should always operate as well as when first installed. Make all appropriate repairs or adjustments immediately before serious damage occurs.
- Check the tightness of mounting bolts and electrical connections, remove any dirt or corrosion that may have accumulated on the electrical connections.
- Always use genuine Agri-Cover, Inc. replacement parts, use serial number to easily order replacement tarp.

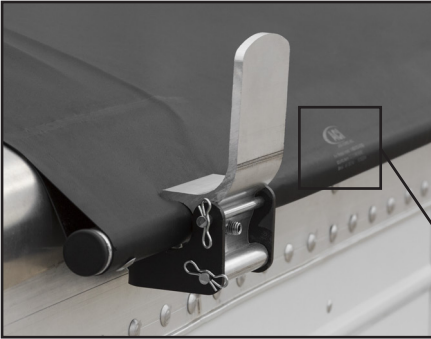

Serial number is located at rear of tarp on stationary tube side



MANUFACTURER'S LIMITED WARRANTY

Agri-Cover, Inc. extends the following Limited Warranty on its AGRI-COVER® Side Locking Tarp:

Agri-Cover, Inc. warrants its AGRI-COVER® Side Locking Tarp to be free from defects in material and workmanship under normal use for one (1) year from date of manufacture unless accompanied by proof of purchase. This Limited Warranty does not cover any failure due to abuse, misuse, alteration, neglect, improper assembly or installation, or improper maintenance.

ANY IMPLIED WARRANTY APPLICABLE TO THE AGRI-COVER® SIDE LOCKING TARP IS LIMITED IN DURATION TO ONE YEAR FROM THE DATE OF MANUFACTURE UNLESS ACCOMPANIED BY PROOF OF PURCHASE. Agri-Cover Inc.'s sole obligation under this Limited Warranty or any implied warranty is limited to the repair or replacement at its option, of defective parts only. No labor or service allowance is given or implied. IN NO EVENT SHALL AGRI-COVER, INC. BE LIABLE FOR INCIDENTAL, CONSEQUENTIAL, OR SPECIAL DAMAGES. EXPRESSLY DISCLAIMS ANY AND ALL IMPLIED WARRANTIES OF MERCHANTABILITY, AND THERE ARE NO WARRANTIES WHICH EXTEND BEYOND THE LIMITED WARRANTY DESCRIPTION CONTAINED HEREIN.

For warranty, have serial number ready and fill out the warranty claim form at agricover.com/warrantyclaim or call Customer Service Department at 800-233-4655 to determine if only a replacement part is needed or if the tarp needs to be returned for inspection and repair. Goods to be returned must have a pre-authorized RA # (Return Authorization Number) – obtained by calling the number above. Mark the number on the package and ship it freight prepaid to address below. Agri-Cover will pay freight to return goods to sender.

This Limited Warranty gives you specific legal rights and you may have other rights, which vary, from state to state.

For replacement parts shop at agricoverparts.com or call Customer Service at 800-233-4655.



Agri-Cover, Inc.
Customer Service Dept
3000 Hwy 281 SE
Jamestown, ND 58401
Phone: 800-233-4655

Hours: 8:00 am - 5:00 pm CST Monday through Friday, except Holidays