



GRAIN BAG LOADER INSTRUCTIONS

Use these special instructions to install cable ratchet holder bracket, end caps, bows, extensions and handle holder.

NOTICE TO INSTALLER: Even if familiar with product, read special instructions prior to installation as improvements may be made without notice. Always handle components with care. When done, these special instructions must be given to the consumer.

This tarp requires a REVERSE ROLL installation. Use SRT-2® Owner's Manual for reverse roll and all remaining installation procedures.

NOTICE TO CONSUMER: Before using this product, read instructions. Save these instructions for future reference.

NOTE: Actual parts may vary from illustrations.



Questions? 800-233-4655
agricover.com

PREPARATION

COMPONENTS

- (2) Front brackets with hardware
- (2) Side brackets with hardware

TOOLS NEEDED

- Drill with 3/8", 5/16" and 9/16" bits
- 1-1/2" Hole saw (front access platform kits)
- Metal cutting tool
- Tape measure or ruler
- Metal grinding tool
- Protective eyewear

1: ASSEMBLE RATCHET MOUNT BRACKET

A. Align (2) square holes in ends of front and side brackets. Insert (2) 3/8" x 1" carriage bolts and secure with nuts, then tighten.

B. Repeat for remaining ratchet mount bracket with side bracket rotated 180°.

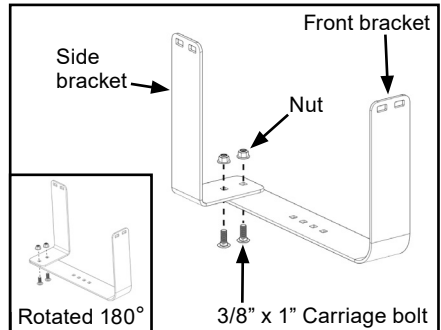

2: INSTALL RATCHET MOUNT BRACKET

NOTE: Illustrations depict view of front left corner.

A. Set end cap on box and check fit at corners. Cut end cap at corner to clear bolt and corner gusset on box or drill 9/16" hole for bolt to pass through.

B. Drill 5/16" hole near sealing rib and insert 5/16" x 1-1/2" carriage bolt. Place (2) 3/8" flat washers under cap to serve as spacers. Secure with flat washer, lock washer and nut, then tighten. Repeat at opposite corner.

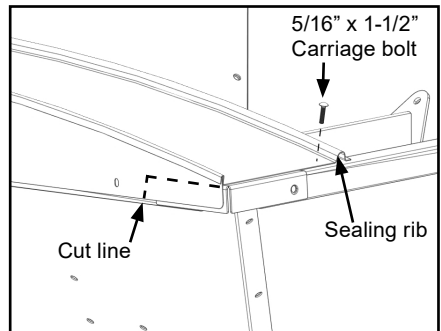

2: INSTALL RATCHET MOUNT BRACKET (Continued)

C. At corner of box, position bracket level against inner frame. Use holes in bracket to mark (2) hole locations for front bracket and one location for side bracket.

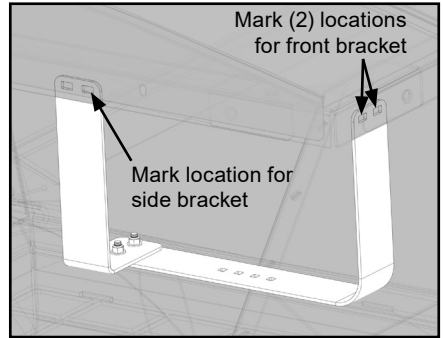

D. Drill $3/8$ " hole at each mark then mount bracket with (2) $3/8$ " x $1-1/2$ " carriage bolts in front location and $3/8$ " x 1 " hex bolt in side location. Secure all bolts with flat washer, lock washer and nut, then tighten.

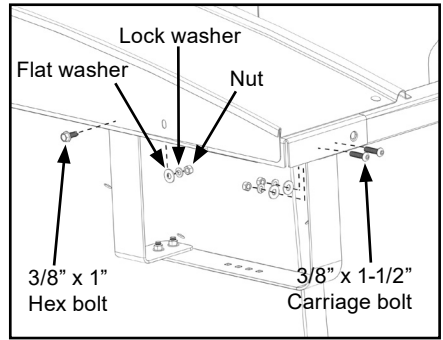

E. Mount cable tension ratchet onto bracket with (2) $3/8$ " x 1 " self-threading bolts and secure with nuts, then tighten.

F. Repeat Step 2 for remaining end cap.

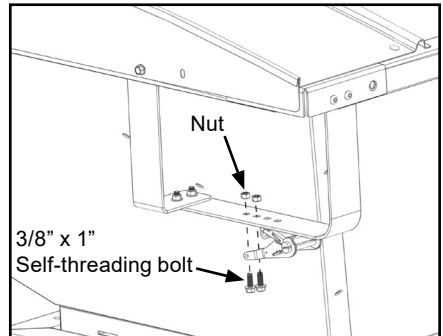

3: INSTALL SPECIAL BOW & EXTENSION

A. Position bow pocket inside slanted wall flush with top of box then use holes in bow pocket as a template to drill (2) 5/16" holes. Insert (2) 3/8" x 1" self-threading bolts and secure with lock washers, flat washers and nuts, then tighten. Repeat on opposite side of box.

B. Insert bow extension into pocket and bend extension down as needed. Repeat procedure for bow. Refer to standard instructions to finish adjusting and setting bow height.

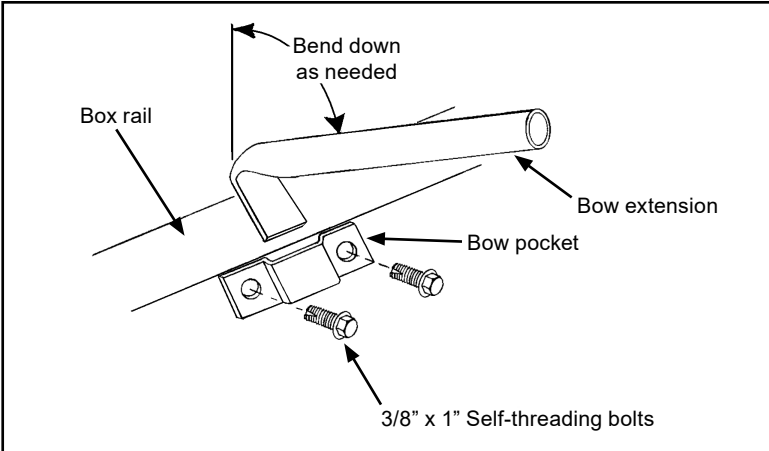

4: MOUNT HANDLE HOLDER

To install handle holder, perform one of the following:

FRONT ACCESS PLATFORM KITS

These kits **WILL NOT** come with a mounting bracket, a special handle holder bracket or a swivel handle holder.



Grain bag loader with front access platform

A. Drill 1-1/2" hole 7-3/8" from side edge and 1-1/4" up from bottom of platform (all measurements to center of hole). This 1-1/2" hole is used to hold the handle when not in use.

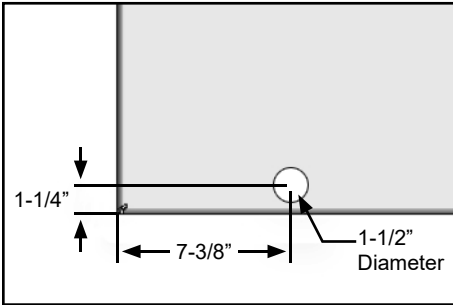

4: MOUNT HANDLE HOLDER (Continued)

SIDE ACCESS PLATFORM/NO ACCESS PLATFORM KITS

These kits **WILL** come with a mounting bracket, a special handle holder bracket and a swivel handle holder.



Grain bag loader without access platform

A. Align holes in mounting bracket with pre-existing holes in machine then secure with (2) 3/8" x 1-1/2" carriage bolts, flat washers, lock washers and nuts, then tighten.

NOTE: If mounting bracket is already installed on machine skip to next step.

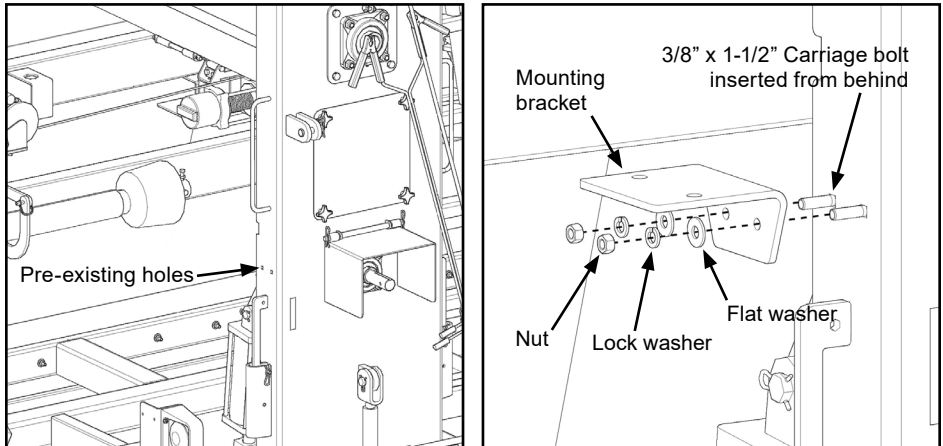

4: MOUNT HANDLE HOLDER (Continued)

B. Align holes in special handle holder bracket to mounting bracket then secure with (2) 1/2" x 1-3/4" hex bolts, flat washers and lock nuts, then tighten.

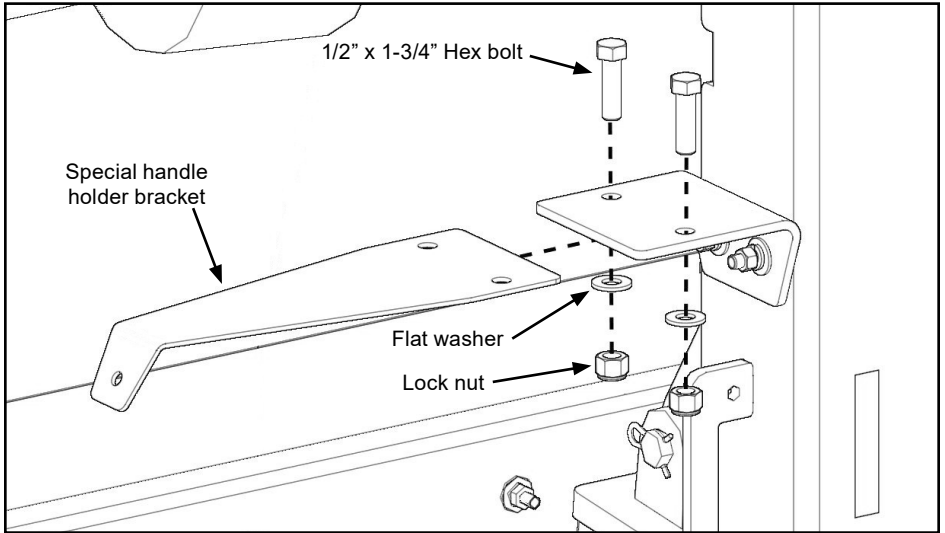

C. Mount handle holder to special handle holder bracket with 3/8" x 1" hex bolt with threadlock adhesive, flat washer and nut. Turn nut onto bolt and leave loose enough to allow holder to swivel when mounting handle.

