

FULL WRAP RADIUS END CAP INSTALLATION FOR TIMPTE TRAILER

Use these instructions to install weather seal and end caps. Read and follow these instructions along with the standard instructions carefully before installing or using tarp system.

NOTICE TO INSTALLER: Even if familiar with hardware, read instructions prior to installation as improvements may be made without notice. Always handle components with care. If you have questions or problems, call customer service. When done, these instructions must be given to the consumer.

NOTICE TO CONSUMER: Before using this product, read special instructions. Save these instructions for future reference.



Questions? 800-233-4655
agricover.com

PREPARATION

COMPONENTS

- (8) Spacers
- Front end cap with hardware
- Rear end cap with hardware
- "D" weather seal
- Edge guard

TOOLS NEEDED

- Drill with 5/16" bit
- 9/16" Socket and wrench
- T45 bit (included with kit)
- Alcohol
- Tape
- Protective eyewear

NOTE: End cap shown has metal filler. If end cap does not have metal filler, it is installed in similar manner.

1: ASSEMBLE FRONT END CAP

NOTE: Front end cap will have radius corners.

NOTE: For best adhesion, ensure air and surface temperatures are above 60° F.

A. Tape a spacer on inside edge of end cap over each hole.

B. Apply edge guard to inside edges of end cap and gently tap in place.

C. Clean surface with alcohol, then adhere "D" weather seal along inside edge of end cap between spacers and bottom edge of end cap continuous from end to end.

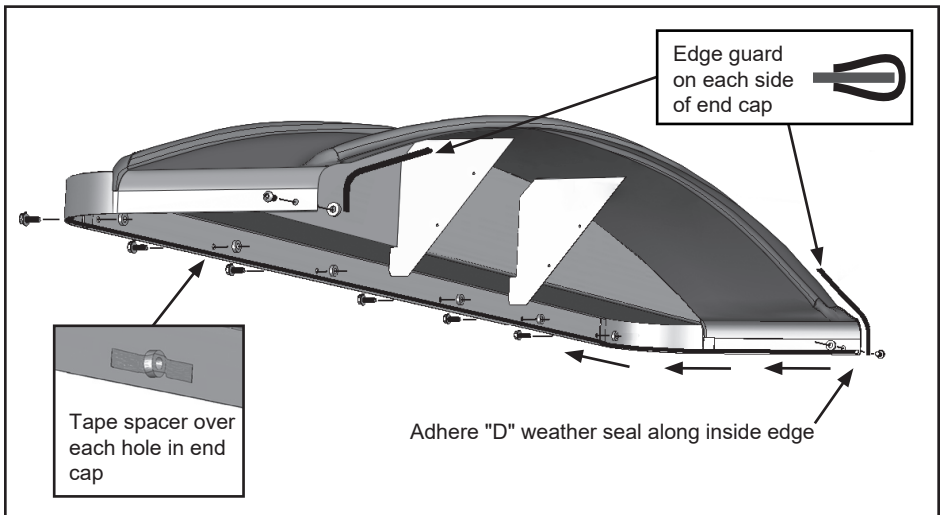

2: ATTACH END CAP TO BOX

- A. Set end cap on front of box and center.
- B. Use holes across front of end cap as template to drill (6) 5/16" holes into box.
- C. Turn (6) 3/8" x 1" self-threading hex bolts into each hole then tighten using 9/16" wrench.

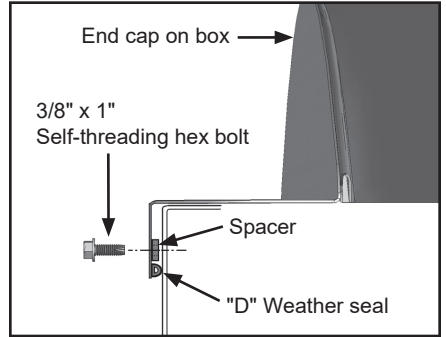

- D. Use hole in each side of end cap as template to drill 5/16" hole into box.
- E. Use T45 bit (included with kit) to turn 3/8" x 1" self-threading Torx head bolt into each hole.
- F. Repeat Steps 1-2 for rear end cap.

