

## TOP MOUNT BRACKET END CAP INSTRUCTIONS

Use these instructions to install end cap with Top Mount Brackets. Read and follow these instructions along with the standard instructions carefully before installing or using tarp system.

**NOTICE TO INSTALLER:** Even if familiar with hardware, read instructions prior to installation as improvements may be made without notice. Always handle components with care. If you have questions or problems, call customer service. When done, these instructions must be given to the consumer.

**NOTICE TO CONSUMER:** Before using this product, read safety and maintenance sections of these instructions. Save these instructions for future reference.

**NOTICE TO INSTALLER/CONSUMER:** Top Mount Brackets replace standard end cap brackets.



Questions? 800-233-4655  
agricover.com

# PREPARATION

## COMPONENTS

- (4) 3/8"-16 x 1" Stainless steel Allen button head bolt
- (4) 3/8" Stainless steel hex nuts
- (4) 3/8" Stainless steel lock washers
- (4) 3/8" x 7/8" Stainless steel flat washers
- (2) Top Mount Brackets (7" or 12")

## TOOLS NEEDED

- Ladder
- Drill with 3/8" bit
- Ratchet with 9/16" socket
- Eye protection

**NOTE:** Hardware appearance and components may vary.

# 1: MOUNTING END CAP WITH TOP MOUNT BRACKETS

A. Insert Top Mount Bracket under rear of end cap near sealing rib.

B. Place Top Mount Bracket with short leg on top of box and long leg under end cap. Use hole in short leg of bracket to mark drill location on top of box.

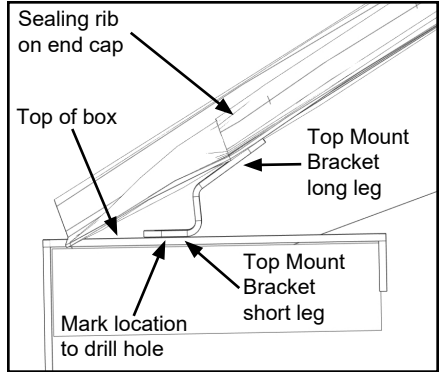

C. Drill 3/8" hole through location marked on top of box and insert bolt, flat washer, lock washer and tighten with nut.

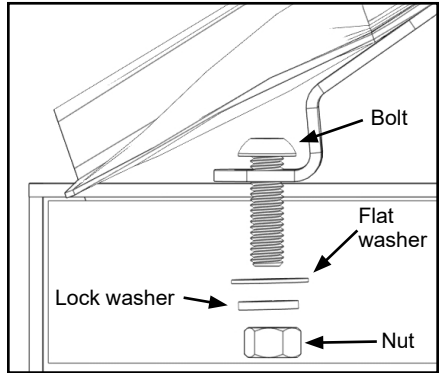

D. Mark hole location at low side of slotted hole in long leg under end cap. Drill 3/8" hole in end cap. Insert bolt, flat washer, lock washer and nut. Leave bolt loose for now.

E. Repeat for Top Mount Bracket on opposite side.

F. Refer to end cap mounting section in standard instructions to adjust end cap tilt angle.

G. Tighten bracket bolts with 9/16" socket.

