

FRONT MOUNT KIT INSTALLATION INSTRUCTIONS



2018-ON JEEP WRANGLER & 2020-ON JEEP GLADIATOR

NOTICE TO INSTALLER: Even if familiar with product, read these instructions prior to installation as improvements may be made without notice. Always handle components with care. When done, these instructions must be given to the consumer.

NOTICE TO CONSUMER: Before using this product, read instructions. Save these instructions for future reference.

PREPARATION

⚠ CAUTION: Front Mount is rated for SNOWSPORT® Utility Plow use only!

TOOLS NEEDED

- Ratchet and 13 mm socket
- 10 mm socket (Mojave only)
- Ft-lb torque wrench
- Protective eyewear

NOTE: Hardware appearance and components may vary.

⚠ CAUTION: Over torquing hardware may damage components.

NOTE: Periodically inspect hardware and components, perform maintenance as required.

1: PREPARING FOR INSTALLATION

A. On one side, remove (2) bolts securing skid plate with ratchet and 13 mm socket.

B. Repeat on opposite side.

C. Remove skid plate.

NOTE: Installer should return skid plate to owner.

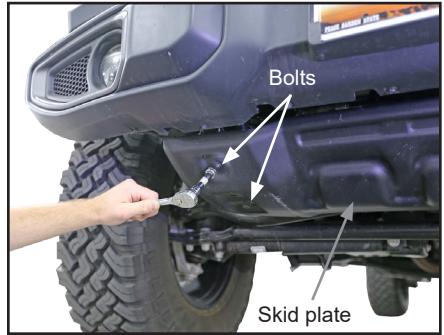

D. On one side, remove (2) inside skid plate bracket bolts with ratchet and 13 mm socket.

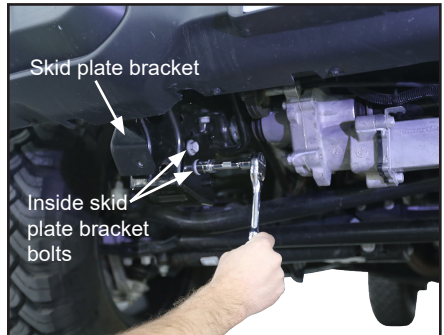

2: INSTALLING FRONT MOUNT

E. Remove (2) outside skid plate bracket bolts with ratchet and 13 mm socket.

F. Repeat Steps 1D-E on opposite side.

NOTE: Skid plate bracket removal may vary. For Mojave remote reservoir shocks, remove (2) 10 mm bolts. Save bolts to attach front mount.

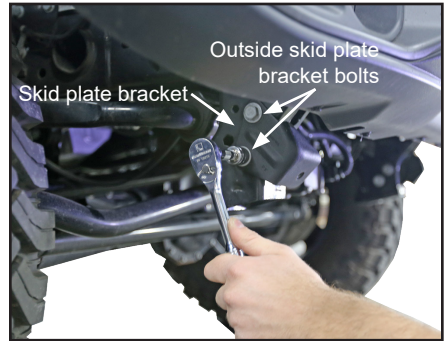

A. Install square hole spacer on 7/16" x 1-1/2" carriage bolt and insert through front-facing frame hole.

B. Repeat on opposite side.

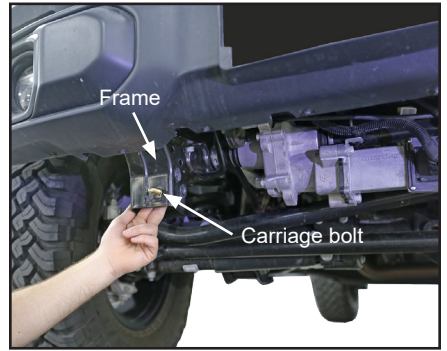

NOTE: We recommend performing this step with two people.

C. Lift front mount into position. Secure with serrated flange nuts. Finger tighten.

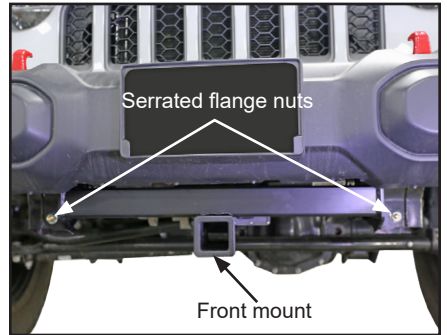

NOTE: 7/16" x 1-1/2" carriage bolt and hex-head cap screw placement may be reversed on some models, depending on threaded insert placement. Hex-head cap screw goes into threaded insert.

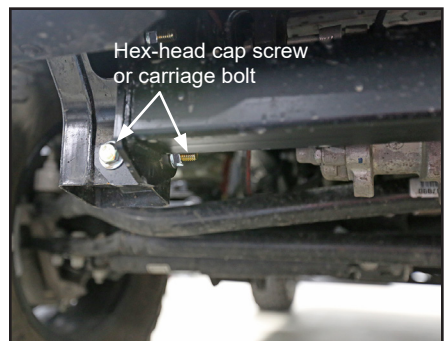

2: INSTALLING FRONT MOUNT (Continued)

D. On one side, install square hole spacer onto 7/16" x 1-1/2" carriage bolt, then insert carriage bolt into top frame hole and secure with serrated flange nut. Finger tighten.

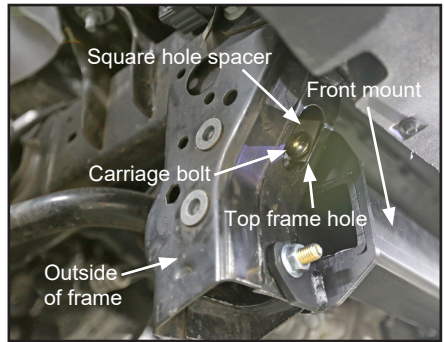

E. Repeat Step 2D with middle frame hole.

F. Place washer on hex-head cap screw and insert into threaded insert of frame. Finger tighten.

G. Repeat Steps 2D-F on opposite side.

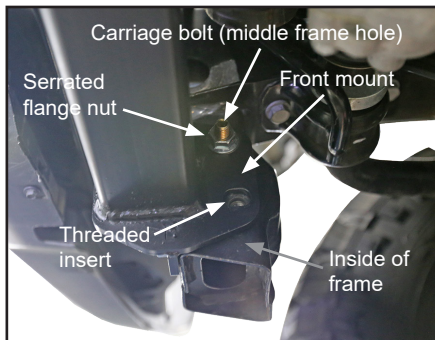

NOTE: For Mojave remote reservoir shock front mounts, use factory bolts and provided nylock flange nuts to secure with ratchet and 10 mm socket. Fully tighten.

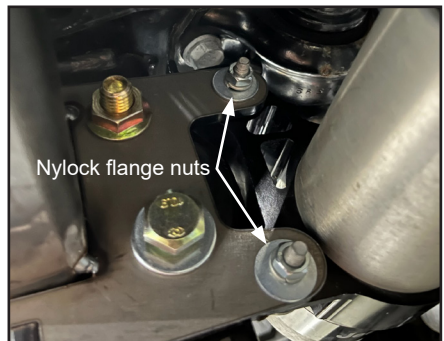

H. Torque all front mount hardware, beginning with front-facing fasteners.

- Torque 7/16" x 1-1/2" carriage bolts to 70 ft-lbs.
- Torque hex-head cap screws to 45 ft-lbs.