

OFFSET RATCHET BRACKET

Use these instructions to install offset ratchet brackets on select models. Read and follow these instructions along with the standard instructions carefully before installing or using tarp system.

NOTICE TO INSTALLER: Even if familiar with product, read special instructions prior to installation as improvements may be made without notice. Always handle components with care. If you have questions or problems, call customer service. When done, these instructions must be given to the consumer.

NOTICE TO CONSUMER: Before using this product, read instructions. Save these instructions for future reference.



Questions? 800-233-4655
agricover.com

PREPARATION

TOOLS NEEDED

- (2) 9/16 Wrench
- Protective eyewear

NOTE: Hardware appearance and components may vary.

1: INSTALLING BRACKET

NOTE: Bracket is offset to allow heads of carriage bolts to install between box wall and bracket. When inserting bolts, position bracket accordingly.

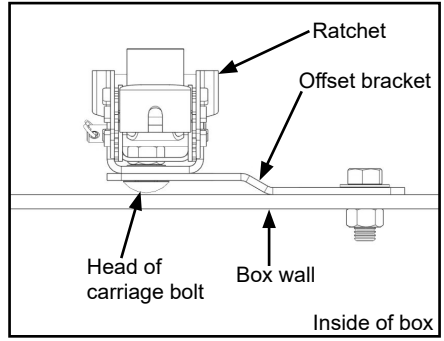

A. Insert 3/8" carriage bolts through slotted bracket holes and ratchet. Secure bolts with flat washer, lock washer and nut then tighten with 9/16" wrench.

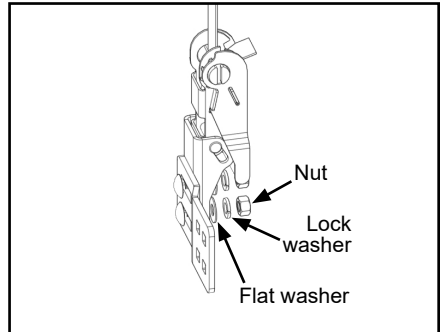

1: INSTALLING BRACKET

B. Attach bracket with ratchet to box wall using existing hardware from standard kit. Tighten with 9/16" wrenches.

NOTE: Inner bracket holes are used when mounting to front of box, outer bracket holes are used when mounting to rear of box.

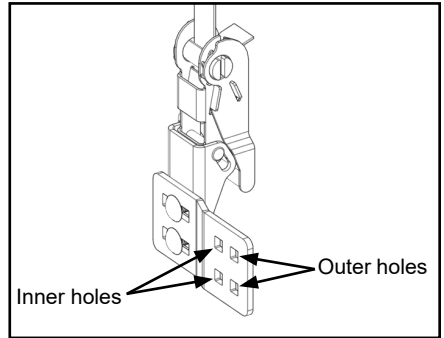

C. Refer to standard instructions for cable alignment.

D. Repeat for remaining bracket on opposite side then refer to standard instructions for remaining installation.

