

FULL WRAP END CAP INSTRUCTIONS

Use these instructions to install full wrap end caps. Read and follow these instructions along with the standard instructions carefully before installing or using tarp system.

NOTICE TO INSTALLER: Even if familiar with hardware, read instructions prior to installation as improvements may be made without notice. Always handle components with care. If you have questions or problems, call customer service. When done, these instructions must be given to the consumer.

NOTICE TO CONSUMER: Before using this product, read special instructions. Save these instructions for future reference.

NOTICE TO INSTALLER/CONSUMER: These instructions replace the weather seal and end cap steps in standard instructions.



Questions? 800-233-4655
agricover.com

PREPARATION

COMPONENTS

- Full wrap end cap with hardware
- Edge guards

TOOLS NEEDED

- Ladder
- Drill with 5/16" bit
- 9/16" Box wrench
- T45 bit (supplied)

NOTE: Hardware appearance and components may vary.

⚠ CAUTION: Over torquing hardware may damage components.

1: INSTALLING EDGE GUARD

A. Align split side of edge guard to inside raw edge of end cap and press to adhere.

B. Repeat at opposite side of end cap.

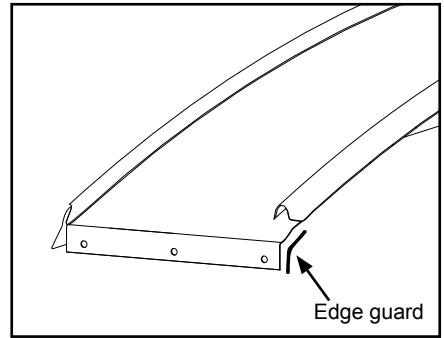

2: INSTALLING END CAP

A. Center end cap on front of box. On front face of end cap, drill (6) 5/16" holes into box wall at each factory hole location.

B. Turn 3/8" x 1" self-threading hex bolt into each hole with 9/16" box wrench.

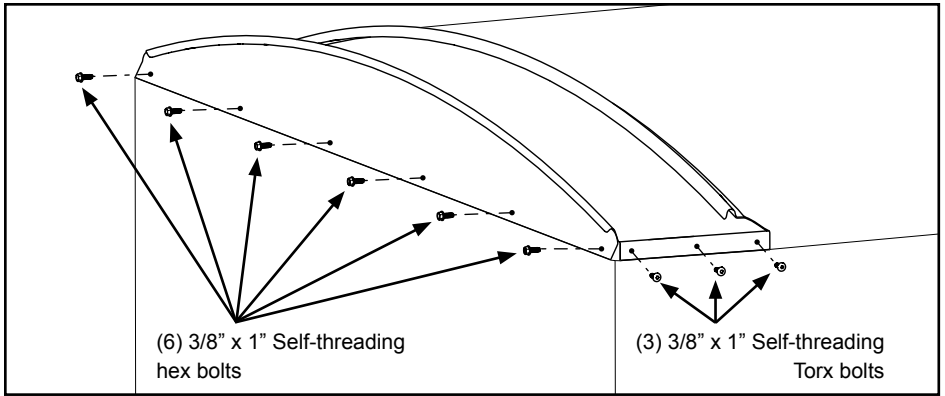

C. On each side of end cap, drill (3) 5/16" holes into box wall at each factory hole location.

D. Turn 3/8" x 1" self-threading Torx bolt into each hole using T45 bit supplied in kit.

