



## INSTALLATION INSTRUCTIONS

Thank you for purchasing ROCKSTAR™ Full Width Tow Flap. Agri-Cover, Inc. proudly manufactured this tow flap using superior quality materials and workmanship. With proper care, your tow flap will provide years of service and enjoyment.

**NOTICE TO INSTALLER:** Even if familiar with product, read instructions prior to installation as improvements may be made without notice. Always handle components with care. If you have questions or problems, call customer service. When done, these instructions must be given to the consumer.

**NOTICE TO CONSUMER:** Before using this product, read safety and maintenance section of these instructions. Save these instructions for future reference.

### FOR YOUR RECORDS

DATE PURCHASED: \_\_\_\_\_

WHERE PURCHASED: \_\_\_\_\_



Questions? 888-568-3709  
agricover.com

# PREPARATION

For additional installation assistance, go to [rockstarmudflaps.com](http://rockstarmudflaps.com) for install video.

## TOOLS NEEDED

- In-lbs Torque wrench with 3/16" Allen head socket
- Ratchet with 9/16" socket
- Cutting tool (dual exhaust only)
- Protective eyewear
- Drill with 11/32" drill bit (adjustable only)

**IMPORTANT:** Always remove tow flap when driving off road. Contact with obstacles may cause damage.

**NOTE:** Hardware appearance and components may vary.

**▲ CAUTION:** Over torquing hardware may damage components.

**▲ WARNING:** Ensure exhaust fumes are **NOT** directed or redirected toward vehicle or flaps and perforated regions are cut out for OEM dual exhaust vehicles, otherwise damage may occur. Optional heat shield available to protect flap from hot exhaust (PN 4006056).

**▲ CAUTION:** Always exercise caution when using a cutting tool.

## PARTS DIAGRAM:

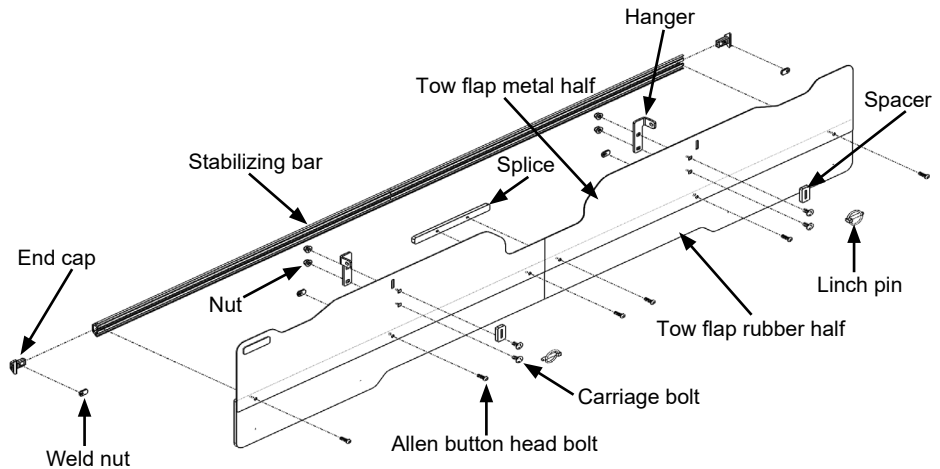

# 1: ASSEMBLING ADJUSTABLE RUBBER

**NOTE:** For adjustable tow flap installation perform Step 1. For standard tow flap installation proceed to Step 2.

**NOTE:** Always check ground clearance of flaps. Suggested clearance with a load is 3" minimum to prevent dragging. Install on vehicles with suspension modifications or oversized tires may exceed suggested clearance. Mud flaps still function, though performance may be affected.

A. Determine desired height by holding metal and rubber tow flap halves under the bumper. Drill out pin holes with 11/32" drill bit.

**NOTE:** If necessary, trim excess rubber above stabilizing bar.

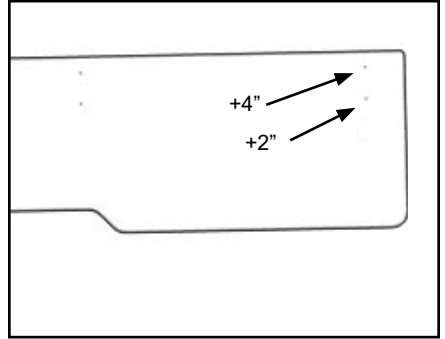

**NOTE:** Ensure decal is on driver side.

B. Insert Allen button head bolt through middle hole of metal tow flap half and rubber tow flap half, start weld nut.

**NOTE:** Ensure extended threads on weld nut are toward closed wall of stabilizing bar.

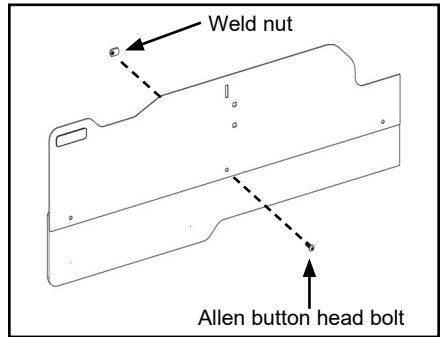

C. Insert weld nut into end cap aligning bolt holes.

**IMPORTANT:** Ensure extended threads on weld nut insert into end cap.

D. Insert end cap assembly into stabilizing bar.

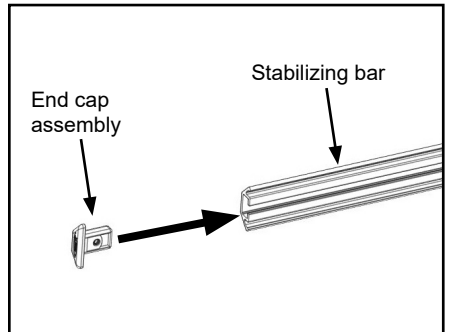
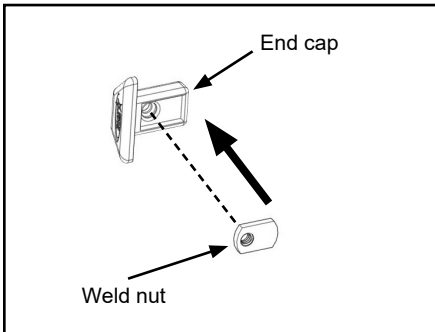

# 1: ASSEMBLING ADJUSTABLE RUBBER (Continued)

E. Slide stabilizing bar over weld nut ensuring stabilizing bar and inside of tow flap halves are flush.

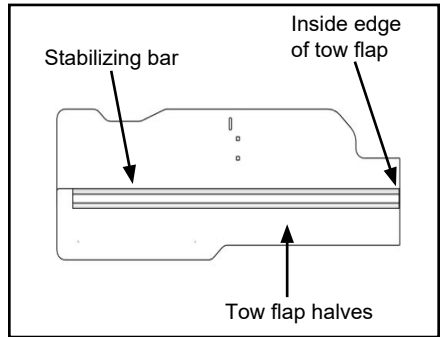
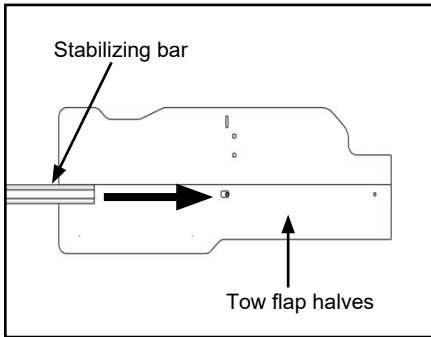

F. Insert Allen button head bolt through metal tow flap half and rubber tow flap half into end cap assembly in stabilizing bar.

G. Torque bolts to 100 in-lbs.

H. Repeat Steps 1 A-G with other tow flap half.

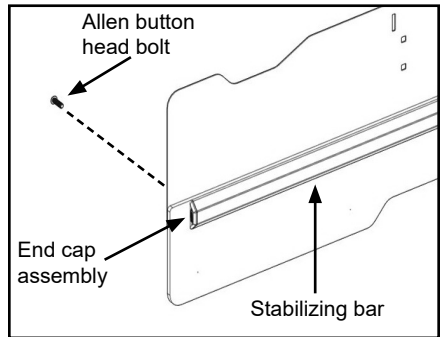

## 2: ASSEMBLING TOW FLAP

A. Insert hanger into vertical slot at top of one tow flap half. Secure with carriage bolts and nuts.

**NOTE:** Some models only require (1) carriage bolt.

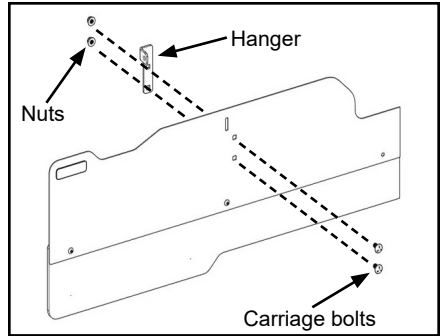

B. Insert splice into stabilizing bar on one tow flap half. Align bolt hole in splice with bolt hole in tow flap half. Secure with Allen button head bolt.

C. Torque bolt to 100 in-lbs.

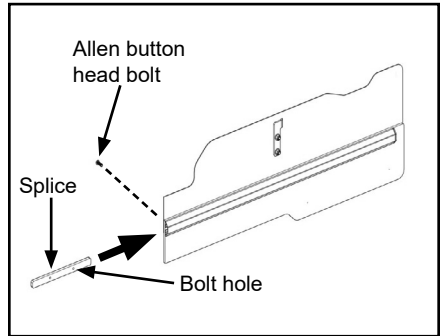

D. Repeat steps 2 A-C with other tow flap half.

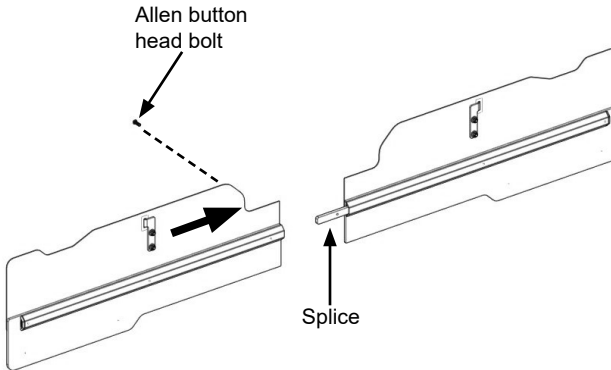

### 3: REMOVING EXHAUST CUTOUT

If your vehicle is equipped with OEM dual exhausts, perform the following to remove the exhaust cutouts. Otherwise, proceed to Step 4.

A. On one side, cut the top (2) attachment points of the perforated exhaust cutout.

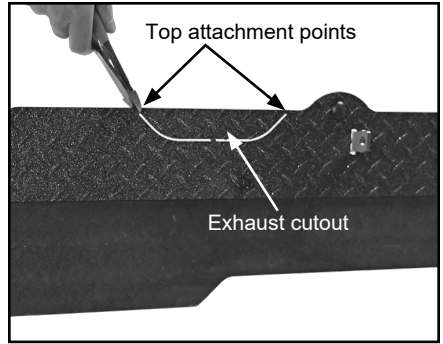

B. Bend exhaust cutout back and forth until the bottom attachment point of the perforated exhaust cutout snaps.

C. Repeat Steps 3A-B on opposite side.

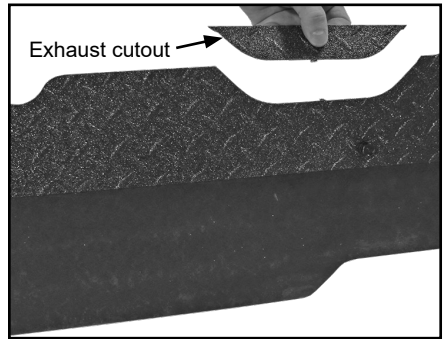
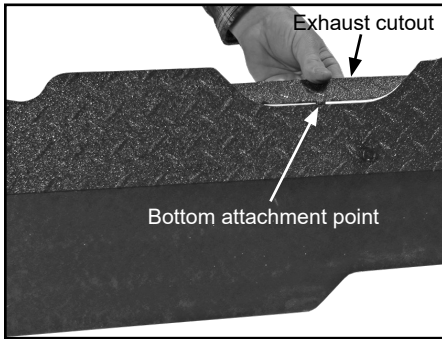

### 4: INSTALLING MOUNTING BRACKETS

A. Refer to special instructions for mounting bracket attachment.

## 5: INSTALLING TOW FLAP

- A. On one side, place spacer on hanger and insert through back of mounting bracket.
- B. Repeat on opposite side.

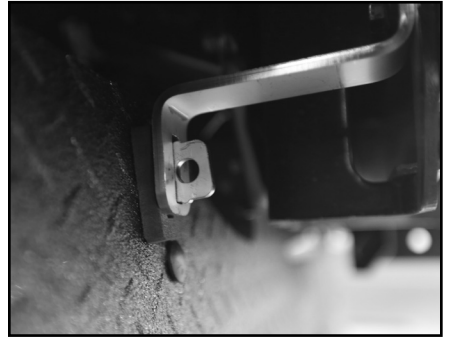
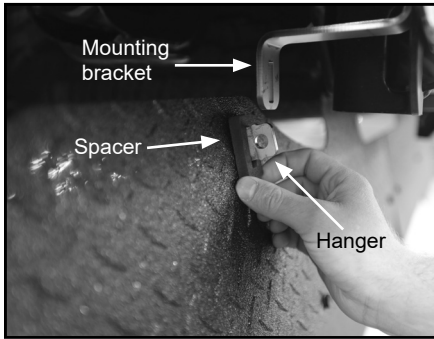

- C. Secure tow flap to mounting bracket with linch pin at both bracket locations.
- D. Adjust mounting brackets if necessary, then fully tighten bolts.

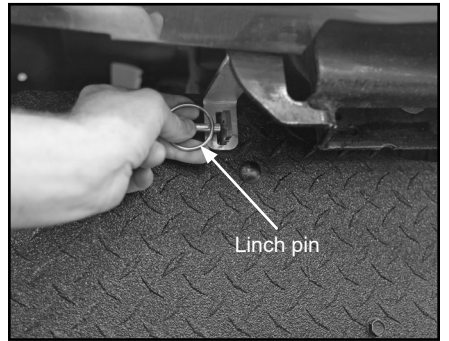

## SAFETY AND MAINTENANCE

The operator can perform most of inspection and maintenance. It may be necessary to review the installation instructions.

- Periodically check all bolts and nuts, retighten if needed.
- Always remove tow flap before entering automatic car wash systems.
- Always remove tow flap when driving off road. Contact with obstacles may cause damage.
- Remove tow flap when not towing to improve fuel efficiency.
- DO NOT hook up anything to tow flaps.
- If tow flap has been damaged, replace with new one.

**NOTE:** Inspection and/or maintenance should be performed anytime a malfunction is observed or suspected. If you need assistance inspecting and/or servicing your tow flap, call customer service at 888-568-3709. Always use original equipment replacement parts for your tow flap.

# MANUFACTURER'S LIMITED WARRANTY

Agri-Cover, Inc. extends the following (1) year Limited Warranty for the ROCKSTAR™ Full Width Tow Flap:

Agri-Cover, Inc. warrants a period of one (1) year from the date of manufacture that its ROCKSTAR™ Full Width Tow Flap is free from defects in workmanship, under normal use for the truck model it was intended for. This Limited Warranty does not cover any damage due to accident, abuse, misuse, alteration, neglect, improper installation, or ordinary wear and tear.

Agri-Cover, Inc.'s sole obligation under this Limited Warranty is limited to the repair or replacement at its option, of defective parts only. No labor or service allowance is given or implied. IN NO EVENT SHALL AGRI-COVER, INC. BE LIABLE FOR INCIDENTAL, CONSEQUENTIAL, OR SPECIAL DAMAGES. AGRI-COVER, INC. EXPRESSLY DISCLAIMS ANY AND ALL IMPLIED WARRANTIES OF MERCHANTABILITY, AND THERE ARE NO WARRANTIES WHICH EXTEND BEYOND THE LIMITED WARRANTY DESCRIPTION CONTAINED HEREIN.

For warranty, have serial number ready and fill out the warranty claim form at [agricover.com/warrantyclaim](http://agricover.com/warrantyclaim) or call Customer Service Department at 888-568-3709 to determine if only a replacement part is needed or if the mud flaps needs to be returned for inspection and repair. Goods to be returned must have a pre-authorized RA # (Return Authorization Number) - obtained by calling the number above. Mark the number on the package and ship it freight prepaid to address below. Agri-Cover, Inc. will pay freight to return goods to sender.

This Limited Warranty gives you specific legal rights and you may have other rights, which vary, from state to state.

For replacement parts shop at [mudflapparts.com](http://mudflapparts.com) or call Customer Service at 888-568-3709.



Agri-Cover, Inc.  
Customer Service Dept  
3000 Hwy 281 SE  
Jamestown, ND 58401  
Phone: 888-568-3709

**Hours: 8:00 am - 5:00 pm CST Monday through Friday, except Holidays**