

# HITCH MOUNTED MUD FLAPS SPECIAL CUTTING INSTRUCTIONS

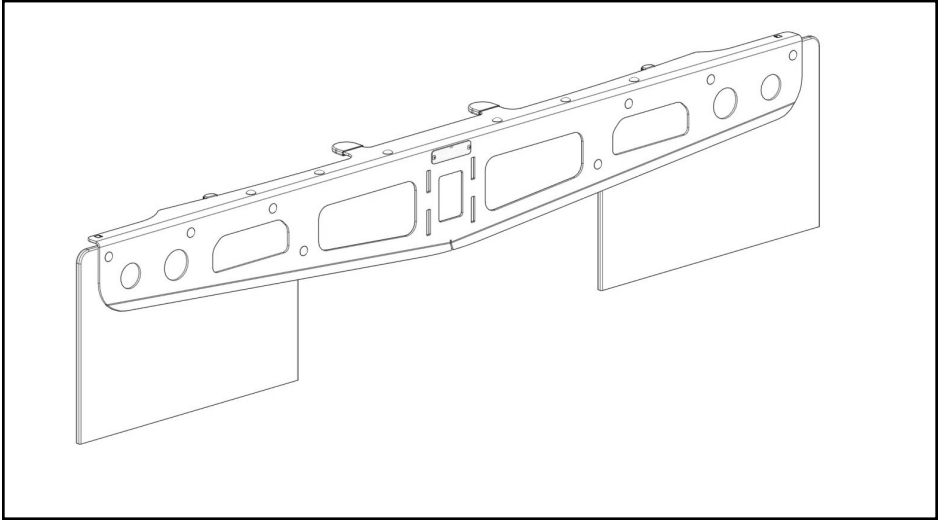

## 2019-ON CHEVY/GMC 1500 DUAL EXHAUST

Read and follow these special instructions along with the standard instructions carefully before installing or using these mud flaps.

**NOTICE TO INSTALLER:** Even if familiar with product, read special instructions prior to installation as improvements may be made without notice. Always handle components with care. When done, these special instructions must be given to the consumer.

**NOTICE TO CONSUMER:** Before using this product, read special instructions. Save these special instructions for future reference.

**IMPORTANT:** Use these special instructions with dual exhaust vehicles only.

# PREPARATION

## TOOLS NEEDED

- Protective eyewear
- Utility knife

**NOTE:** Hardware appearance may vary.

## SAFETY INFORMATION

- Always exercise caution when using a utility knife.
- Always cut away from yourself and other people.

**▲ WARNING:** Before installing mud flaps on dual exhaust vehicles ensure perforated regions are cut out, otherwise exhaust may cause damage to mud flaps or vehicle.

## 1: CUTTING PERFORATIONS

A. Before installing mud flaps to frame, cut out the perforated region in each mud flap.

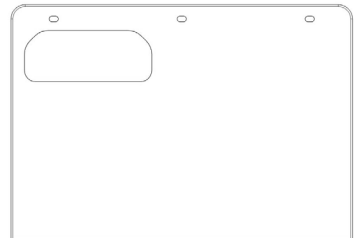
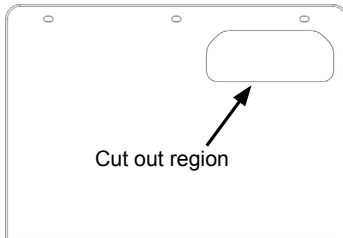
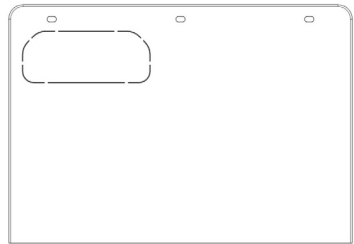
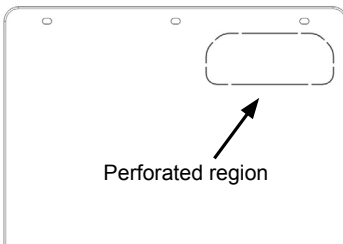

## 2: INSTALLING HEAT SHIELD

A. Heat Shield installs between mud flaps and frame on both sides with existing hardware.

**NOTE:** Heat Shield will protrude through mud flaps.

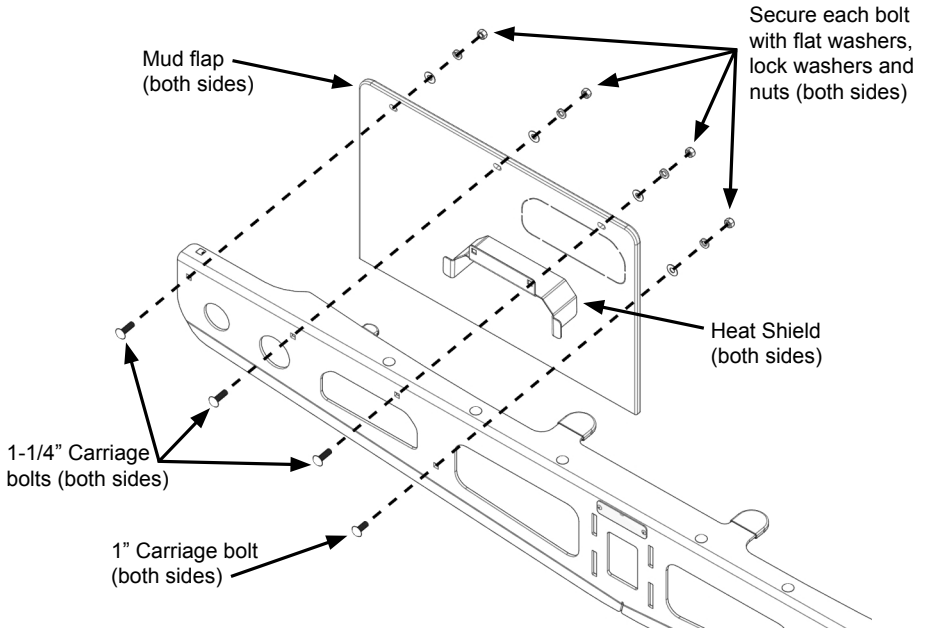

B. For attaching mud flaps to frame, refer to standard instructions.

**IMPORTANT:** When installing mud flaps to frame, ensure mud flap cut out and Heat Shield aligns with exhaust cut out in frame.

